



SUBMERSIBLE UTILITY PUMPS

PRODUCT FEATURES

- PUMP HOUSING:** One piece, flame retardant, corrosion resistant polymer. Includes handle and anti-air lock weep hole. Compartmentalized cord socket prevents water infiltration into the motor cavity.
- CORD SET:** SJTW, with ground, UL/CSA approved. Replaceable plug-in type with strain relief and 304 S.S. hold down clamp. 9 foot cord standard or 20 foot optional.
- MOTOR:** Oil free, low amp draw permanent split capacitor motor. Copper wound stator with 304 S.S. shaft and double ball bearings. On winding overload protection. 115 Volt, single phase, 60 Hz.
- MOTOR TO PUMP FLANGE:** Coated aluminum flange houses motor and dissipates motor heat.
- SHAFT SEAL:** Dual shaft seals, lip seal and mechanical face seal for double protection from water infiltration.
- GASKETS:** Heavy Buna N rubber gaskets seal the pump hydraulically and mechanically.
- IMPELLER:** Positive "D" drive thermoplastic impeller secured with 304 S.S. self-tightening, left handed nut to the motor shaft.
- BASE/VOLUTE:** Heavy wall polymer draws water down to 1/8" on 1/6 HP and 1/4HP pumps.
- OTHER:** 302 S.S. hardware.
- APPLICATIONS:** Dewatering and water transfer
Intermittent duty
Liquid temperature, up to 120°F.; 50°C.



1/6 HP

UTFAL w/9' cord
UTFAL20 w/20' cord



1/4 HP

2STFAL w/9' cord
2STFAL20 w/20' cord

DIMENSIONS

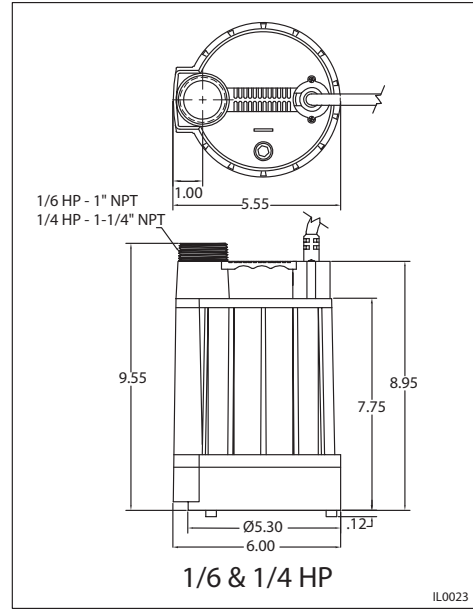

PERFORMANCE AND SPECIFICATIONS

MODEL NO.	HP	S.F. AMPS	GPM OF WATER @ TOTAL FT. OF HEAD USING MAX. DIAMETER PIPE					SHUT-OFF FEET	DISCH. NPT	CORD LENGTH
			5 Ft.	10 Ft.	15 Ft.	20 Ft.	30 Ft.			
UTFAL UTFAL20	1/6	1.5	15	11	6	0	0	19	1"	9 Ft. 20 Ft.
2STFAL 2STFAL20	1/4	2.2	30	22	12	0	0	20	1-1/4"	9 Ft. 20 Ft.

PERFORMANCE CURVES

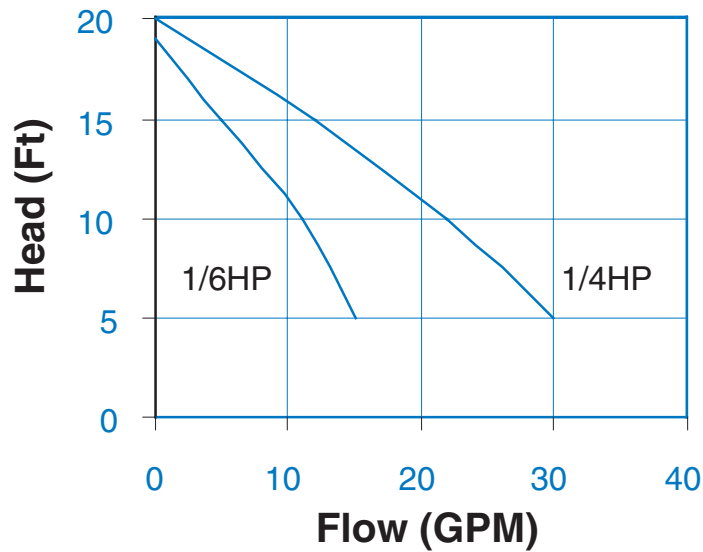

IL0021