



# UNITED BRASS WORKS, INC.

714 S. Main St., Randleman, NC 27317

Tel: 800-334-3035 Fax: 800-498-4696 www.ubw.com



## Model 126S Angle Valve

Soft Disc

200 WOG @ 180 ° Max

100% Pressure Tested

Threaded Ends

Rising Stem • Integral Seat

Swivel Disc Holder

MATERIAL LIST		
NO.	DESCRIPTION	MATERIAL
1	Hex Nut	Steel
2	Hand Wheel	Aluminum
3	Packing Nut	Brass
4	Packing	Graphite Non-Asb.
5	Bonnet (1/4" - 1") Bonnet (1 1/4" - 2")	Brass Bronze
6	Stem & Disc Holder	Brass
7	Disc	Buna N
8	Body	Bronze

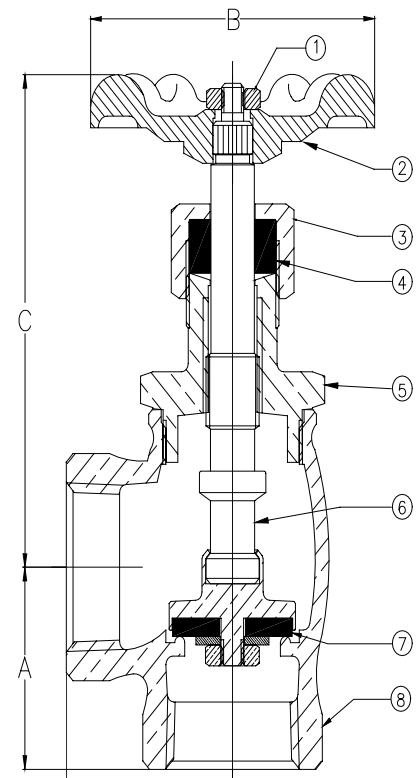

Size	1/4"	3/8"	1/2"	3/4"	1"	1 1/4"	1 1/2"	2"
A	0.84	0.94	1.03	1.22	1.47	1.75	2.00	2.34
B	1.75	1.75	2.03	2.38	2.75	3.00	3.72	3.72
C (closed)	2.63	3.00	3.13	3.25	4.38	4.50	5.25	5.63
Ship Wt. (lbs.)	0.44	0.56	0.69	0.94	1.76	2.50	3.26	5.32
Qty. Unit Pack	12	12	12	6	6	4	2	2
Qty. Per Case	60	60	72	60	36	24	12	12



# UNITED BRASS WORKS, INC.

714 S. Main St., Randleman, NC 27317

Tel: 800-334-3035 Fax: 800-498-4696 www.ubw.com



## Model 176PA Angle Valve

200 WOG @ 180 ° Max

100% Pressure Tested

Threaded Ends

Rising Stem • Integral Seat

Swivel Disc Holder

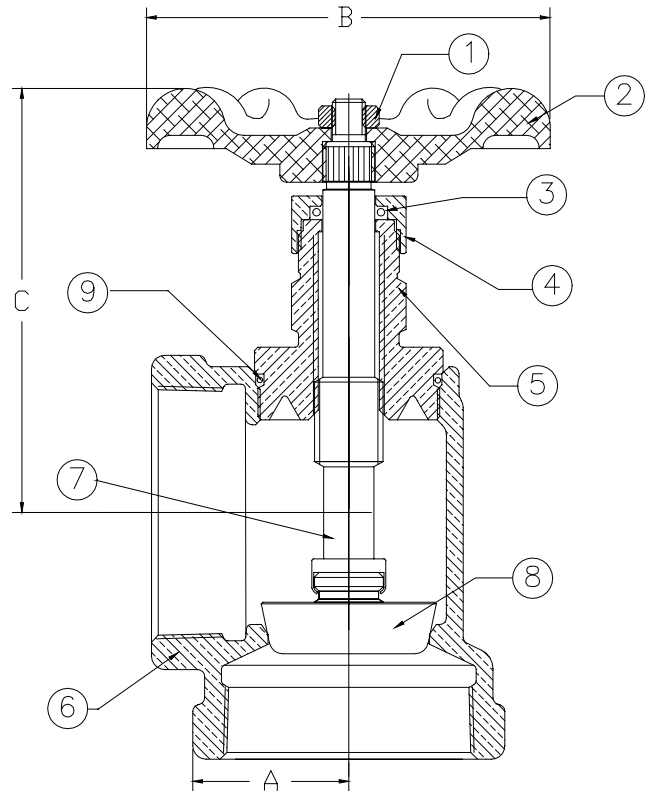

MATERIAL LIST		
NO.	DESCRIPTION	MATERIAL
1	Jam Nut	Steel
2	Handwheel	Aluminum
3	Stem O-Ring	Buna-N
4	O-Ring Nut	Brass
5	Bonnet	Brass
6	Body	Bronze
7	Stem	Brass
8	Disc	Acetron GP
9	Bonnet O-Ring	Buna-N

Size	A	B	C (Open)	C (Closed)	Ship Wgt. (lbs)	Qty. Unit Pack	Qty. Per Case
2"	2.30	3.75	5.25	3.90	2.9	2	12



**UNITED BRASS WORKS, INC.**

714 S. Main St., Randleman, NC 27317

Tel: 800-334-3035 Fax: 800-498-4696 www.ubw.com



## Model 126SUL Angle Valve Soft Disc



UL Listed for Fire Sprinkler Service at 250 WOG

200 WOG @ 180 ° Max

100% Pressure Tested

Threaded Ends

Rising Stem • Integral Seat

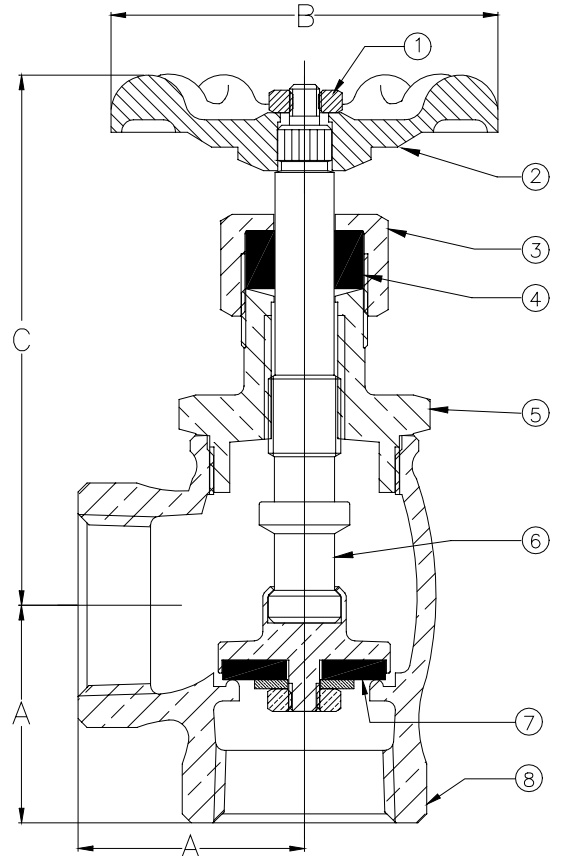

### MATERIAL LIST

NO.	DESCRIPTION	MATERIAL
1	Hex Nut	Steel
2	Hand Wheel	Aluminum
3	Packing Nut	Brass
4	Packing	Graphite Non-Asbestos
5	Bonnet (1/2" – 1") Bonnet (1 1/4" – 2")	Brass Bronze
6	Stem & Seat Assembly	Brass
7	Disc	Buna N
8	Body	Bronze

Size	1/2"	3/4"	1"	1 1/4"	1 1/2"	2"
A	1.03	1.22	1.47	1.75	2.00	2.34
B	2.03	2.38	2.75	3.00	3.72	3.72
C (closed)	3.13	3.25	4.38	4.50	5.25	5.63
Ship Wt. (lbs.)	0.69	0.94	1.76	2.50	3.26	5.32
Qty. Unit Pack	12	6	6	4	2	2
Qty. Per Case	72	60	36	24	12	12