



UNITED BRASS WORKS, INC.
 714 S. Main St., Randleman, NC 27317
 Tel: 800-334-3035 Fax: 800-498-4696 www.ubw.com



Model 79 Needle Valve

200WSP @ 406° Max
400 WOG
100% Pressure Tested
Threaded Ends
Rising Stem

MATERIAL LIST

NO.	DESCRIPTION	MATERIAL
1	Hex Head Screw	Steel
2	Hand Wheel	Aluminum
3	Stem	Brass
4	Packing	NAFG
5	Packing Nut	Brass
6	Bonnet	Brass
7	Body	Bronze

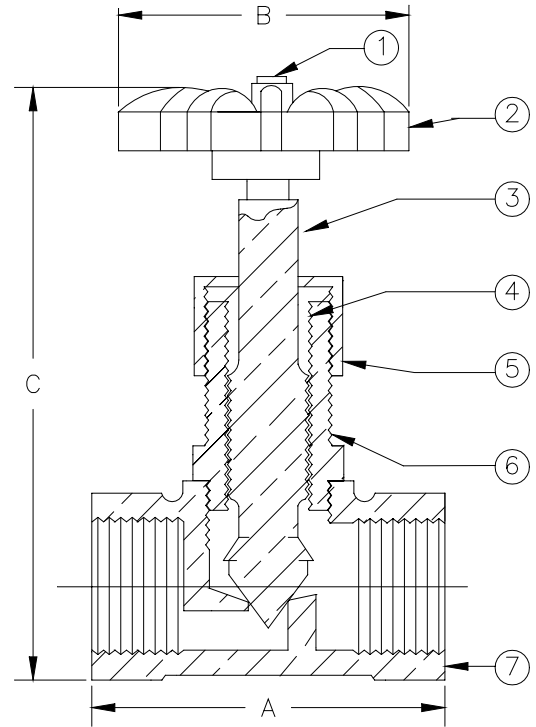

	1/8"	1/4"	3/8"	1/2"	3/4"
A	1.25	1.50	1.81	2.06	2.31
B	1.75	1.75	2.13	2.13	2.13
C Closed	2.25	2.25	2.63	2.88	3.75
C Open	2.38	2.38	2.75	3.13	4.00
Ship Wgt. (lbs.)	0.20	0.25	0.38	0.72	1.12
Qty. Per Ctn.	12	12	12	12	6



UNITED BRASS WORKS, INC.
 714 S. Main St., Randleman, NC 27317
 Tel: 800-334-3035 Fax: 800-498-4696 www.ubw.com



Model 77 Needle Valve

200WSP @ 406° Max

400 WOG

100% Pressure Tested

Threaded Ends

Rising Stem

MATERIAL LIST

NO.	DESCRIPTION	MATERIAL
1	Jam Nut	Steel
2	Hand Wheel	Aluminum
3	Stem	Brass
4	Packing	NAFG
5	Packing Nut	Brass
6	Bonnet	Brass
7	Body	Bronze

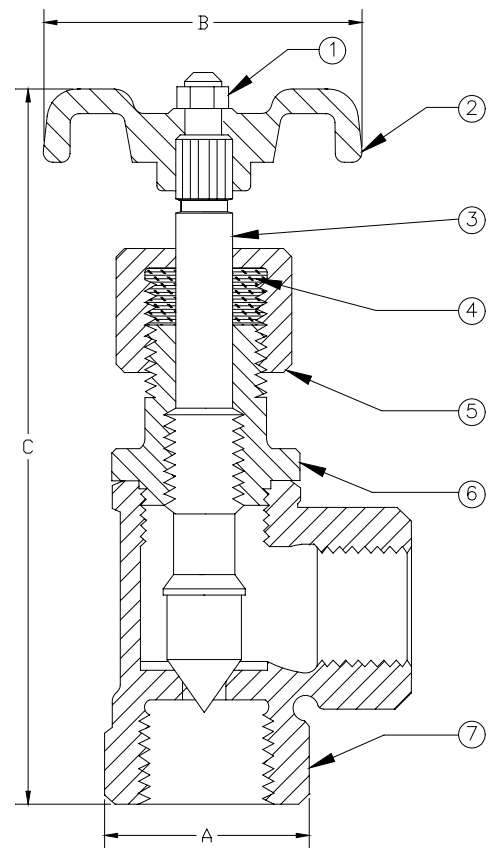

Size	1/8"	1/4"	3/8"	1/2"	3/4"
	0.63	1.19	.088	1.06	1.25
B	1.75	1.75	2.13	2.13	2.13
C Closed	2.25	2.25	2.63	2.88	3.75
C Open	2.38	2.75	2.75	3.13	4.00
Ship Wgt. (lbs.)	0.20	0.25	0.38	0.72	1.12
Qty. Per Ctn.	12	12	12	12	6



UNITED BRASS WORKS, INC.
 714 S. Main St., Randleman, NC 27317
 Tel: 800-334-3035 Fax: 800-498-4696 www.ubw.com



Model 78 Needle Valve

250 WOG @ 180 ° Max
100% Pressure Tested
Threaded Ends
Rising Stem

** Extra Heavy Duty Construction **

MATERIAL LIST

NO.	DESCRIPTION	MATERIAL
1	Hex Nut	Steel
2	Handle	Bronze
3	Stem	Brass
4	Packing Nut	Brass
5	Washer	Brass
6	Body	Bronze
7	Seat	PTFE
8	Packing	NAFG

Size	A	B	C Closed	C Open
A	2.25	2.31	2.69	2.94

