

## Condensate Units

For Condensate Units, Boiler Feed Units, Vacuum Heating Units, Pump and their accessories, contact Bell & Gossett Customer Service 847-966-3700

**H**offman condensate units are used to return condensate to the boiler. Applications include residential, commercial, institutional, and industrial

steam heating, and industrial processing; dry cleaning plants, chemical refineries, wood pulp paper processing, textile mills, and manufacturing facilities.

### Watchman® Series WC® & WCS® (Stock)

- For 6,000, 8,000 and 12,000 sq. ft. EDR systems\*
- Available with pumps in simplex or duplex design
- Low height NPT inlet for easy return line piping
- Separate NPT connections provide a secondary vent for safe operation
- NPT drain connection
- Double pole float switch - simplex models
- Mechanical alternator - duplex models
- Easy to install
- Easy to service with vertical pull out pumps
- 100% factory tested as a complete unit
- Series WC includes cast iron receiver with 20 year warranty against corrosion
- Series WCS includes steel receiver
- Optional equipment:
  - Inlet basket strainer
  - Y-strainer
  - Control panels for wall mounting
- Pump seal maximum temperature 225°F (107°C)
- 2' NPSH pumps capable of handing 209°F (98°C) condensate



**Series WC and WCS Simplex Design**



**Series WC Duplex Design**



**Series WCS Duplex Design**

\* For larger stock condensate units, contact your Hoffman representative.

**Dimensions, in.**

**Watchman® Series WC – 6 and 9 Gallon (23 and 34 Liter) Receiver**

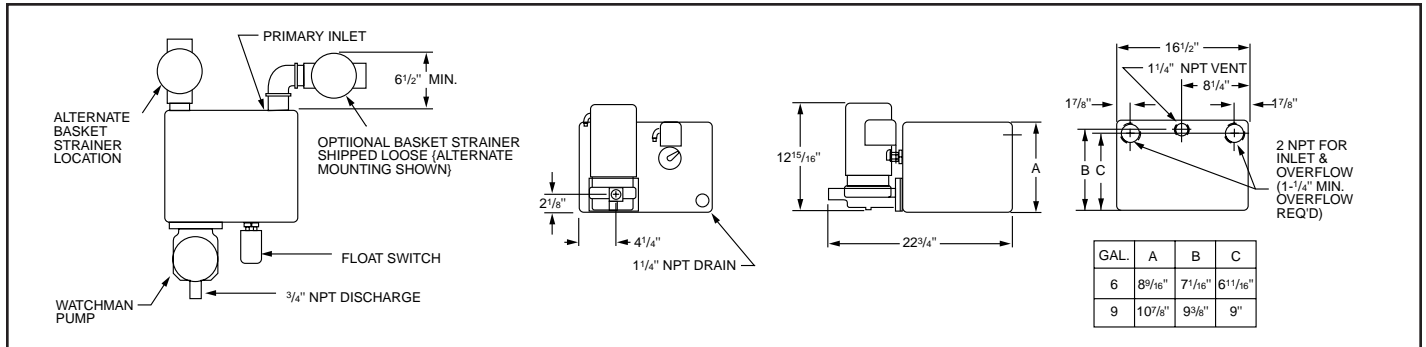

**Watchman® Series WC – 14 Gallon (53 Liter) Receiver**

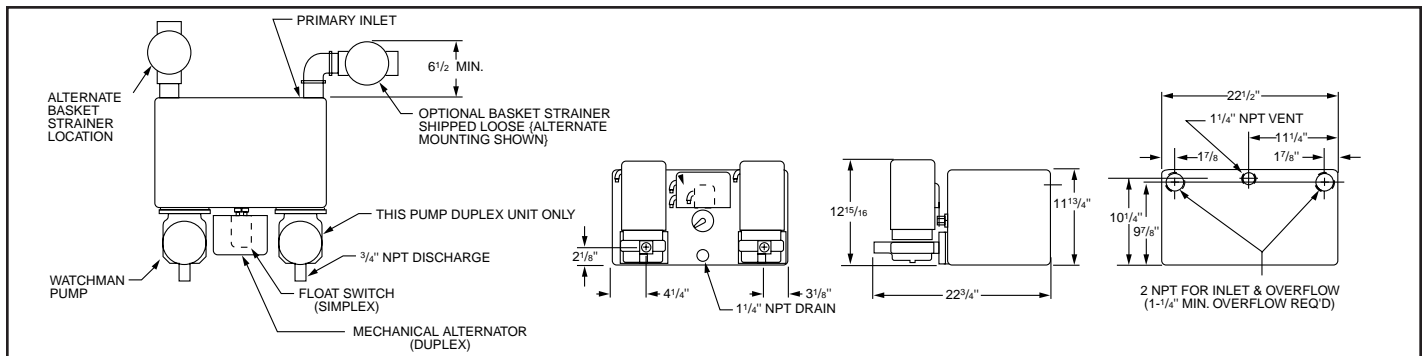

**Watchman® Series WCS – 6 and 9 Gallon (23 and 34 Liter) Receiver**

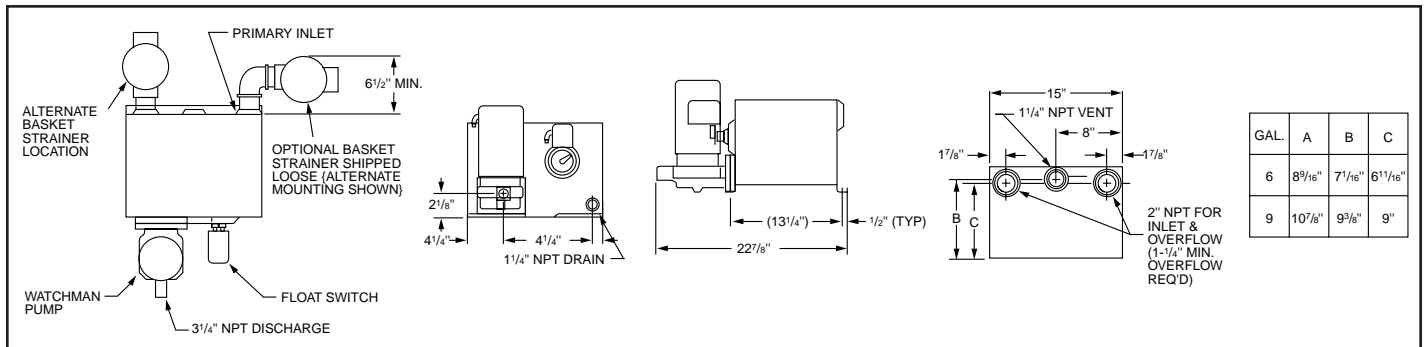

**Watchman® Series WCS – 14 Gallon (53 Liter) Receiver**

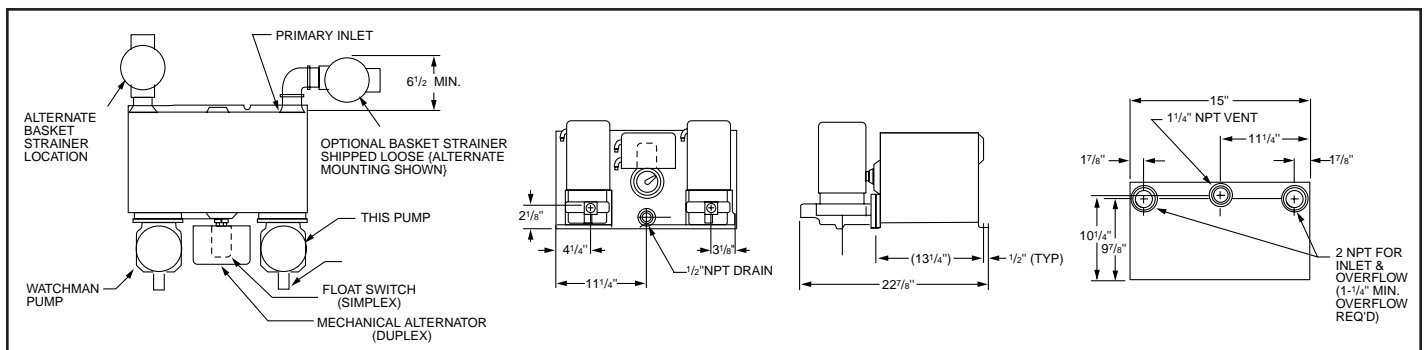

## How to Select

- Using the Ordering Information chart below, select unit based on:
  - System rating - EDR, Boiler HP or kW  
or
  - Pump GPM (LPS) and discharge pressure - 20 psig (138 kPa).
- Specify unit by Part number or Model Number when ordering.
- Specify Part Number of any desired optional equipment.

## Ordering Information

### Watchman® Series WC® Cast Iron Receiver Condensate Units

Model Number	Part Number	System Sq. Ft. EDR	Pump Style	Discharge Pressure		Pump Capacity		Receiver Capacity		Motor*		Accessories
				PSIG	(kPa)	GPM	(LPS)	Gal	(Liter)	HP	(kW)	
WC-6-20-B	160029	6,000	Simplex	22	(152)	9	(0.6)	6	(22.7)	1/3	(0.2)	Float Switch
WC-8-20-B	160030	8,000	Simplex	21	(145)	12	(0.8)	9	(34.1)	1/3	(0.2)	Float Switch
WC-12-20-B	160031	12,000	Simplex	20	(138)	18	(1.1)	14	(53.0)	1/3	(0.2)	Float Switch
WCD-12-20-B MA	160032	12,000	Duplex	20	(138)	18	(1.1)	14	(53.0)	1/3	(0.2)	Mechanical Alternator

\* 3500 RPM, 1 phase 115. (may be field converted to 230 V, 1 Phase).

### Watchman® Series WCS® Steel Receiver Condensate Units

Model Number	Part Number	System Sq. Ft. EDR	Pump Style	Discharge Pressure		Pump Capacity		Receiver Capacity		Motor*		Accessories
				PSIG	(kPa)	GPM	(LPS)	Gal	(Liter)	HP	(kW)	
WCS-6-20-B	160010	6,000	Simplex	22	(152)	9	(0.6)	6	(22.7)	1/3	(0.2)	Float Switch
WCS-8-20-B	160011	8,000	Simplex	21	(145)	12	(0.8)	9	(34.1)	1/3	(0.2)	Float Switch
WCS-12-20-B	160012	12,000	Simplex	20	(138)	18	(1.1)	14	(53.0)	1/3	(0.2)	Float Switch
WCSD-12-20-B MA	160013	12,000	Duplex	20	(138)	18	(1.1)	14	(53.0)	1/3	(0.2)	Mechanical Alternator

\* 3500 RPM, 1 phase 115. (may be field converted to 230 V, 1 Phase).