



UNITED BRASS WORKS, INC.
 714 S. Main St., Randleman, NC 27317
 Tel: 800-334-3035 Fax: 800-498-4696 www.ubw.com



Model 100 Check Valve
Union Swing Check

200WSP @ 406° Max
400 WOG
100% Pressure Tested
Threaded Ends • Metal Seat
Replaceable Insert

Replacement Insert – 100A

MATERIAL LIST

NO.	DESCRIPTION	MATERIAL
1	Body	Bronze
2	Coupling Nut (3/8" - 1/2") Coupling Nut (3/4" - 1 1/4")	Brass Bronze
3	Tail Piece	Bronze
4	Insert	See Spec 100A

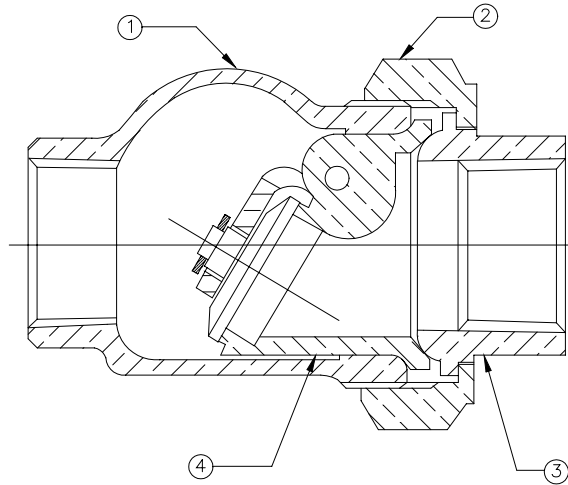

Size	3/8"	1/2"	3/4"	1"	1 1/4"
A	2.73	3.13	3.47	4.03	4.63
Ship Wgt. (lbs.)	0.63	0.95	1.50	2.22	3.38
Qty. Per Ctn.	12	12	12	6	6



UNITED BRASS WORKS, INC.
 714 S. Main St., Randleman, NC 27317
 Tel: 800-334-3035 Fax: 800-498-4696 www.ubw.com



Model 99 Swing Check Valve

125 WSP @ 350° Max
200 WOG

100% Pressure Tested • Threaded Ends
Metal Disc • Integral Seat

Install in horizontal position only.
Do not install laying on side. Keep seat clean.
Not Recommended for Pulsating or Vibrating Service!

MATERIAL LIST

NO.	DESCRIPTION	MATERIAL
1	Cap (1/4" - 1") Cap (1 1/4" - 2")	Brass Bronze
2	Washer	Brass
3	Body	Bronze
4	Disc	Brass
5	Hinge	Stainless Steel

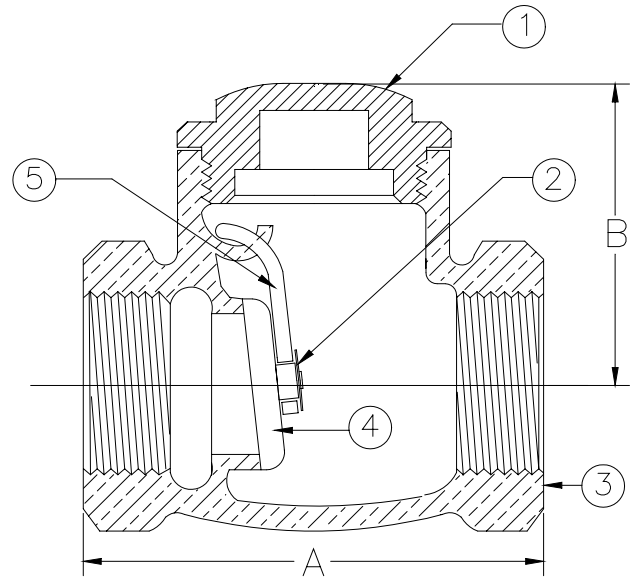

Size	1/4"	3/8"	1/2"	3/4"	1"	1 1/4"	1 1/2"	2"
A	1.89	1.89	2.14	2.51	3.03	3.45	3.81	4.44
B	1.22	1.22	1.28	1.53	1.74	2.20	2.20	2.86
Ship Wgt. (lbs.)	0.45	0.45	0.58	0.81	1.62	1.81	2.41	3.42
Qty. Unit Pack	12	12	12	12	6	6	4	2
Qty. Per Case	60	60	60	60	30	18	12	6



UNITED BRASS WORKS, INC.
 714 S. Main St., Randleman, NC 27317
 Tel: 800-334-3035 Fax: 800-498-4696 www.ubw.com



Model 99T Swing Check Valve

125WSP @ 350° Max
200 WOG
100% Pressure Tested
Threaded Ends • PTFE Disc
Integral Seal

Not recommended for pulsating or vibrating service.
Install in horizontal position only.
Do Not Install laying on side.
Keep seat clean.

MATERIAL LIST

NO.	DESCRIPTION	MATERIAL
1	Cap (1/4" - 1") Cap (1/4" - 2")	Brass Bronze
2	Washer	Brass
3	Body	Bronze
4	Disc	Brass
5	Hinge	Stainless Steel
6	Disc	PTFE

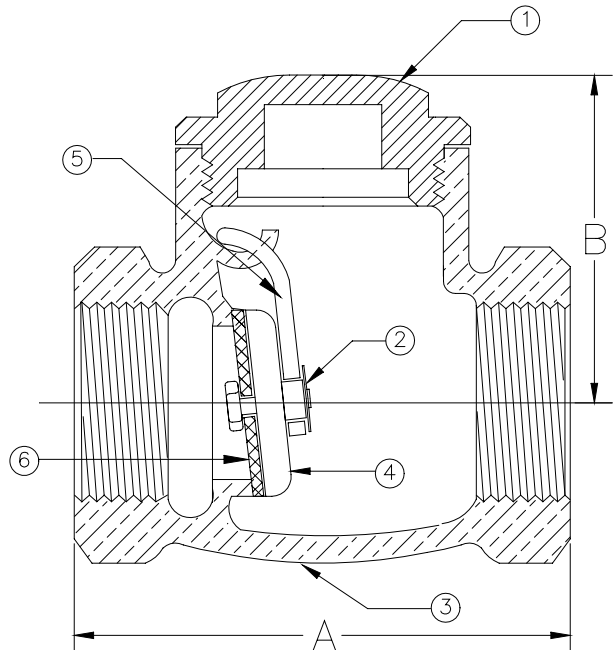

Size	1/4"	3/8"	1/2"	3/4"	1"	1 1/4"	1 1/2"	2"
A	1.89	1.89	2.14	2.51	3.03	3.45	3.81	4.44
B	1.22	1.22	1.28	1.53	1.74	2.20	2.20	2.86
Ship Wgt. (lbs.)	0.45	0.45	0.58	0.81	1.62	1.81	2.41	3.42
Qty. Unit Pack	12	12	12	12	6	6	4	2
Qty. Per Case	60	60	60	60	30	18	12	6



UNITED BRASS WORKS, INC.
 714 S. Main St., Randleman, NC 27317
 Tel: 800-334-3035 Fax: 800-498-4696 www.ubw.com



Model 99S Swing Check Valve

200 WOG @ 180 ° Max
100% Pressure Tested • Integral Seat
Threaded Ends • Soft Disc

Not recommended for pulsating or vibrating service.
Install in horizontal position only.
Do Not Install laying on side.
Keep seat clean.

MATERIAL LIST

NO.	DESCRIPTION	MATERIAL
1	Cap (1/4" - 1") Cap (1 1/4" - 2")	Brass Bronze
2	Washer	Brass
3	Body	Bronze
4	Disc	Brass
5	Hinge	Stainless Steel
6	Disc	Buna-N

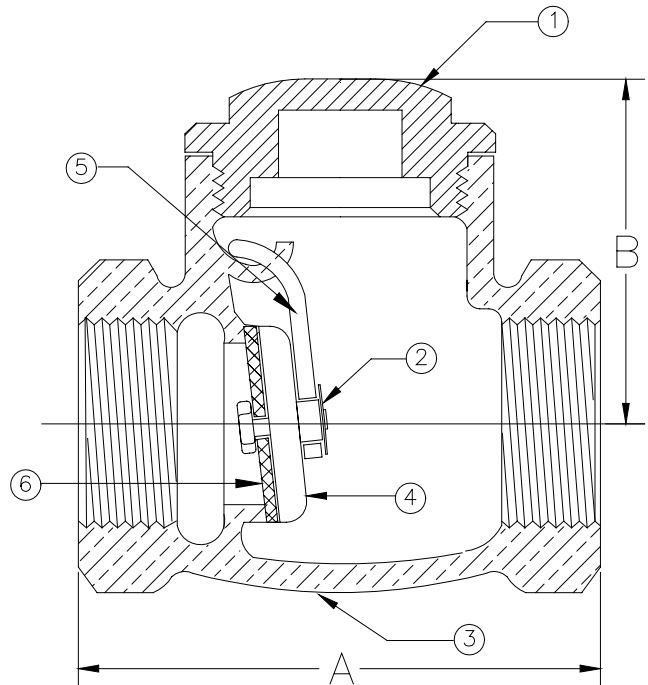

Size	1/4"	3/8"	1/2"	3/4"	1"	1 1/4"	1 1/2"	2"
A	1.89	1.89	2.14	2.51	3.03	3.45	3.81	4.44
B	1.22	1.22	1.28	1.53	1.74	2.20	2.20	2.86
Ship Wgt. (lbs.)	0.45	0.45	0.58	0.81	1.62	1.81	2.41	3.42
Qty. Unit Pack	12	12	12	12	6	6	4	2
Qty. Per Case	60	60	60	60	30	18	12	6



UNITED BRASS WORKS, INC.
 714 S. Main St., Randleman, NC 27317
 Tel: 800-334-3035 Fax: 800-498-4696 www.ubw.com



Model 62 Swing Check Valve
Complies with MSS-SP-80-97

200WSP @ 406° Max
400 WOG
100% Pressure Tested
Threaded Ends

*Install in horizontal position with cap in upright position.
 Not recommended for pulsating or vibrating service.*

When used on Boiler feed line it is recommended that a #50T spring loaded check valve be used in conjunction with #62 with the #62 located nearest to the boiler and the #50T located nearest to the pump.

MATERIAL LIST

NO.	DESCRIPTION	MATERIAL
1	Cap (1/4" - 3/4") Cap (1" - 3")	Brass Bronze
2	Hinge Pin	Brass
3	Hinge	Stainless Steel
4	Body	Bronze
5	Disc	Bronze
6	Disc Nut	Brass

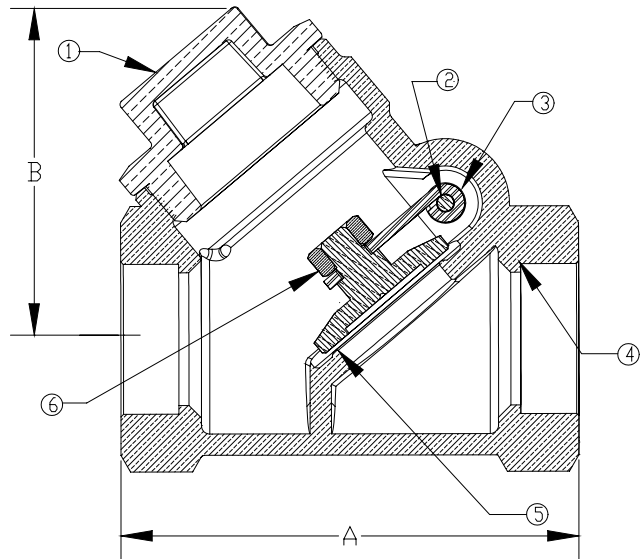

Size	1/4"	3/8"	1/2"	3/4"	1"	1 1/4"	1 1/2"	2"	3"
A	2.38	2.53	2.66	3.09	3.53	5.13	5.13	5.56	9.13
B	1.53	1.53	1.53	1.88	2.09	3.63	3.63	4.56	5.58
Ship Wgt. (lbs.)	0.75	0.81	0.76	1.19	1.73	5.75	5.75	10.00	29.00
Qty. Per Ctn.	12	12	12	12	6	2	2	1	1



UNITED BRASS WORKS, INC.
 714 S. Main St., Randleman, NC 27317
 Tel: 800-334-3035 Fax: 800-498-4696 www.ubw.com



Model 62T Swing Check Valve

Complies with MSS-SP-80-97

200WSP @ 406° Max
400 WOG
100% Pressure Tested
Threaded Ends
PTFE Disc

*Install in horizontal position with cap in upright position.
 Not recommended for pulsating or vibrating service.*

MATERIAL LIST

NO.	DESCRIPTION	MATERIAL
1	Cap (1/4" - 3/4") Cap (1" - 3")	Brass Bronze
2	Hinge Pin	Brass
3	Hinge	Stainless steel
4	Disc	Bronze
5	Disc	PTFE
6	Washer	Brass
7	Screw	Brass
8	Body	Bronze
9	Disc Nut	Brass

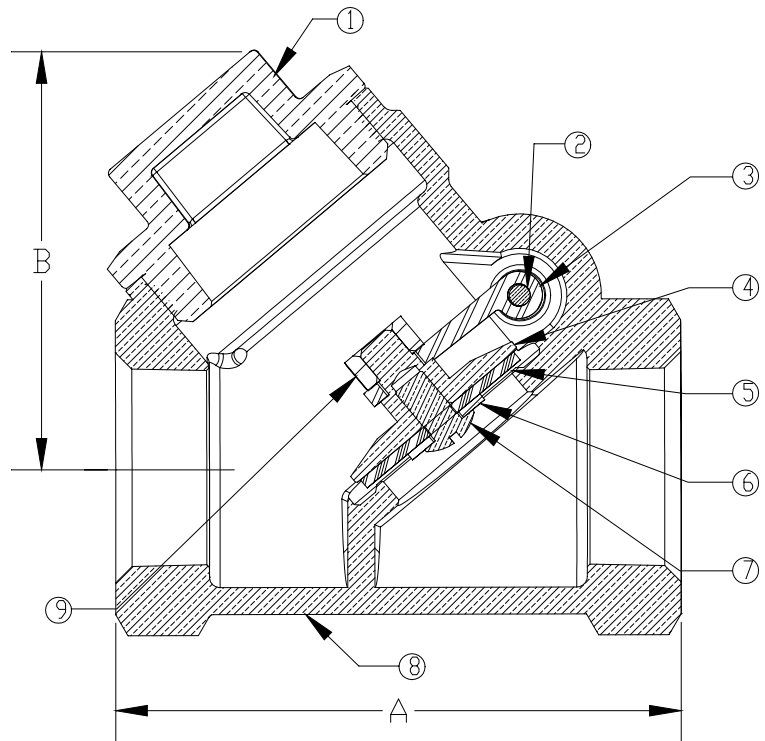

Size	1/4"	3/8"	1/2"	3/4"	1"	1 1/4"	1 1/2"	2"	3"
A	3.38	2.53	2.66	3.09	3.53	5.13	5.13	5.56	9.13
B	1.51	1.53	1.53	1.88	2.09	3.63	3.63	4.56	5.58
Ship Wgt. (lbs.)	0.75	0.81	0.76	1.19	1.73	5.75	5.75	10.00	29.00
Qty. Per Ctn.	12	12	12	12	6	2	2	1	1



UNITED BRASS WORKS, INC.
 714 S. Main St., Randleman, NC 27317
 Tel: 800-334-3035 Fax: 800-498-4696 www.ubw.com



Model 62S Swing Check Valve

Complies with MSS-SP-80-97

400 WOG @ 180 ° Max
100% Pressure Tested
Threaded Ends

*Install in horizontal position with cap in upright position.
 Not recommended for pulsating or vibrating service.*

MATERIAL LIST		
NO.	DESCRIPTION	MATERIAL
1	Cap (1/4" - 3/4") Cap (1" - 3")	Brass Bronze
2	Disc Nut	Brass
3	Hinge	Stainless Steel
4	Hinge Pin	Brass
5	Disc Holder	Brass
6	Disc	Buna-N
7	Washer	Brass
8	Screw	Brass
9	Body	Bronze

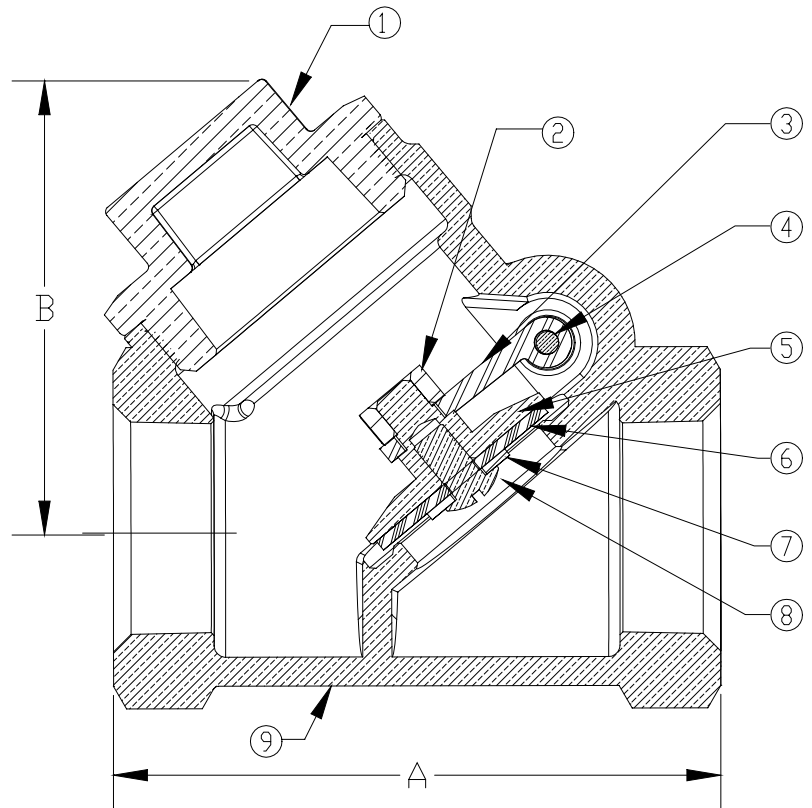

Size	1/4"	3/8"	1/2"	3/4"	1"	1 1/4"	1 1/2"	2"	3"
A	3.38	2.53	2.66	3.09	3.53	5.13	5.13	5.56	9.13
B	1.53	1.53	1.53	1.88	2.09	3.63	3.63	4.56	5.88
Ship Wgt. (lbs.)	0.75	0.81	0.76	1.19	1.73	5.75	5.75	10.00	29.00
Qty. Per Ctn.	12	12	12	12	6	2	2	1	1



UNITED BRASS WORKS, INC.
 714 S. Main St., Randleman, NC 27317
 Tel: 800-334-3035 Fax: 800-498-4696 www.ubw.com



Model 63 Swing Check Valve

Complies with MSS-SP-80-97

300 WSP
600 WOG
100% Pressure Tested
Threaded Ends

*Install in horizontal position with cap in upright position.
 Not recommended for pulsating or vibrating service.*

MATERIAL LIST

NO.	DESCRIPTION	MATERIAL
1	Cap (1/2 - 3/4") Cap (1" - 3")	Brass Bronze
2	Disc Nut	Bronze
3	Hinge Pin	Brass
4	Body	Bronze
5	Hinge	Stainless Steel
6	Disc	Bronze

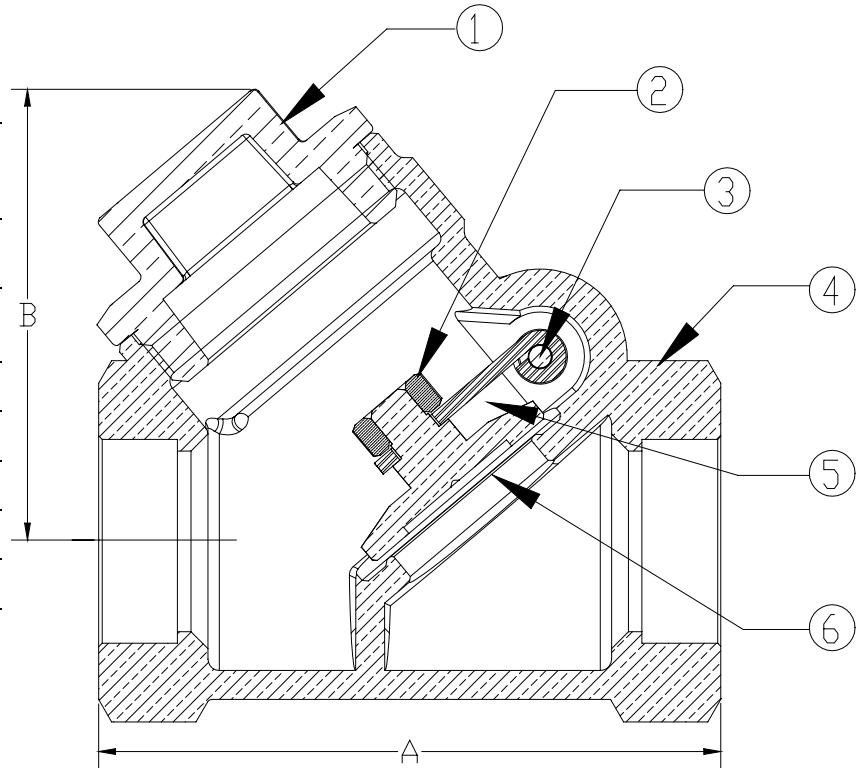

Size	1/2"	3/4"	1"	1 1/4"	1 1/2"	2"	3"
A	2.66	3.09	3.53	5.13	5.13	5.56	9.13
B	1.53	1.88	2.09	3.63	3.63	4.56	5.58
Ship Wgt. (lbs.)	0.76	1.19	1.73	5.75	5.75	10.00	29.00
Qty. Per Ctn.	12	12	6	2	2	1	1