

Product information presented here reflects conditions at time of publication. Consult factory regarding discrepancies or inconsistencies.

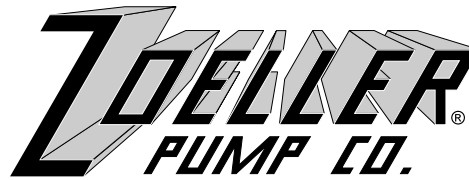

MAIL TO: P.O. BOX 16347 • Louisville, KY 40256-0347
 SHIP TO: 3649 Cane Run Road • Louisville, KY 40211-1961
 (502) 778-2731 • 1 (800) 928-PUMP • FAX (502) 774-3624

visit our web site:
<http://www.zoeller.com>

SPECIFICATIONS

EFFLUENT/SUMP DUPLEX SYSTEM

ZOELLER SUBMERSIBLE DEWATERING OR EFFLUENT PUMPS

SEAL	SOLIDS	DISCHARGE	MATERIAL	MODELS							
Single	1/2"	1½" NPT	Cast Iron	53	57	98	140				
Single	1/2"	1½" NPT	Cast Bronze	55	59						
Single	5/8"	1½" NPT	Cast Iron	137	191						
Single	5/8"	1½" NPT	Cast Bronze	139							
Single	3/4"	1½" NPT	Cast Iron	152	153						
Single	3/4"	1½", 2", or 3 NPT	Cast Iron	161	163	165	185	186	188	189	
Double	1/2"	1½"	Cast Iron	4140							
Double	3/4"	1½", 2", or 3 NPT	Cast Iron	4161	4163	4165	4185	4186	4188	4189	

DUPLEX SYSTEM

Furnish two Zoeller nonautomatic submersible pumps, Model _____ with an _____ Electrical or _____ Mechanical Alternating System. Pumps shall have a capacity of _____ GPM against a Total Dynamic Head of _____ feet. Motor specification: _____ voltage, _____ cycles, _____ phase, _____ HP. Discharge to be _____ 1½" NPT. Optional discharge _____ 2" NPT or _____ 3" NPT (161/4161 thru 189/4189). Cord length to be _____ feet. Pumps will pass _____ 1/2 inch solids (53,55,57,59, 98, 140/4140 Series) or _____ 5/8 inch solids (137/139, 191) or _____ 3/4 inch solids (152, 153, 161/4161, 163/4163, 165/4165, 185/4185, 186/4186, 188/4188 & 189/4189 Series.) Pumps shall be _____ UL listed, _____ CSA approved, _____ SSPMA certified, _____ State of Wisc. approved, _____ other (Specify _____).

SINGLE PHASE PUMPS

GENERAL

Pump motor shall be hermetically sealed, submersible type, operating in a high quality dielectric oil for cooling the windings and for lubrication of the motor bearings and ceramic-carbon shaft seal. Single phase motor shall have internal automatically resetting, thermal overload protection. Construction shall be of _____ Cast Iron with 100% baked-on powder coated epoxy finish for corrosion resistance and longer casting durability or _____ Cast Bronze. All fasteners and external metal parts shall be of stainless steel. Impeller shall be of vortex non-clog design. (Addition noted below.)

Check Applicable Series:

- _____ 53 (Cast Iron) _____ 55 (Cast Bronze) Series Pump shall have a shaded pole motor. Impeller, with metal insert, and base shall be of glass reinforced molded material. Switch case shall be of cast or molded material. Guard and handle shall be of stainless steel.
- _____ 57 (Cast Iron) _____ 59 (Cast Bronze) Series Pump shall have a shaded pole motor. Guard and handle shall be of stainless steel.
- _____ 98 (Cast Iron) Series- Pump shall have 1/2 HP PSC motor.
- _____ 137 (Cast Iron) _____ 139 (Cast Bronze) Series Pump shall have ½ HP split phase motor with current sensing, starting relay enclosed in switch housing.

- _____ 152 (.4 HP) _____ 153 (½ HP) series pump shall have a permanent split capacitor motor. The impeller shall be glass reinforced thermoplastic. Motor housing shall be cast iron.
- _____ 140 (Cast Iron) Series Pump shall have a 1 HP permanent split capacitor motor with capacitor in the switch housing attached to the pump. The impeller shall be cast bronze. Motor housing shall be cast iron. Discharge shall be a permanently affixed 1½" female NPT hub.
- _____ 4140 (Cast Iron) Series Pump with double carbon/ceramic shaft seals shall have a 1 HP permanent split capacitor motor with capacitor in the switch housing attached to the pump. The impeller shall be cast bronze. Motor housing shall be cast iron. Discharge shall be a permanently affixed 1½" female NPT hub. The lower seal cavity shall be oil-filled.
- _____ 161 (½ HP) _____ 163 (½ HP) _____ 165 (1 HP) Cast Iron Series- Pump shall have a permanent split capacitor motor with run capacitor enclosed in switch housing. Impeller shall be of cast bronze. Motor housing shall be finned for extra cooling capability.
- _____ 4161 (½ HP) _____ 4163 (½ HP) _____ 4165 (1 HP)

Cast iron series pump with double carbon/ceramic shaft seals shall have a permanent split capacitor motor with run capacitor enclosed in the switch housing. Impeller shall be cast bronze. Motor housing shall be finned for extra cooling capability. The lower seal cavity shall be oil-filled.

____ 185 (1 HP) ____ 186 (1½ HP) ____ 188 (1½ HP)
____ 189 (2 HP) ____ 191 (2 HP) Cast Iron Series-Pump shall have a permanent split capacitor motor with run capacitor enclosed in switch housing. Impeller shall be of cast bronze. Motor housing shall be finned for extra cooling capability.

____ 4185 (1 HP) ____ 4186 (1½ HP) ____ 4188 (1½ HP)
____ 4189 (2 HP) Cast iron series pump with double carbon/ceramic shaft seals shall have a permanent split capacitor motor with run capacitor enclosed in the switch housing. Impeller shall be cast bronze and pump housing shall be epoxy coated. Motor housing shall be finned for extra cooling capability. The lower seal cavity shall be oil-filled.

____ 191 (2 HP) Cast iron series pump with carbon/ceramic shaft seals shall have a permanent split capacitor motor with run capacitor enclosed in the switch housing. Impeller shall be cast bronze. Impeller shall be of a closed type construction. Motor housing shall be finned for extra cooling capability. The lower seal cavity shall be oil-filled.

THREE PHASE PUMPS

Pump motor shall be hermetically sealed, submersible type, operating in a high quality dielectric oil for cooling the windings and for lubrication of the motor bearings and ceramic-carbon shaft seal. Pump motor shall have external magnetic contactor and overload protection. All fasteners and external metal parts shall be of stainless steel. Impeller shall be of vortex non-clog design.

(Addition noted below.)

____ 137 (Cast Iron) series ____ 139 (Cast Bronze) Series shall have a 4-pole squirrel cage induction motor.

____ 161 (½ HP) ____ 163 (½ HP) ____ 165 (1 HP) Cast Iron Series shall have a 2-pole squirrel cage induction motor. Impeller shall be of cast bronze. Motor housing shall be finned for extra cooling capability.

____ 4161 (½ HP) ____ 4163 (½ HP) ____ 4165 (1 HP) Cast iron series pump with double carbon/ceramic shaft seals shall have a 2-pole squirrel cage induction motor. Impeller shall be cast bronze. Motor housing shall be finned for extra cooling capability. The lower seal cavity shall be oil-filled.

____ 185 (1 HP) ____ 186 (1½ HP) ____ 188 (1½ HP)
____ 189 (2 HP) Cast Iron Series shall have a 2-pole squirrel cage induction motor. Impeller shall be of cast bronze. Motor housing shall be finned for extra cooling capability.

____ 4185 (1 HP) ____ 4186 (1½ HP) ____ 4188 (1½ HP)
____ 4189 (2 HP) Cast iron series pump with double carbon/ceramic shaft seals shall have a 2-pole squirrel cage induction motor. Impeller shall be cast bronze. Motor housing shall be finned for extra

cooling capability. The lower seal cavity shall be oil-filled.

ALTERNATING SYSTEM ELECTRICAL ALTERNATING SYSTEM

Alternator - Single Phase

A Zoeller ____ Electrical Alternator Panel with three 10-0225 Control Switches shall be furnished. Panel shall be ____ UL Listed or ____ CSA approved and shall include an alternating circuit, separate contact relays, run lights, circuit breakers and H-O-A switches for each pump. Also included shall be a numbered terminal strip and a high water alarm and light. Overload protection shall be furnished in the pump motor. Panel shall have a NEMA ____ rating. Electrical components shall be sized for Zoeller model ____, ____ volt, ____ cycle, ____ phase, ____ HP pump, ____ FLA.

Alternator - Three Phase

A Zoeller ____ Electrical Alternator Panel with three 10-0225 Control Switches shall be furnished. Panel shall be ____ UL Listed or ____ CSA approved and shall include an alternating circuit, separate magnetic starters with overload protection, run lights, and H-O-A switches for each pump. The control panel shall include a transformer to reduce control voltage to 115 volts. Also included shall be a numbered terminal strip and a high water alarm and light. Panel shall have a NEMA 4X rating. Electrical components shall be sized for a Zoeller Model ____, ____ volt, ____ cycle, ____ phase, ____ HP pump, ____ FLA.

Variable Level Float Controls- Single Phase or Three Phase

Variable Level Float Controls shall provide automatic operation of pumps and alarm. Two controls shall close circuit for on/off operation at selected levels as required to rotate operation of pumps. The third variable level float shall close an override circuit to operate both pumps and to activate alarm. Control shall be omnidirectional, normally open and shall include a 15' SJOWA neoprene cord. All controls shall be fastened to variable level float mounting pipe with plastic tie mounting strap. The pipe, attached to the underside of the removable inspection plate on the basin cover, shall be furnished and installed by the contractor.

MECHANICAL ALTERNATING SYSTEM

Alternator - Single Phase

A Zoeller ____ 10-0072 or ____ 10-0075 (includes alarm switch) "M-Pak" Mechanical Alternator shall be supplied to control sump level. Alternator shall be UL listed and shall have double pole alternating switch with adjustable tension. Alternator shall provide on/off operation at selected levels and shall provide an override to operate both pumps in parallel when required. Alternator control shall be contained in a NEMA 1 enclosure and shall be fastened to and furnished with a separate cast iron stand. Stainless steel float shall be 7" diameter and mounted on a 6' brass rod. Rod shall be sealed in a gas tight neoprene convoluted tube seal where it passes through the cover mount stand. Four (4) adjustable stops shall be included. (Additions noted below.)

_____ 10-0075 "M-Pak" Mechanical Alternator shall provide an alarm switch to sound a _____ 10-0015 (115V), 10-0016 (230V), or a 10-0126 (115V) "A-Pak" alarm when activated. Included shall be six (6) inch steel alarm bell, which shall sound sixty-eight (68) decibels at a distance of ten (10) feet and a dual mount UL Listed transformer, which shall step down 115V or 230V 1 Ph line voltage to 8V. (Three phase mechanical alternating systems - Consult factory).

ACCESSORIES/MISCELLANEOUS UNICHECK

_____ 30-0200, (Clamp union valve) (1¼, 1½ inch) full flow check valve, rated at 4.3 psi pressure (10 feet TDH) at 130 deg. F. shall be furnished to fit 1¼ inch or 1½ inch ABS, PVC, CPVC, steel or copper piping. Unichек shall have valve body and seat of PVC plastic and shall be assembled with thru bolts. Gasket and flapper shall be neoprene with brass backing plates and stainless steel rivet. Unichек shall include two (2) neoprene unions and four (4) stainless steel clamps and fasteners.

_____ 30-0021, (Clamp union valve) (2 inch) full flow check valve, rated at 4.3 psi pressure (10 feet TDH) at 130 deg. F. shall be furnished to fit 2 inch ABS, PVC, CPVC, steel or copper piping. Unichек shall have valve body and seat of PVC plastic and shall be assembled with thru bolts. Gasket and flapper shall be neoprene with brass or stainless steel backing plates and stainless steel rivet. Unichек shall include two (2) neoprene unions and four (4) stainless steel clamps and fasteners.

_____ 30-0015, (Compression Union Valve) 1½ inch IPS full flow check valve shall be furnished to fit 1½ inch IPS pipe. Unichек body and compression and fittings shall be constructed of PVC. Flapper and end seals shall be Buna-N. Valve shall include no metallic parts. Pressure rated at 25 PSI (57 feet TDH) at 130 deg. F.

_____ 30-0152, (2 inch) cast iron full flow check valve with 2" female N.P.T. Rated at 50 PSI (115 feet TDH) at 130 deg. F. Neoprene polyester reinforced flapper with cast iron and brass backing plates and stainless steel fastener.

_____ 30-0160, (3 inch) cast iron full flow check valve with 3" female N.P.T. Rated at 50 PSI (115 feet TDH) at 130 deg. F. Neoprene polyester reinforced flapper with cast iron and brass backing plates and stainless steel fastener.

SUMP BASIN

A Zoeller IAMPO approved _____ polyethylene basin, .230 inch thick, .949 G/CC dense, or Zoeller _____ fiberglass basin, 3/16 inch thick, .058 pounds/cubic feet dense, _____ inches inside diameter by _____ inches deep shall be furnished. The basin shall include _____ four (4) inch cast iron caulk inlet hubs with anticorrosion coating. The centerline of the hub(s) shall be located nine (9) inches from the top of the basin. The basin shall also include a .125 inch thick steel sump cover. Cover shall have two (2) pump installation plates

and an inspection plate. Optional anti-flotation ring can also be provided. Also included shall be two (2) neoprene seals for pump cords, neoprene seal for vent and discharge flanges, foam cover seal and plated steel fasteners. Cover shall include a _____ inch vent and two (2) _____ inch discharge flanges with mounting hardware.

PIPING & POWER WIRING

All piping shall be rigid and permanent in nature and shall be furnished and installed by the contractor. A unichек shall be installed in the discharge pipe. A 3/16" vent hole shall be drilled in the discharge pipe below the check valve and pit cover to purge the system of trapped air. Power wiring shall be supplied by electrical contractor. Power wiring for pumping system and alarm system shall be connected to separate circuits.

EXTRA DUTY

Where conditions require, specify extra duty for adverse operating conditions.

HIGH TEMPERATURE PUMPS

For applications up to 200 deg. F. continuous operation, specify High Temperature Zoeller Pump Co. models. See literature on High Temperature pumps, FM0806 and FM0807, for additional information. For 200 deg. F. specification sheet, see FM0817.

PUMP DISCONNECTS AND RAIL SYSTEMS

Where conditions, due to safety, health and the economy of maintenance require pump disconnects or rail systems specify:

- _____ 39-0001, 1½" NPT Disconnect (Non-pump Supporting)
- _____ 39-0002, 2" Disconnect (Non-pump Supporting)
- _____ 39-0003, 1½" NPT Rail System (Non-pump Supporting)
- _____ 39-0004, 2" NPT Rail System (Non-pump Supporting)
- _____ 39-0085, 1½" NPT Galv. Ez Out (Pump Supporting)
- _____ 39-0086, 1½" NPT S.S. Ez Out (Pump Supporting)
- _____ 39-0083, 2" NPT Galv. Ez Out (Pump Supporting)
- _____ 39-0084, 2" NPT S.S. Ez Out (Pump Supporting)
- _____ 39-0074, 3" NPT Galv. Ez Out (Pump Supporting)
- _____ 39-0075, 3" NPT S.S. Ez Out (Pump Supporting)

Square Guide Rail Systems shall include single rigid stainless steel square rail design, red brass disconnect fitting, cast iron angle arm bracket and guide plates. _____ Galvanized or _____ stainless piping, PVC ball valve, cast iron check valve. Rail system shall be for a Zoeller Model _____ with a _____ inch discharge. Rail system will be for a _____ inch diameter basin.

EFFLUENT DUPLEX SYSTEM WITH MECHANICAL ALTERNATOR (SINGLE PHASE)

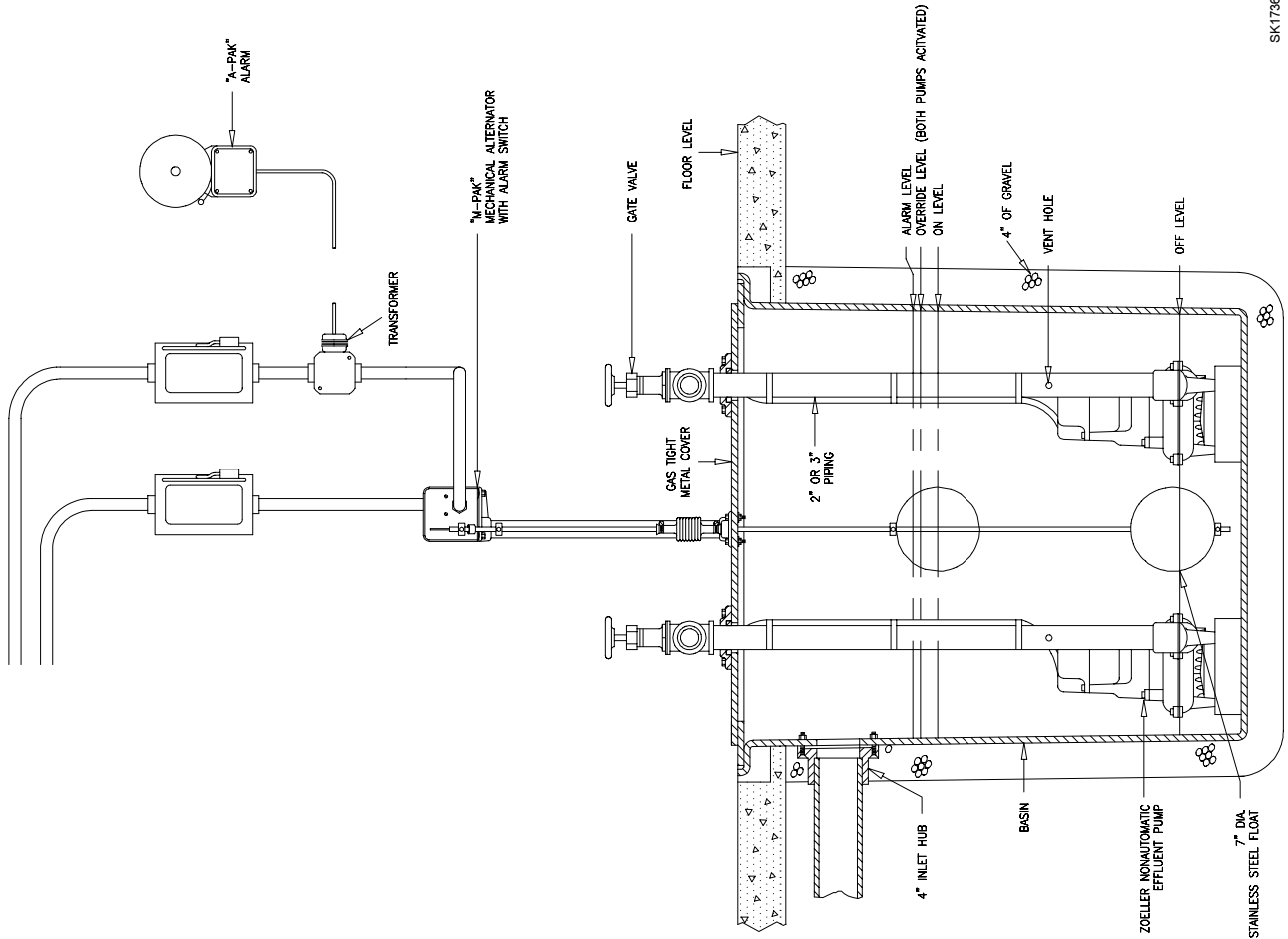

SK1736

EFFLUENT DUPLEX SYSTEM WITH MECHANICAL ALTERNATOR (SINGLE PHASE) TOP VIEW

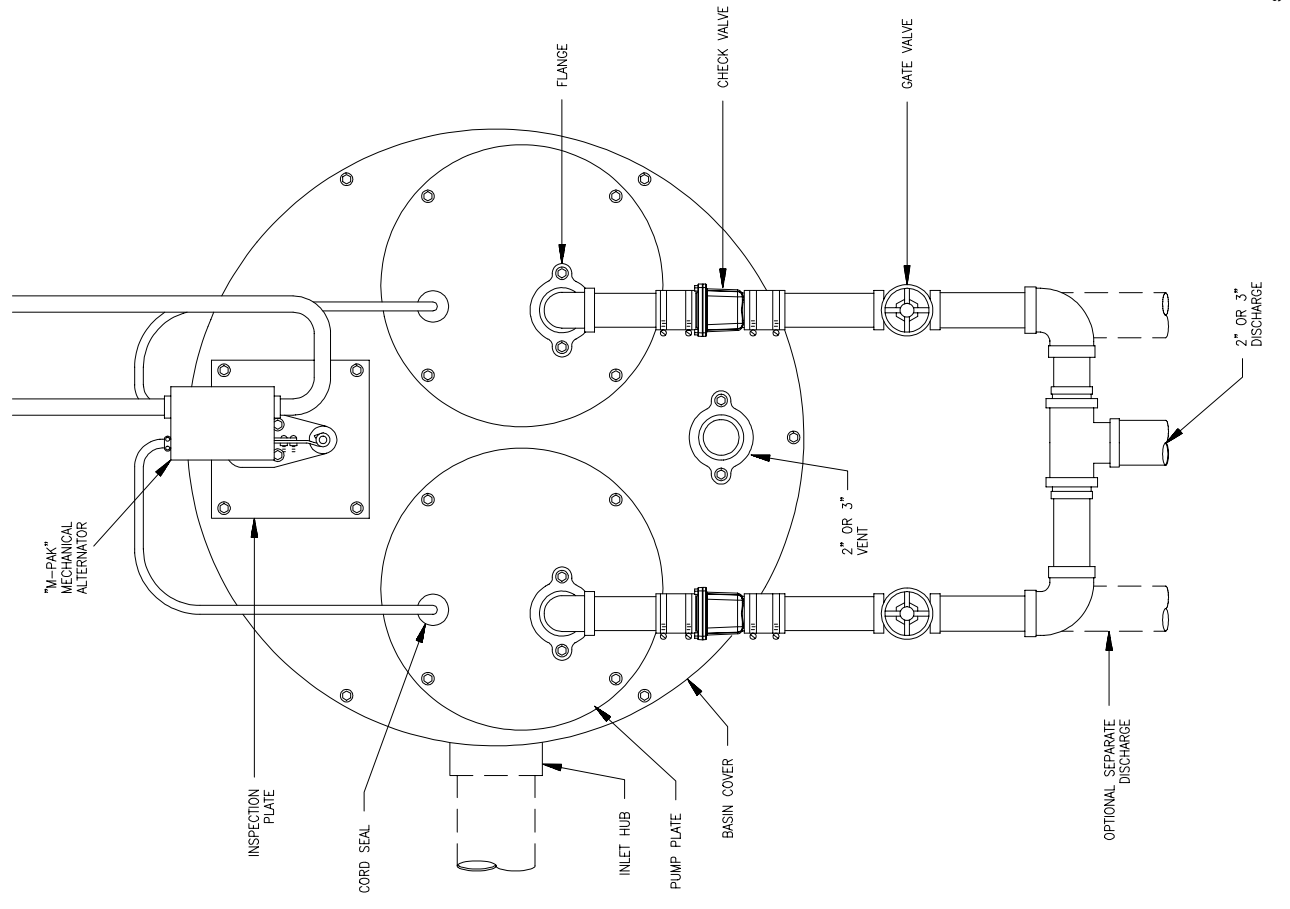

SK1483

**EFFLUENT DUPLEX ELECTRICAL ALTERNATING SYSTEM
1 OR 3 PHASE**

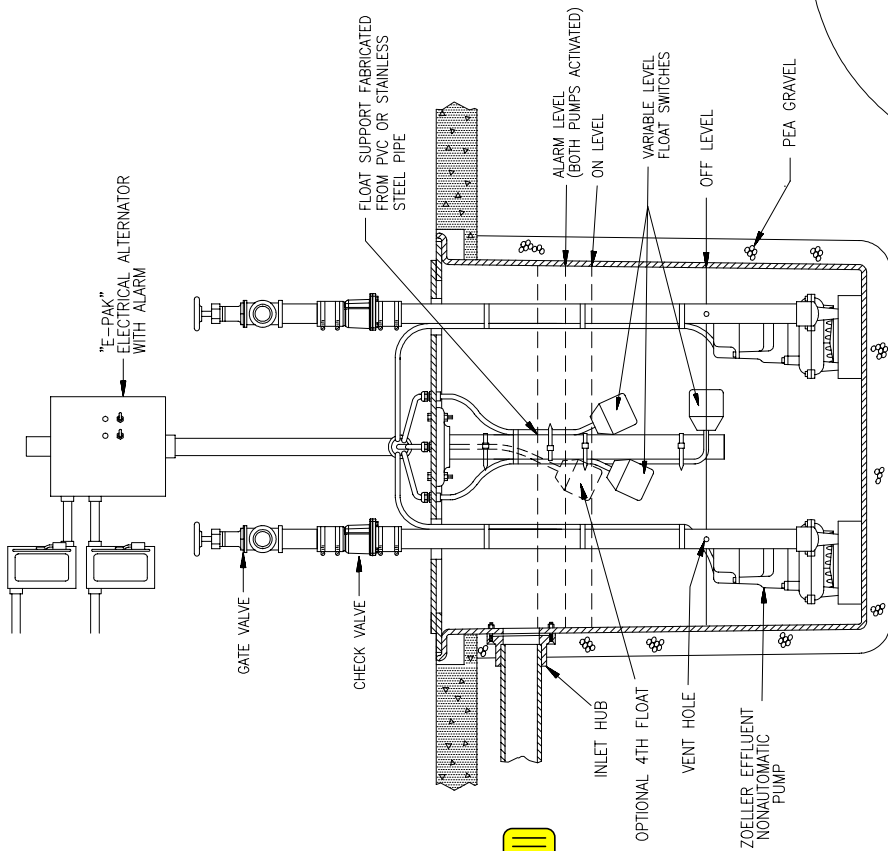

SK500

**DUPLEX ELECTRICAL ALTERNATING SYSTEM
1 OR 3 PHASE EFFLUENT SYSTEM
TOP VIEW**

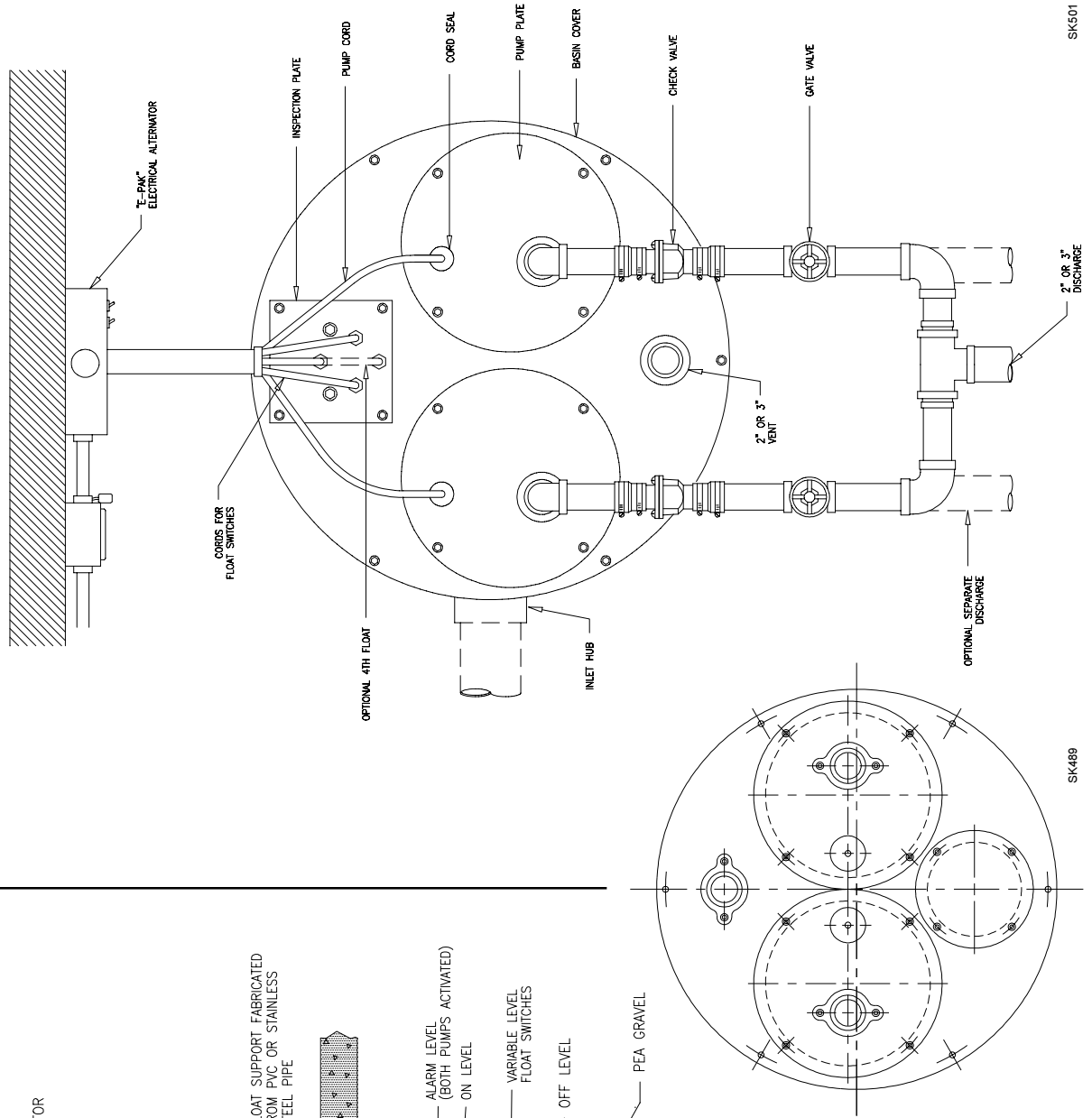

SK489

SK501



EFFLUENT DUPLEX SYSTEM WITH ELECTRICAL ALTERNATOR (Single Phase)

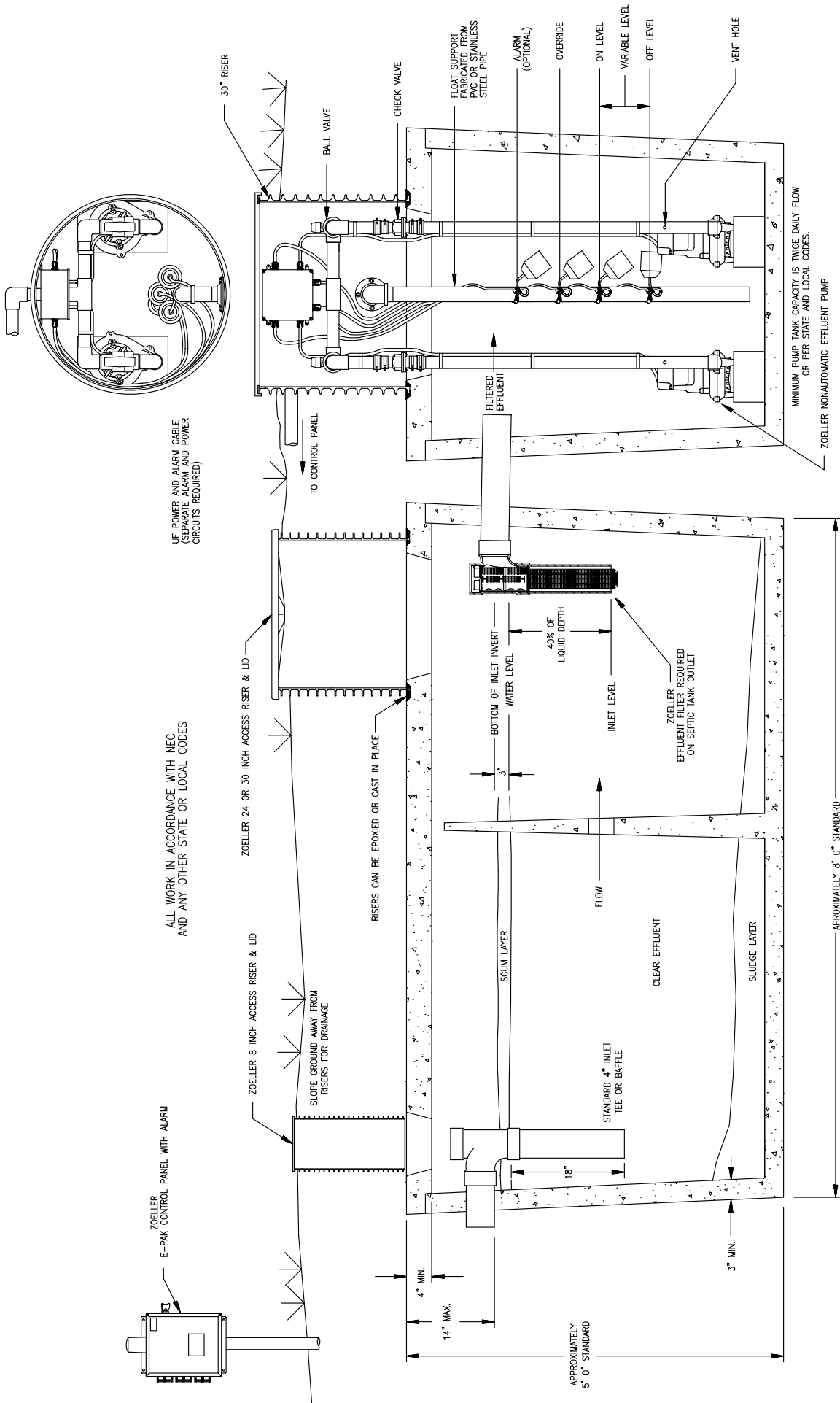

PUMP DISCONNECT SYSTEM

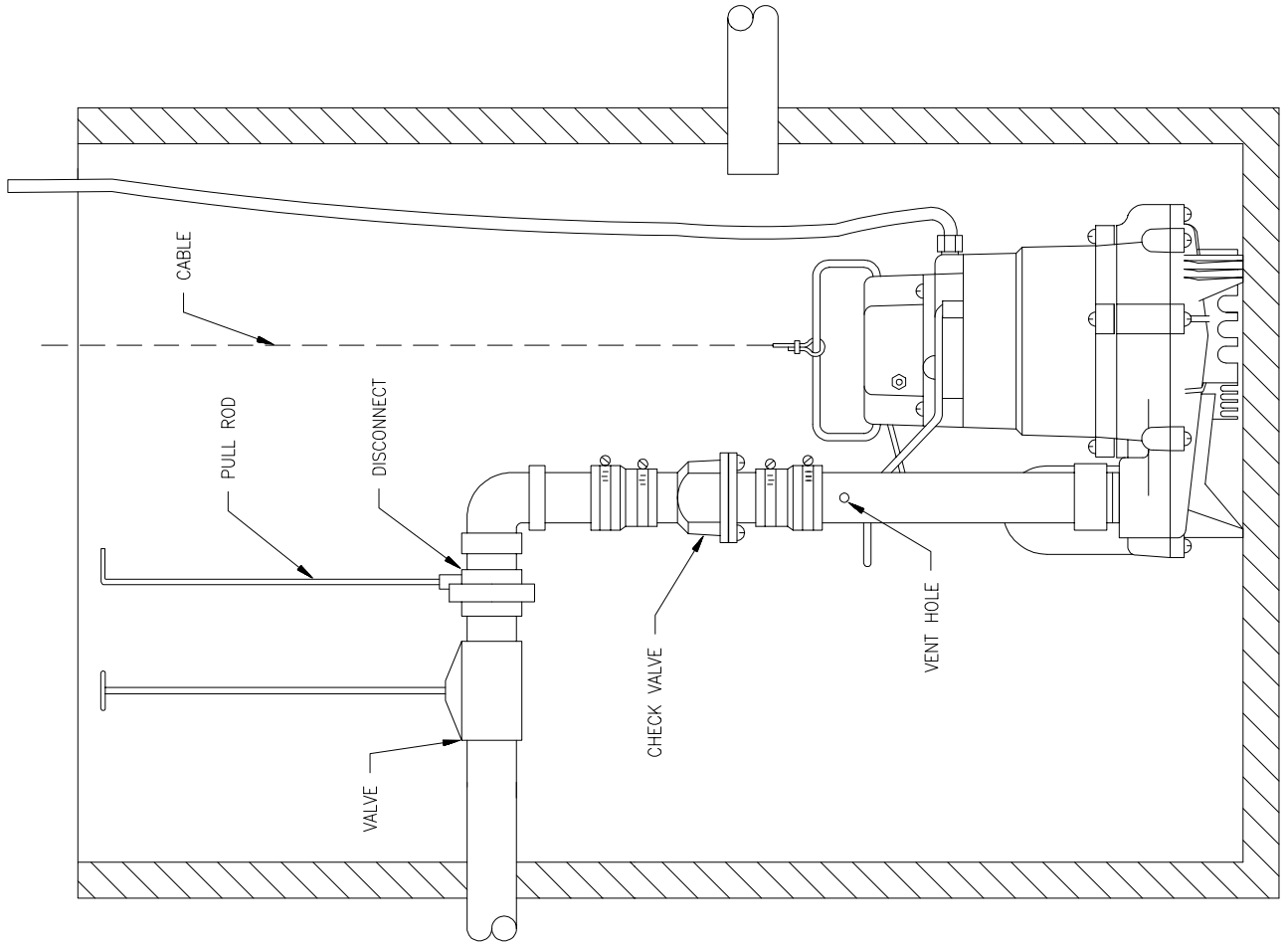

SK1283

PUMP DISCONNECT WITH RAIL SYSTEM

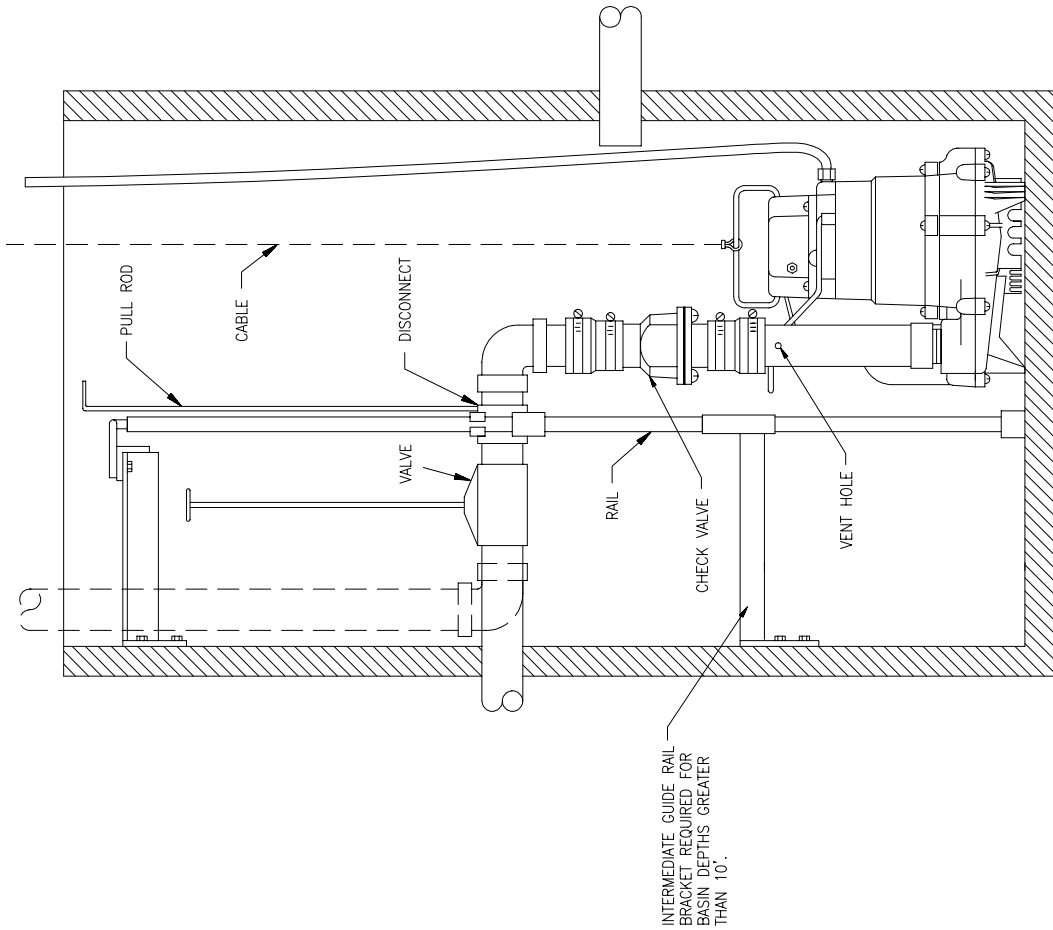

SK1284

SQUARE GUIDE RAIL SYSTEM

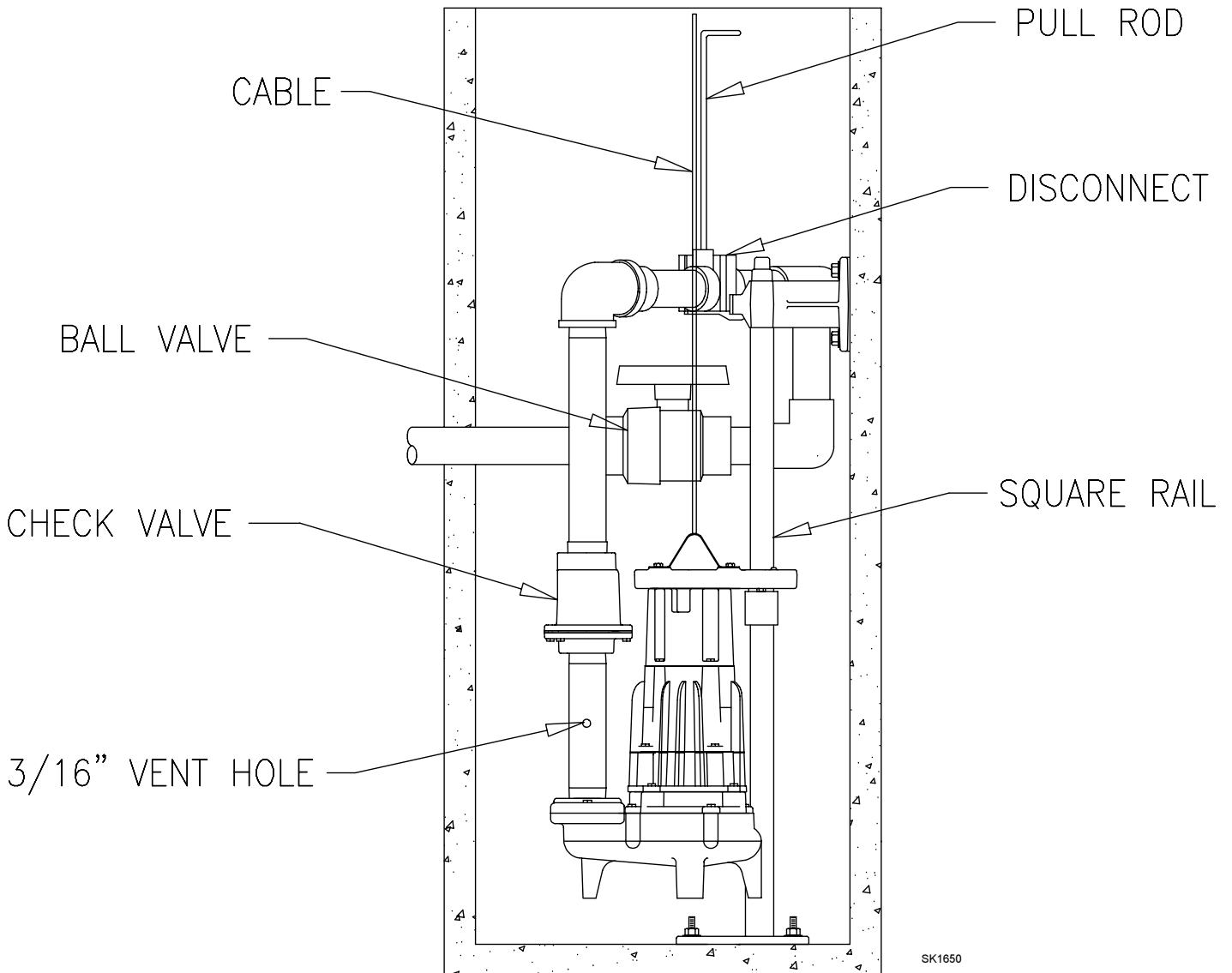
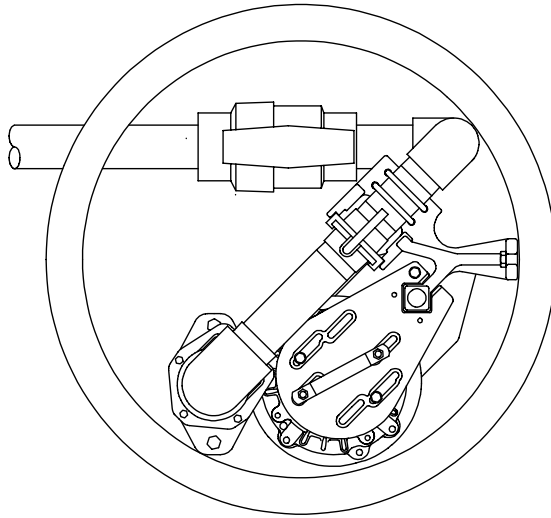

SK1650