

Product information presented here reflects conditions at time of publication. Consult factory regarding discrepancies or inconsistencies.

MAIL TO: P.O. BOX 16347 • Louisville, KY 40256-0347
 SHIP TO: 3649 Cane Run Road • Louisville, KY 40211-1961
 (502) 778-2731 • 1 (800) 928-PUMP • FAX (502) 774-3624

visit our web site:
<http://www.zoeller.com>

SPECIFICATIONS

EFFLUENT/SUMP SIMPLEX SYSTEM

ZOELLER SUBMERSIBLE DEWATERING OR EFFLUENT PUMPS

SEAL	SOLIDS	DISCHARGE	MATERIAL	MODELS							
Single	1/2"	1 1/2" NPT	Cast Iron	53	57	98	140				
Single	1/2"	1 1/2" NPT	Cast Bronze	55	59						
Single	5/8"	1 1/2" NPT	Cast Iron	137	191						
Single	5/8"	1 1/2" NPT	Cast Bronze	139							
Single	3/4"	1 1/2" NPT	Cast Iron	152	153						
Single	3/4"	1 1/2", 2", or 3 NPT	Cast Iron	161	163	165	185	186	188	189	
Double	1/2"	1 1/2"	Cast Iron	4140							
Double	3/4"	1 1/2", 2", or 3 NPT	Cast Iron	4161	4163	4165	4185	4186	4188	4189	

SIMPLEX SYSTEM

Furnish a Zoeller Submersible Pump Model _____ Single Seal or Model _____ Double Seal, with a capacity of _____ GPM against a Total Dynamic Head of _____ feet. Motor Specification: _____ Voltage, _____ Cycles, _____ Phase, _____ HP. Discharge to be _____ 1 1/2 inch NPT. Optional _____ 2" NPT or _____ 3" NPT (161/4161 - 189/4189). Cord length to be _____ feet. Pumps will pass _____ 1/2 inch solids (53,55,57,59, 98 & 140/4140 Series) or _____ 5/8 inch solids (137 & 139 Series) or _____ 3/4 inch solids (152, 153, 161/4161, 163/4163, 165/4165, 185/4185, 186/4186, 188/4188 & 189/4189 Series.) Pumps shall be _____ UL listed, _____ CSA approved, _____ SSPMA certified, _____ State of Wisc. approved, _____ other (Specify _____).

SINGLE PHASE PUMPS GENERAL

Pump motor shall be hermetically sealed, submersible type operating in a high quality dielectric oil for cooling the windings and for lubrication of the motor bearings and ceramic-carbon shaft seal. Single phase motor shall have internal automatic resetting, thermal overload protection. Construction shall be of _____ Cast Iron with 100% baked-on powder coated epoxy finish for corrosion resistance and longer casting durability (or _____ Cast Bronze). All fasteners and external metal parts shall be of stainless steel. Impeller shall be of vortex non-clog design. (Addition noted below.)

Check Applicable Series:

- _____ 53 (cast iron) _____ 55 (cast bronze) Series- Pump shall have a shaded pole motor. Impeller, with metal insert, and base shall be of glass reinforced molded material. Switch case shall be of cast or molded material. Guard and handle shall be of stainless steel.
- _____ 57 (cast iron) _____ 59 (cast bronze) Series- Pump shall have a shaded pole motor. Guard and handle shall be of stainless steel.
- _____ 98 (cast iron) Series - Pump shall have 1/2 HP PSC motor.
- _____ 137 (cast iron) _____ 139 (cast bronze) Series- Pump shall have 1/2 HP split phase motor with current sensing, starting relay enclosed in switch housing.
- _____ 152 (.4 HP) _____ 153 (1/2 HP) series pump shall have a permanent split capacitor motor. The impeller shall

be glass reinforced thermoplastic. Motor housing shall be cast iron.

- _____ 140 (Cast Iron) Series Pump shall have a 1 HP permanent split capacitor motor with capacitor in the switch housing attached to the pump. The impeller shall be cast bronze. Motor housing shall be cast iron. Discharge shall be a permanently affixed 1 1/2" female NPT hub.
- _____ 4140 (Cast Iron) Series Pump with double carbon/ceramic shaft seals shall have a 1 HP permanent split capacitor motor with capacitor in the switch housing attached to the pump. The impeller shall be cast bronze. Motor housing shall be cast iron. Discharge shall be a permanently affixed 1 1/2" female NPT hub. The lower seal cavity shall be oil-filled.
- _____ 161 (1/2 HP) _____ 163 (1/2 HP) _____ 165 (1 HP) Cast Iron Series- Pump shall have a permanent split capacitor motor with run capacitor and magnetic contactor enclosed in switch housing. Impeller shall be of cast bronze. Motor housing shall be finned for extra cooling capability.
- _____ 4161 (1/2 HP) _____ 4163 (1/2 HP) _____ 4165 (1 HP) Cast iron series pump with double carbon/ceramic shaft seals shall have a permanent split capacitor motor with run capacitor and magnetic contactor enclosed in the switch housing. Impeller shall be cast bronze. Motor housing shall be finned for extra cooling capability. The lower seal cavity shall be oil-filled.

_____ 185 (1 HP) _____ 186 (1½ HP) _____ 188 (1½ HP)
_____ 189 (2 HP) Cast Iron Series- Pump shall have a permanent split capacitor motor with run capacitor and magnetic contactor enclosed in switch housing. Impeller shall be of cast bronze. Motor housing shall be finned for extra cooling capability.

_____ 4185 (1 HP) _____ 4186 (1½ HP) _____ 4188 (1½ HP) _____ 4189 (2 HP) Cast iron series pump with double carbon/ceramic shaft seals shall have a permanent split capacitor motor with run capacitor and magnetic contactor enclosed in the switch housing. Impeller shall be cast bronze. Motor housing shall be finned for extra cooling capability. The lower seal cavity shall be oil-filled.

_____ 191 (2 HP) Cast iron series pump with carbon/ceramic shaft seals shall have a permanent split capacitor motor with run capacitor enclosed in the switch housing. Impeller shall be cast bronze and the housing shall be epoxy coated. Impeller shall be of a closed type construction. Motor housing shall be finned for extra cooling capability.

AUTOMATIC CONTROL - INTEGRAL FLOAT TYPE

Single phase pump shall have an integral mechanical float switch, which shall require no adjustment, nor require additional equipment for operation.

AUTOMATIC CONTROL PIGGYBACK VARIABLE LEVEL FLOAT SWITCH

A Zoeller _____ Piggyback Variable Level Float Switch with a fifteen (15) foot SJOWA cord and molded plug shall be furnished to control a nonautomatic pump. Control shall be constructed of durable plastic and be omnidirectional. Control shall be fastened to discharge pipe with plastic tie mounting strap and shall require no extra wiring. (Addition Noted Below.)

Check Applicable Control:

_____ 10-0034 (115V/Max. ½ HP) or _____ 10-0035 (230V/Max. 2 HP) (For use on 115V or 230V, 1 Phase, nonautomatic Zoeller pump). Designed for automatic pump operation with the appropriate voltage and horsepower, single phase, Zoeller pump.

_____ 10-0229 (115V/Max. 1 HP) or _____ 10-0230 (230V/Max. 2 HP) (For use on 115V or 230V, 1 Phase, nonautomatic Zoeller pump.) Double float system shall have an adjustable pumping range. Pumping range shall be a minimum of one (1) inch to a maximum of forty-eight (48) inches.

SIMPLEX CONTROL PANEL

A Zoeller _____ Simplex Control Panel shall be furnished to control a nonautomatic pump. The panel shall have a Nema 4x enclosure, pump run indicator light, high water alarm, selector switches, float switches, and UL label. Panel will be sized for Zoeller Model _____, _____ Volt, _____ Cycle, _____ Phase, _____ HP, _____ FLA pump.

THREE PHASE SYSTEM (FOR USE WITH 130, 160/4160, or 180/4180 SERIES ZOELLER PUMP) GENERAL

Pump motor shall be hermetically sealed, submersible type, operating in a high quality dielectric oil for cooling the windings and for lubrication of the motor bearings and ceramic-carbon shaft seal. Pump motor shall have external magnetic contactor and overload protection. All fasteners and external metal parts shall be of stainless steel. Impeller shall be of vortex non-clog design.

_____ 137 (cast iron) model _____ 139 (cast bronze) model shall have a 4-pole squirrel cage induction motor.

_____ 161 (½ HP) _____ 163 (½ HP) _____ 165 (1 HP) cast iron series shall have a 2-pole squirrel cage induction motor. Impeller shall be cast bronze. Motor housing shall be finned for extra cooling capability.

_____ 4161 (½ HP) _____ 4163 (½ HP) _____ 4165 (1 HP) cast iron series pump with double carbon/ceramic shaft seals shall have a 2-pole squirrel cage induction motor. Impeller shall be cast bronze. Motor housing shall be finned for extra cooling capability. The lower seal cavity shall be oil-filled.

_____ 185 (1 HP) _____ 186 (1½ HP) _____ 188 (1½ HP) _____ 189 (2 HP) _____ cast iron series shall have 2-pole squirrel cage induction motor. Impeller shall be cast bronze. Motor housing shall be finned for extra cooling capability.

_____ 4185 (1 HP) _____ 4186 (1½ HP) _____ 4188 (1½ HP) _____ 4189 (2 HP) _____ cast iron series pump with double carbon/ceramic shaft seals shall have 2-pole squirrel cage induction motor. Impeller shall be cast bronze. Motor housing shall be finned for extra cooling capability. The lower seal cavity shall be oil-filled.

SIMPLEX CONTROL PANEL

A Zoeller _____ Simplex Control Panel with three 10-0225 Control Switches shall be furnished to control a nonautomatic pump. The panel shall have a Nema 4X enclosure, pump run indicator light, high water alarm, selector switches, and a UL label. Panel will be sized for Zoeller Model _____, _____ Volt, _____ Cycle, _____ Phase, _____ HP, _____ FLA pump.

Panels used with double seal pumps with optional moisture sensors will require a seal leak detector light.

CONTROL SWITCHES

A Zoeller Variable Level Float Switch shall be furnished to operate control circuit. Float shall be omnidirectional and include a fifteen (15) foot SJOWA cord and plastic tie mounting strap.

ACCESSORIES/MISCELLANEOUS UNICHECK

_____ 30-0200, (Clamp union valve)(1¼/1½ inch) full flow check valve, rated at 4.3 psi (10 feet TDH) at 130° deg. F. shall be furnished to fit 1¼ inch 1½ inch ABS, PVC, CPVC, steel or copper piping. Unicheck shall have valve body and seat of PVC plastic and shall be assembled with thru bolts. Gasket and flapper shall be neoprene with brass backing plates and stainless

steel rivet. Unichheck shall include two (2) neoprene unions and four (4) stainless steel clamps and fasteners. _____ 30-0021, (Clamp union valve) (2 inch) full flow check valve, rated at 4.3 psi (10 feet TDH) at 130° deg. F. shall be furnished to fit 2 inch ABS, PVC, CPVC, steel or copper piping. Unichheck shall have valve body and seat of PVC plastic and shall be assembled with thru bolts. Gasket and flapper shall be neoprene with brass backing plates and stainless steel rivet. Unichheck shall include two (2) neoprene unions and four (4) stainless steel clamps and fasteners.

_____ 30-0015 (Compression Union Valve) 1½ inch IPS full flow check valve shall be furnished to fit 1½ inch IPS pipe. Unichheck body and compression and fittings shall be constructed of PVC. Flapper and end seals shall be Buna-N. Valve shall include no metallic parts. Pressure rated at 25 PSI (57 feet TDH) at 130° F.

_____ 30-0152, (2 inch) cast iron full flow check valve with 2" female N.P.T. Rated at 50 PSI (115 feet TDH) at 130° F. Neoprene polyester reinforced flapper with cast iron and brass backing plates and stainless steel fastener.

_____ 30-0160 (3 inch) cast iron full flow check valve with 3" female N.P.T. Rated at 50 PSI (115 feet TDH) at 130° F. Neoprene polyester reinforced flapper with cast iron and brass backing plates and stainless steel fastener.

OPTIONAL ALARM SYSTEM

An audible high water alarm system shall include a Zoeller _____ 10-0015 (115V) or _____ 10-0016 (230V) A-Pak and a 10-0225 Variable Level Float Switch. The A-Pak shall include a six (6) inch steel alarm bell, which shall sound sixty-eight (68) decibels at a distance of ten (10) feet and a dual mount transformer, which shall step down 115V or 230V 1 PH line voltage to 8V. The 10-0225 Variable Level Float Switch shall be constructed of plastic and shall be omnidirectional. Float shall include fifteen (15) foot SJOWA cord and shall be fastened to discharge pipe with plastic tie mounting strap.

_____ 10-0053 (115V/1Ph) A-Pak complete with sensor float and Nema 1 metal enclosure (cord and plug). Solid state warning light and horn, which can be manually turned off. UL listed and CSA certified on complete alarm system.

_____ 10-0126 (115V/1Ph) High level Alarm complete with Nema 4x enclosure, alarm bell, Alarm light, Silence switch, and sensor float switch with 15' cord. Entire unit is UL Listed and CSA Certified.

_____ 10-0623 (115V/IPH) High Level Alarm rated for Indoor/Outdoor use per UL 864. The alarm will include an alarm horn, alarm light, silence and test buttons, and a 15' float switch.

_____ 10-0682 (115V/1Ph) deluxe high level alarm rated for indoor/outdoor use per UL 864. The alarm will include an alarm horn, alarm light, silence and test buttons, a 20' float switch, 6' power cord, and watertight connectors.

SUMP BASIN

A Zoeller _____ polyethylene basin, .200 inch thick, .949 G/CC dense, or Zoeller _____ fiberglass basin, 3/16 inch thick, .058 pounds/cubic feet dense, _____ inches inside diameter by _____ inches deep shall be furnished. The basin shall include _____ four (4) inch cast iron caulk inlet hubs with anticorrosion coating. The center-line of the hub(s) shall be located nine (9) inches from the top of the basin. The basin shall also include a .115 inch thick steel sump cover. An optional pump installation plate can be provided on covers twenty-four (24) inches in diameter or larger. Optional anti-floatation ring can also be provided. Also included shall be a neoprene seal for pump cord, neoprene seal for vent and discharge flange, foam cover seal and plated steel fasteners. Cover shall include a _____ inch vent a _____ inch discharge flange with mounting hardware.

PIPING & POWER WIRING

All piping shall be rigid and permanent in nature and shall be furnished and installed by the contractor. A unichheck shall be installed in the discharge pipe. A 3/16" vent hole shall be drilled in the discharge pipe below the check valve and pit cover to purge the system of trapped air. Power wiring shall be supplied by electrical contractor. Power wiring for pumping system and alarm system shall be connected to separate circuits.

EXTRA DUTY

Where conditions require, specify extra duty for adverse conditions.

HIGH TEMPERATURE PUMPS

For applications up to 200° F. continuous operation, specify High Temperature Zoeller Pump Co. models. See literature on High Temperature pumps, FM0806 and FM0807, for additional information. For 200° F. specification sheet, see FM0817.

PUMP DISCONNECTS AND RAIL SYSTEMS

Where conditions, due to safety, health and the economy of maintenance require pump disconnects or rail systems specify:

- _____ 39-0001, 1½" NPT Disconnect (Non-pump Supporting)
- _____ 39-0002, 2" Disconnect (Non-pump Supporting)
- _____ 39-0003, 1½" NPT Rail System (Non-pump Supporting)
- _____ 39-0004, 2" NPT Rail System (Non-pump Supporting)
- _____ 39-0085, 1½" NPT Galv. Ez Out (Pump Supporting)
- _____ 39-0086, 1½" NPT S.S. Ez Out (Pump Supporting)
- _____ 39-0083, 2" NPT Galv. Ez Out (Pump Supporting)
- _____ 39-0084, 2" NPT S.S. Ez Out (Pump Supporting)
- _____ 39-0074, 3" NPT Galv. Ez Out (Pump Supporting)
- _____ 39-0075, 3" NPT S.S. Ez Out (Pump Supporting)

Square Guide Rail Systems shall include single rigid stainless steel square rail design, red brass disconnect fitting, cast iron angle arm bracket and guide plates. _____ Galvanized or _____ stainless piping, PVC ball valve, cast iron check valve. Rail system shall be for a Zoeller Model _____ with a _____ inch discharge. Rail system will be for a _____ inch diameter basin.

**SUMP SIMPLEX SYSTEM WITH DOUBLE VARIABLE LEVEL FLOAT SWITCH
(SINGLE PHASE)**

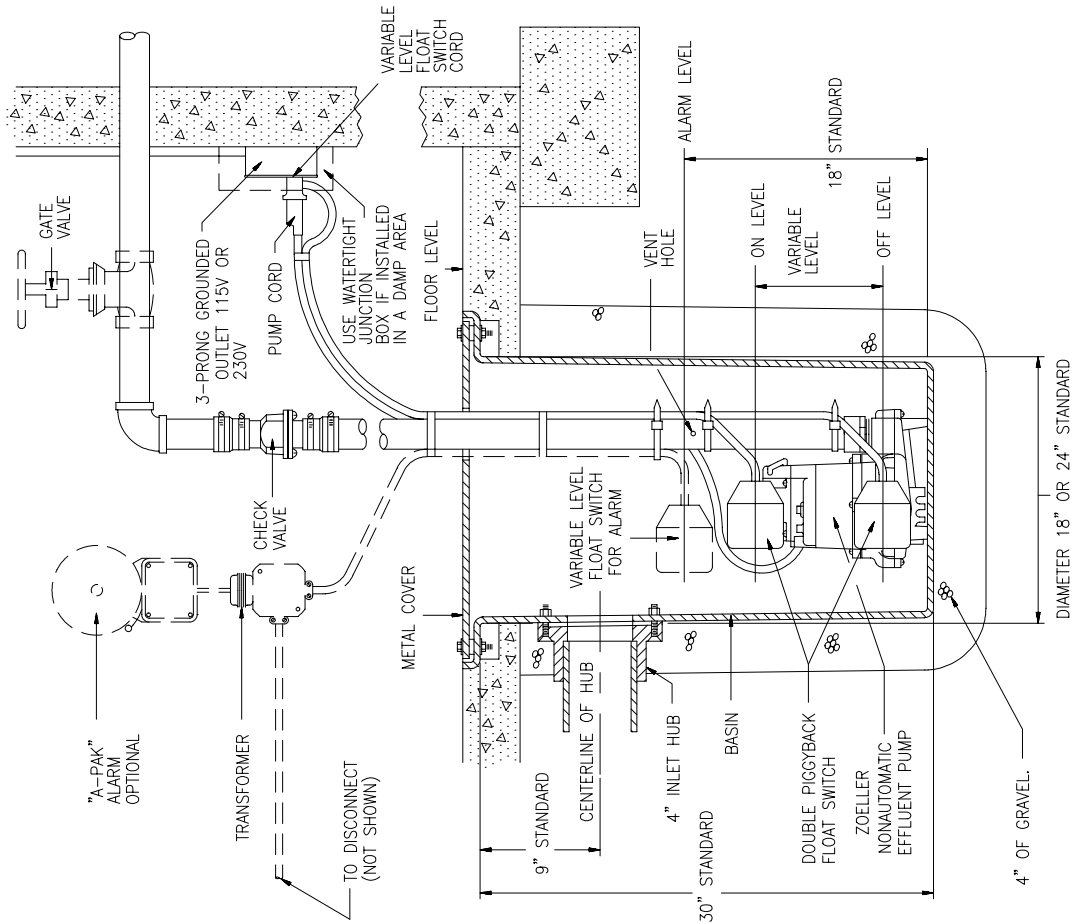

SK454

**SUMP SIMPLEX SYSTEM WITH SINGLE VARIABLE LEVEL FLOAT SWITCH
(SINGLE OR THREE PHASE)**

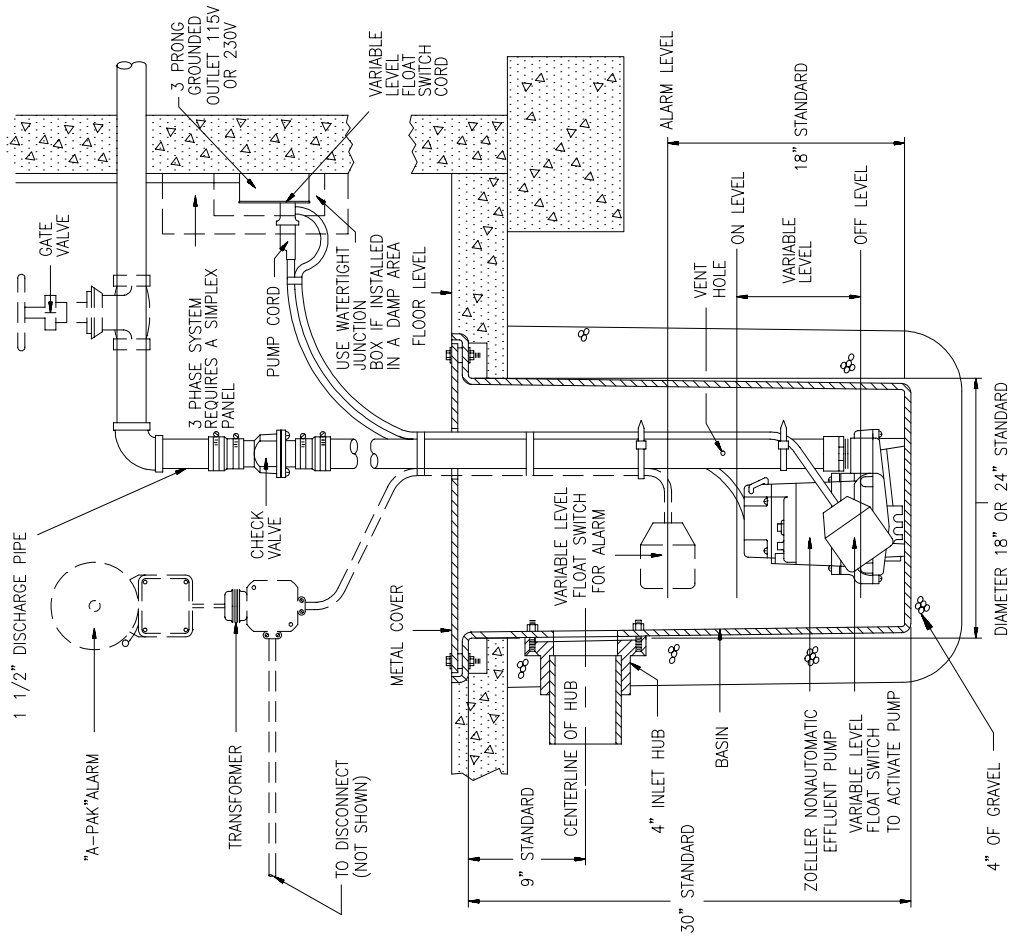

SK453

**SUMP SIMPLEX SYSTEM WITH INTEGRAL SWITCH
(SINGLE PHASE)**

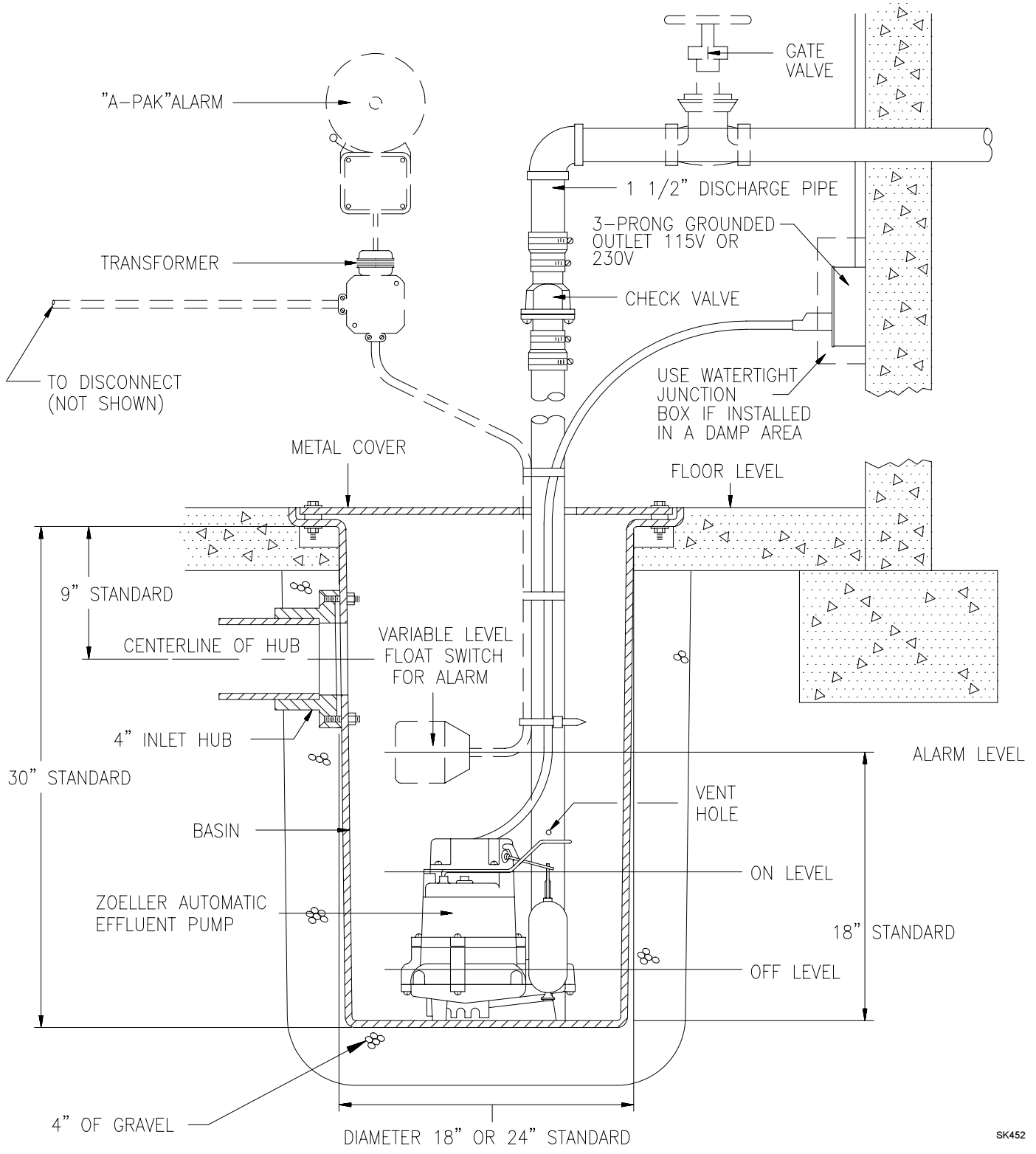

SK452

EFFLUENT SIMPLEX SYSTEM WITH DOUBLE VARIABLE LEVEL FLOAT SWITCH (SINGLE PHASE)

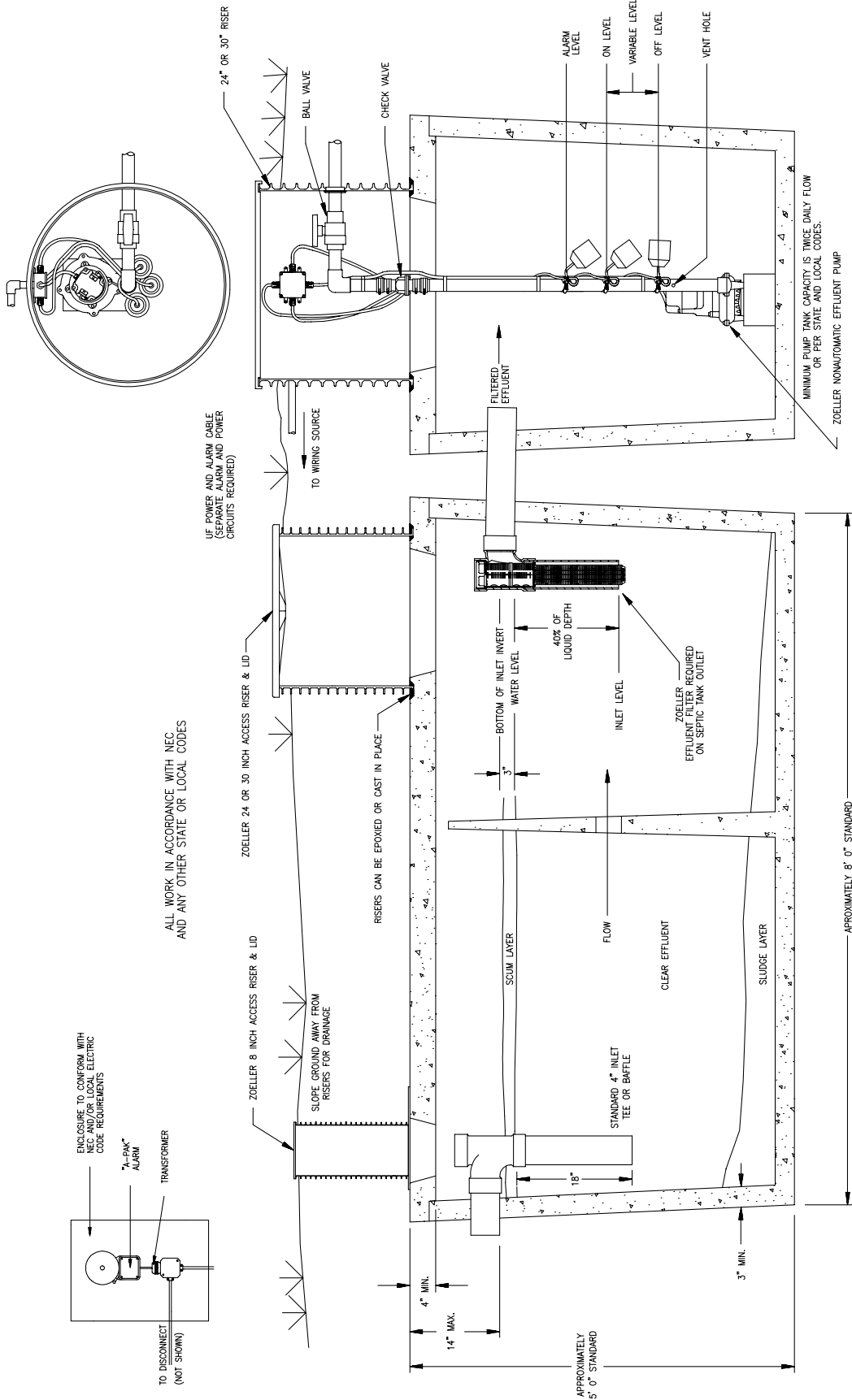

EFFLUENT SIMPLEX SYSTEM WITH SINGLE VARIABLE LEVEL FLOAT SWITCH (SINGLE PHASE)

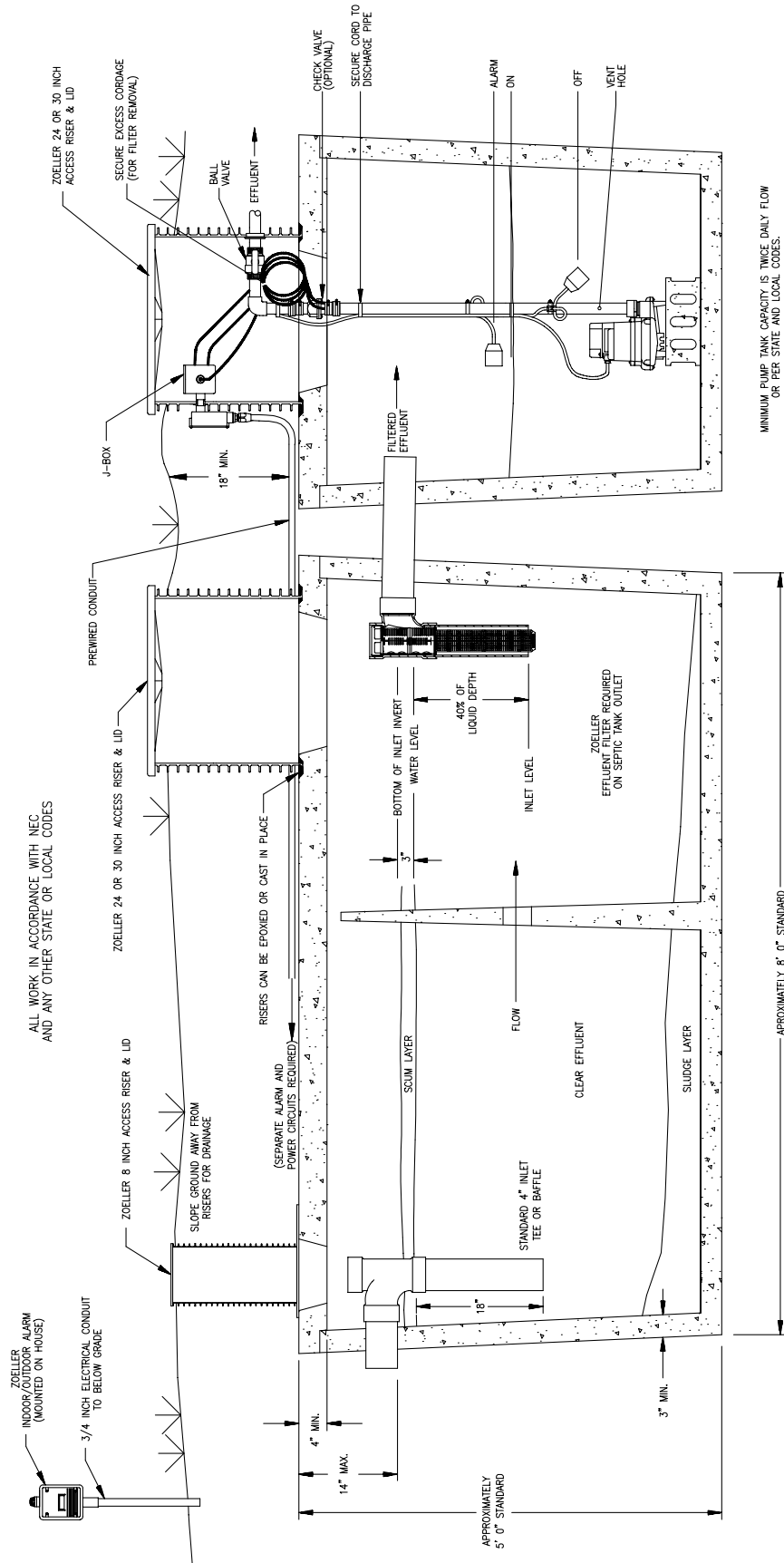

SQUARE GUIDE RAIL SYSTEM

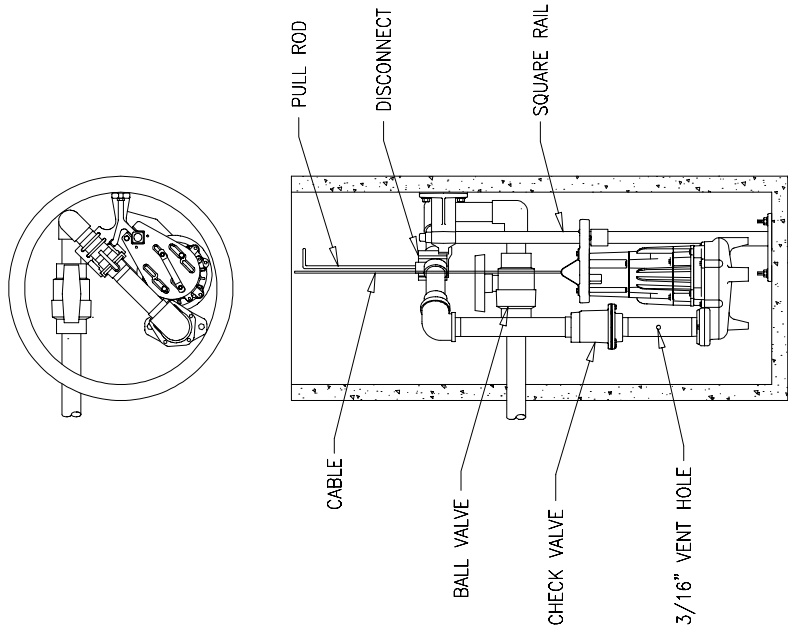

SK1650

PUMP DISCONNECT WITH RAIL SYSTEM

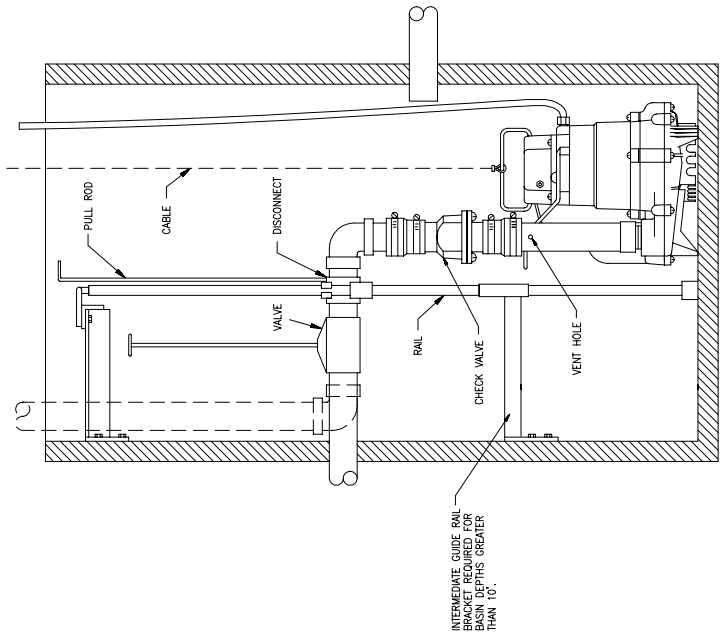

SK1284

PUMP DISCONNECT SYSTEM

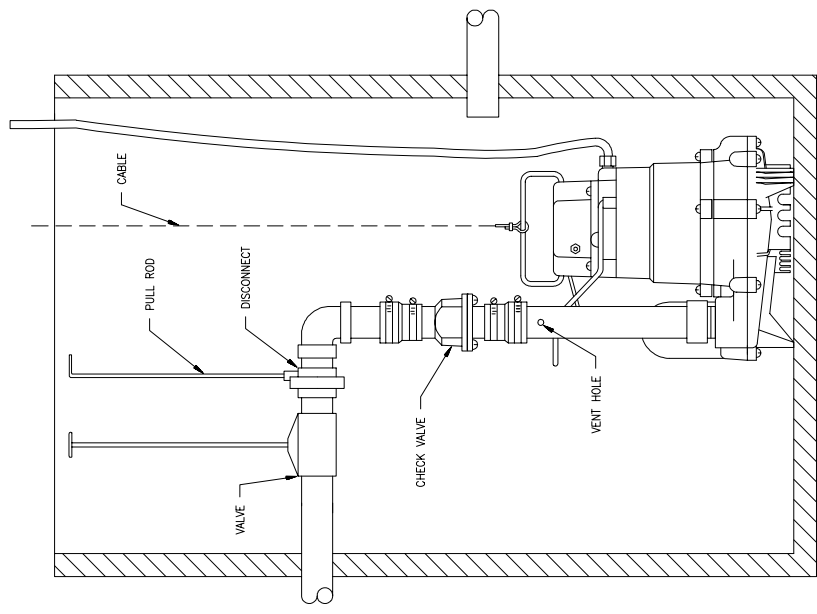

SK1283