

# Ampco Centrifugal Pumps

DATA SHEET

MODEL EP/EPH 3 X 2 1/2

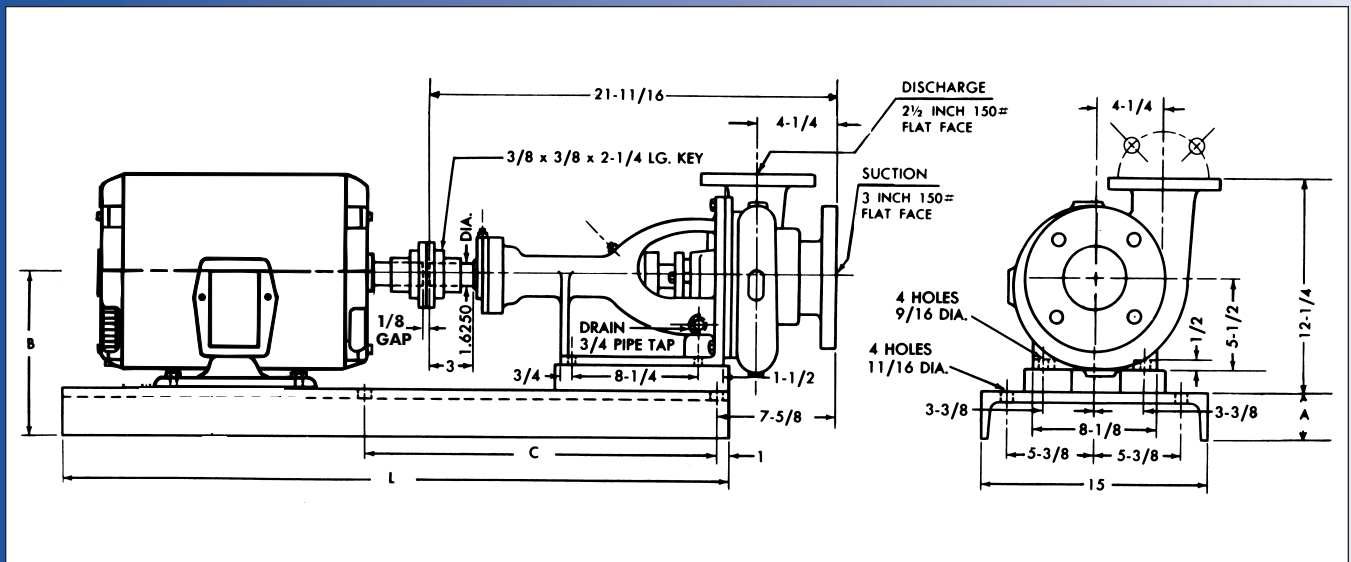
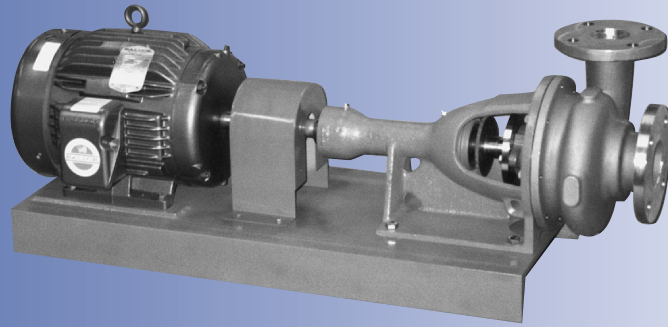

TEFC MOTOR			DIMENSIONS IN INCHES (For Reference Only)			
HP	RPM	FRAME	A	B	C	L
7-1/2	3500	213T	3-7/8	9-3/8	19	36-3/4
10	3500	215T	3-7/8	9-3/8	19	36-3/4
15	3500	254T	4-1/8	9-5/8	23	41-1/2
20	3500	256T	4-1/8	9-5/8	23	41-1/2
25	3500	284T	4-7/8	10-3/8	23	45-1/2

## MATERIAL SPECIFICATIONS

PART NAME	NICKEL ALUMINUM BRONZE	STAINLESS STEEL
Casing, Cover & Impeller	AMPCO® 483	316 Stainless
Wear Ring	AMPCO® 18	316 Stainless
Shaft	Steel	Steel
Shaft Sleeve	AMPCO® 18	316 Stainless
Frame	Cast Iron	Cast Iron

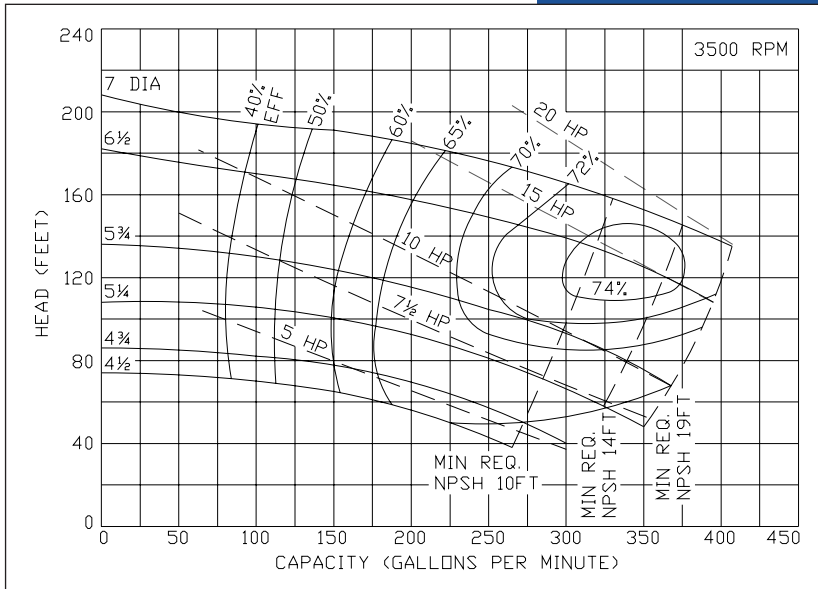

# Ampco Centrifugal Pumps

## MODEL EP/EPH 3 X 2 1/2

Curves show approximate characteristics based on clear 68° water. Rated point is guaranteed.

E Series pumps provide the same heavy-duty construction and hydraulic performance as Ampco's Z Series.

An enlarged stuffing box offers multiple sealing arrangements, including Type 21, Type 1, Type 9, Double Type 21, Double Type 9, packing and cartridge seals.

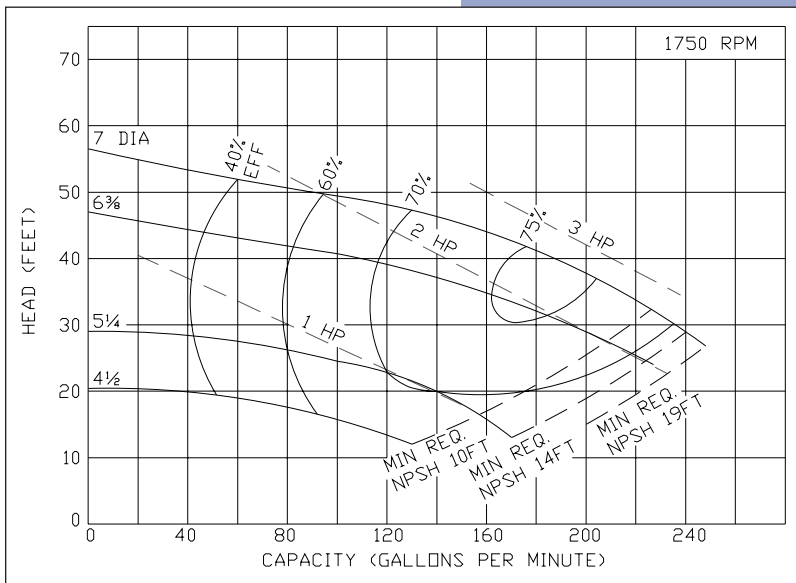
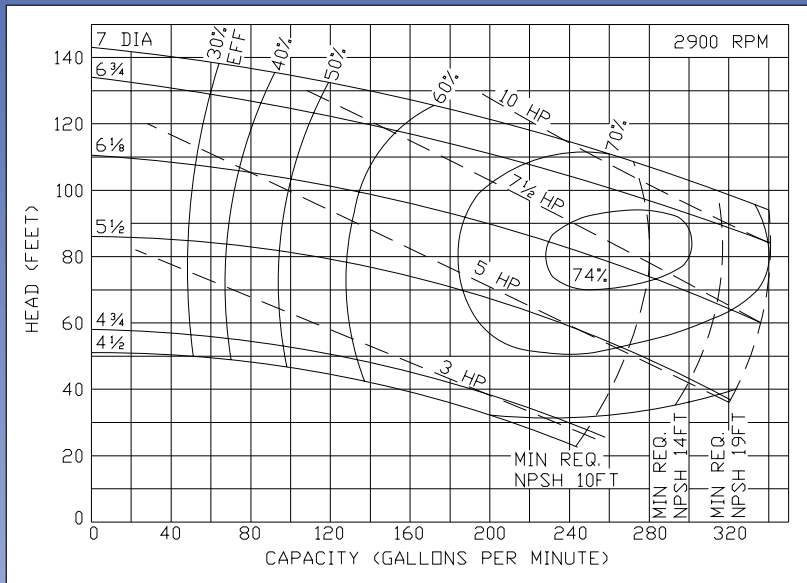

# Ampco Pumps Company

4424 West Mitchell Street  
 Milwaukee, Wisconsin 53214  
 PHONE (414) 643-1852  
 FAX (414) 643-4452