

MF Series Water Softeners

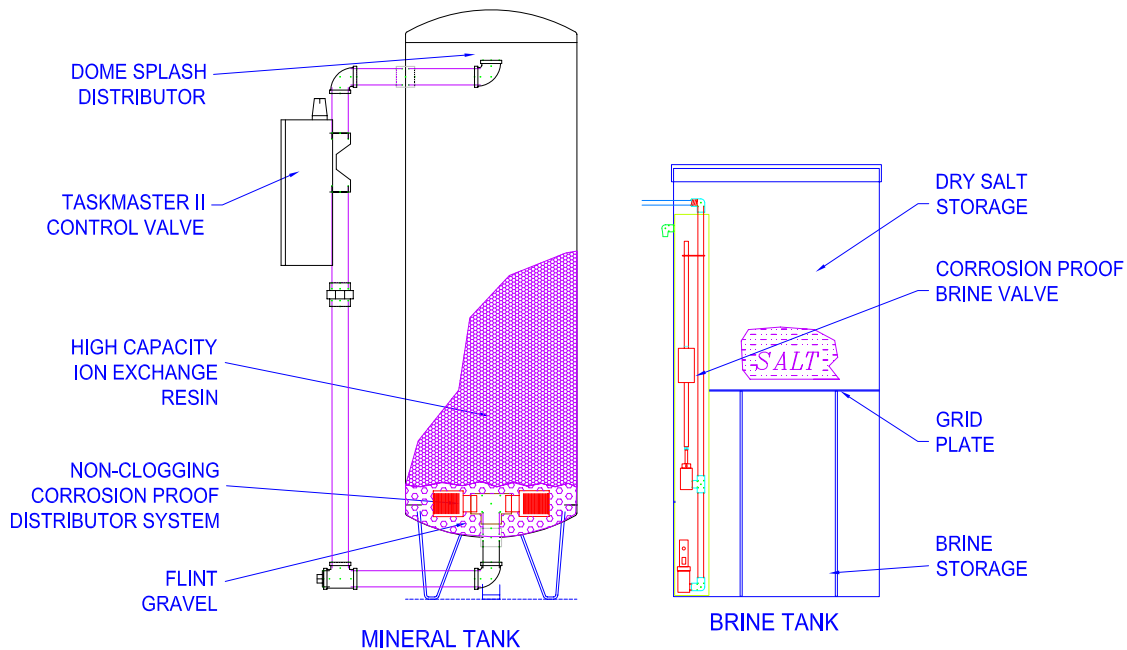

STANDARD

TASK MASTER III™ - 1 ½" VALVE – 316 SS -
SIDE MOUNT

SERVICE FLOW BYPASS DIAPHRAGM VALVES.

ERCt ELECTRONIC TIMER

100 PSI EPOXY LINED AND COATED CARBON
STEEL MINERAL TANKS

ACCUMATIC™ BRINE SYSTEM.

RESIN POLYSTYRENE 8% DVB CL

MULTIPLE POINT ABS DISTRIBUTOR

110V, 60Hz, 1Ø

OPTIONS

ASME CODE TANKS

HIGH TEMPERATURE AND PRESSURE

DEMAND INITIATION

TWIN CONFIGURATION WITH ELECTRONIC
TIMERS

TWIN ALTERNATING WITH ERCd AND PW
SERIES METER

SHUT OFF KIT (SOK) TO PREVENT BYPASS
DURING REGENERATION

PRESSURE GAUGE AND TEST TAP KIT

SKID MOUNTING

220V, 50Hz, 1Ø

OPERATING CONDITIONS

25 TO 100 PSI • 100°F MAX TEMP

MF Series Sizing Information											
	Dia. X Side Shell (in.)	Capacity (Kgr)	Salt Applied (lbs)	Continuous Flow (gpm) ²	Peak Flow (gpm) ³	Back-wash ⁴ (gpm)	Resin (ft ³)	Gravel (lbs)	Brine Tank (in)	Salt Storage (lbs)	Brine Valve (in)
MF-150-1½	20x54	153	66	49	65	10	5	100	24x40	500	3/8
MF-150S-1½				50	68						
MF-150S-2				50	75						
MF-180-1½	20x54	196	106	48	64	10	6	100	24x50	580	3/8
MF-180S-1½				50	67						
MF-180S-2				60	90						
MF-240-1½	24x54	245	106	51	67	15	8	150	24x50	580	3/8
MF-240S-1½				54	71						
MF-240S-2				80	120						
MF-300-1½	30x60	293	106	55	71	25	10	250	24x50	580	3/8
MF-300S- 1½				58	75						
MF-300S-2				100	150						
MF-300S-2½				100	150						
MF-300S-3				100	150						
MF-450-1½	30x60	432	145	53	70	25	15	250	30x50	900	1/2
MF-450S-1½				56	74						
MF-450S-2				110	146						
MF-450S-2 ½				150	213						
MF-450S-3				150	225						
MF-600-1½	36x60	594	244	55	72	35	20	350	39x60	2,040	1/2
MF-600S-1½				58	76						
MF-600S-2				119	156						
MF-600S-2½				176	236						
MF-600S-3				200	300						
MF-750-1½	36x72	731	244	55	71	35	25	350	39x60	2,040	1/2
MF-750S-1½				58	75						
MF-750S-2				116	152						
MF-750S-2 ½				168	225						
MF-750S-3				214	296						
MF-900-1½	42x72	837	274	56	73	50	30	500	42x60	2,370	1
MF-900S-1½				59	77						
MF-900S-2				123	160						
MF-900S-2½				189	249						
MF-900S-3				254	342						
MF-900S-4				300	450						

MF Series Sizing Information

	Dia. X Side Shell (in.)	Capacity (Kgr)	Salt Applied (lbs)	Continuous Flow (gpm) ²	Peak Flow (gpm) ³	Back-wash ⁴ (gpm)	Resin (ft ³)	Gravel (lbs)	Brine Tank (in)	Salt Storage (lbs)	Brine Valve (in)
MF-1200-1½	48x72	1,170	388	57	74	60	40	1,100	50x60	3,360	1 ¼
MF-1200S-1½				60	78						
MF-1200S-2				126	163						
MF-1200S-2½				194	254						
MF-1200S-3				274	364						
MF-1200S-4				398	546						
MF-1200S-6				400	600						

NOTES ON APPLICATION TABLE:

- Capacities listed are based on 20 grains per gallon at intermittent flow rates, and are 95% of lab results
- Continuous flow rates are listed at 10 gpm/ft³ of resin or 15 psi pressure drop, which ever is less.
- Peak flow rates are listed at 15 gpm/ft³ of resin or at 25 psi pressure drop, which ever is less.
- Drains at installation sites must be able to dispose of water at the backwash rate for periods up to 20 minutes.
- Dimensions listed are actual unit height. At least one additional foot should be allowed for loading mineral tanks.

MF SERIES SPECIFICATION (MF 150 TO 1200 UP TO 3" PIPING)

Mineral Tank (Standard Non Code Vessels). The non-code vessel shall be A36 carbon steel or better rated at 100 psi working pressure designed to a factor of safety of 3.0. The inlet and outlet shall be 3000 psi NPT full couplings. The inlet shall be in the side wall and the outlet shall be in the center of the tank bottom shell. Each tank shall have a top center fitting. Tanks 36" Ø and larger shall have lifting lugs. Tanks 20, 24, and 30" Ø inch tanks shall have a 4" x 6" handhole in the side shell and in the top head. Tanks 36" Ø and larger shall have a 4" x 6" handhole in the top dome and an 11" x 16" or larger manway in the side shell.

Mineral Tank (Optional Code Vessels). ASME code stamped tanks shall be available. Tank shall be clearly specified as code or non-code with a specified working pressure. Tanks "built to ASME code but not stamped" shall not be acceptable as ASME code. An ASME U1 form shall be provided with each ASME code tank.

Coating and lining. Tanks shall be prepared for internal and external coating with a SPCC 11 near white sand blast. Internal and external coating shall be two - 3 to 4 mill coats of white Series 20 Tnemec Epoxy. Paint shall be applied according to manufacturer's recommendations. Paint reports and mill thickness reports shall be provided if requested at the time the tank is ordered.

Internals. The bottom distributor shall be a multipoint system using 2½" Ø single point molded distributor heads with 2½" of slotted length and a 1½ inch NPT female threaded connection. The slots shall be .012" - .016" wide to retain mineral and the total slot area shall be equal to or larger than the unit pipe size. A top

CAT231.4

dome splash distributor with an opening equal to or larger than the unit pipe size shall be installed in the mineral tank. The internal distributor piping shall be SCH 80 PVC.

Piping. The softener(s) shall ship with face piping mounted on the vessels. Face piping shall be schedule 40 galvanized carbon steel with NPT fittings for 1 ½" and 2" piping. Piping for superflow or service flow bypass shall be schedule 40 grooved fitting galvanized carbon steel.

Media. The resin shall be sodium form polystyrene 8% divinyl benzene cross linked resin with clear spherical beads. Resin beads shall be 16-50 US Standard Mesh with a particle size range of 0.3 to 1.2 mm. The resin shall be clean and packaged in sealed plastic bags weighing 55 lbs or less. Underbedding shall be #20 graded washed flint gravel sieved between 1/8" and 1/16".

Brine System. The brine system shall be of the Accumatic™ high grid plate design. The brine tank shall be blow molded or rotationally molded HDPE, including a cover. The system shall include a SCH 80 PVC float operated brine valve to control refill shut-off and refill flow rate. Brine volume is to be repeatedly accurate within 10% and not dependent on salt bed void space for brine volume. Brine draw is to volumetrically controlled, not timed.

Control Valve Specifications. The main control valve(s) shall be the Task Master III™ with electronic controller to actuate the cycles of backwash, brine, slow rinse, fast rinse, and service for a water softener (or backwash, rinse and service for a filter). The control valve(s) shall be Task Master III™ 5-Cycle, multi-port control valve(s) with machined passivated CF8M Type 316 Stainless Steel body, Type 316 Stainless Steel piston assembly, and EPDM (NSF61 and WRAS Approved) inserts and seals with electronic controller and drive motor assembly in a NEMA 4/IP65 Style Enclosure. The valve shall operate with a single motor driven piston positioned by optical sensors. Valve inlet and outlet shall be 1 ½" FNPT. Backwash drain shall be ¾" or 1 ½" depending on flow. The brine inlet shall be ½". The one piece brine eductor shall be installed in the valve. The valve shall be equipped with threaded ¼" FNPT ports for the installation of sample taps and pressure gauges. (Taps and gauges are optional.) Hard water by-pass shall be available during all regeneration cycles at 70 gpm or at the peak flow rate of the unit, at a pressure drop less than 25 psi, whichever is less. No hard water bypass option is obtained by adding a shut off kit to the valve. The valve shall be of a single piston design and shall not use multiple plungers or diaphragm valves. Maximum rated power shall be 125 watts with available current options of 115 VAC, 230 VAC, 100 VAC, 200 VAC, in 50 or 60 Hertz. Ambient operating temperature range shall be 34°F (1°C) to 150°F (65°C). Fluid temperature range shall be 34°F (1°C) to 180°F (82°C). Operating pressure range shall be 20-125 psi (1.38 - 8.6 bar). The valve shall have UL, CSA, TÜV and CE certifications. ANSI/NSF 61 certification is pending.

Super Flow Systems (-S). A Super Flow Kit (SFK) shall consist of an inlet and an outlet diaphragm valve operated by a solenoid, which opens the valves when the unit is in service and closes the valves when the unit is in regeneration or standby. For 2", and 2½" SFKs the valves shall be DM200, or DM250 125 psi cast iron diaphragm valves with Buna Seats. For the 3", 4" and 6" SFKs the valves shall be DM300B, DM400B, or DM600B grooved end, polyester coated and lined, 235 psi cast iron diaphragm valves.

Shut Off Bypass Kit on MF 1 ½" Systems (-S). For a 1 ½" SBK a single cast iron diaphragm valve with Buna Seats shall be installed on the outlet. This SBK only bypasses the outlet. The inlet shall flow through the Taskmaster III™.

Simplex (-SX). Simplex systems shall have regeneration initiated by time of day or "clock time". SX systems shall have one brine tank, one Taskmaster III™ control valve, one ERCt controller. Ordering an optional shut off kit will prevent hard water bypass.

Simplex Meter Systems (-SM). Simplex metered systems shall have regeneration initiated by gallons treated (demand). SM systems shall have one brine tank, one Taskmaster III™ control valve, one ERCd controller, one PW, PWS or TM series flow meter. and two shut off kits (one for each vessel). Regeneration initiation and meter display shall be provided by the ERCt. Ordering an optional shut off kit will prevent hard water bypass.

Twin (-T). Twin systems shall consist of two mineral tanks with attached Taskmaster III™ control valves and one brine tank with a brine director. Regeneration initiation shall be by an ERCt time initiated electronic regeneration controller on each unit. Vessels will regenerate on time of day.

Twin Alternating (-TA). Twin alternating units operate so that once a predetermined amount of water has passed through the flow meter the ERCd initiates regeneration of the exhausted unit placing its twin in service. One unit is on line and one is either in standby or service. The ERCd demand initiated regeneration controller controls the regeneration cycles for both of the twin alternating units. TA systems shall have two mineral

tanks, two Taskmaster III™ control valves, one brine tank with brine director, one ERcT controller, one PW, PWS or TM series flow meter and two shut off kits. Regeneration initiation and meter display shall be provided by the ERcT.

System Operating Conditions. Maximum temperature shall be 100°F. Maximum Pressure shall be 100 psi. The pressure rating can be increased to 125 psi by specifying 125 psi vessels. The temperature rating can be raised to 180°F by specifying Viton seals for the shut off kits (-V), high temperature epoxy (placite) for the vessels, and 10% cross-linked resin.

Other items. A standard soft water soap test kit shall be provided. A complete set of instructions, including installation, loading, start-up, adjustments, servicing, and a parts list shall be provided with the equipment.

Qualifications. A company that has continuously manufactured water softeners for at least twenty (20) years shall construct this equipment.

Pressure gauge and test tap kit. A kit containing two liquid filled, stainless steel pressure gauges with 2 ½" Ø face, two brass ball valve sample taps with hose barb connections and associated brass connection fittings shall be provided for mounting in the 1/4" FNPT predrilled and tapped ports in the inlet and outlet of the Task Master II valve.

MF SERIES SPECIFICATION (MF 900S-4 AND MF 1200S- 4 AND –6)

Fitting Configuration for Standard Non Code Vessels for 4" and 6" piping. The inlet and outlet shall be 4 or 6 inch double drilled double tapped flanges mounted on the sideshell of the vessel. Each tank shall have a ¾" top center vent fitting and a 1 ½" bottom drain fitting. A 1 ½" full coupling shall be provided in the side shell for the brine inlet. Vessels larger shall have an 11" x 16" manway in the top and a 12" x 16" manway in the side shell. The vessel shall have 4 lifting lugs and four angle legs.

Brine inlet header. For the MF 1200S- 4 and –6 the external brine eductor shall feed into a SCH 80 PVC header lateral brine distributor.

External Brine Ejector. Brine shall be drawn directly into inlet of the mineral tank using an EE series external ejector. This venturi type device shall be SCH 80 PVC with 1" or 1 ½" FNPT connections. The venturi shall be chemically bonded to the housing. The venturi shall be precision machined. Maximum temperature shall be 140°F. The external injector shall provide both brine flow and brine dilution.

Brine Inlet Valves. Brine shall enter the vessels through a DM100 or DM150 125 psi cast iron diaphragm valves with Buna Seats. A bronze check valve and a bronze ball valve with stainless steel ball shall provide brine line isolation.

SHIPPING WEIGHTS		
Model No.	Single Pounds	Twin* Pounds
150	859	1661
180	912	1767
200	1040	2023
225	1058	2059
240	1111	2165
300	1514	2971
450	1832	3554
600	2427	4689
750	2782	5399
900	3402	6629
1200	5700	10100

MF SERIES DIMENSIONS - INCHES												
Model	A	B	C	D	E	F	G	H	I	J	K	L
MF 150	69 ¼	20	54	24	50	50	76	31¼	57	4x6	4x6	4 ½
MF 180	69 ¼	20	54	24	50	50	76	31¼	57	4x6	4x6	4 ½
MF 240	70 ½	24	54	24	50	54	84	35 ¼	58	4x6	4x6	4 ½
MF 300	81 ¼	30	60	24	50	60	102	41 ¼	66	4x6	4x6	4 ½
MF 450	81 ¼	30	60	30	60	74	110	41 ¼	66	4x6	4x6	4 ½
MF 600	82 ½	36	60	38	60	80	122	47 ¼	66	11X15	4X6	4 ½
MF 750	82 ½	36	72	38	60	84	126	47 ¼	66	11X15	4X6	4 ½
MF 900	98 ½	42	72	42	60	90	138	59	66	11X15	4X6	4 ½
MF 1200	106	48	72	50	60	108	168	64	66	12X16	11X15	4 ½

MF SERIES DIMENSIONS - CENTIMETERS												
Model	A	B	C	D	E	F	G	H	I	J	K	L
MF 150	175.9	50.8	137.2	61.0	127.0	127.0	193.0	79.4	144.8	10.2x15.2	10.2x15.2	11.4
MF 180	175.9	50.8	137.2	61.0	127.0	127.0	193.0	79.4	144.8	10.2x15.2	10.2x15.2	11.4
MF 240	179.1	61.0	137.2	61.0	127.0	137.2	213.4	89.5	147.3	10.2x15.2	10.2x15.2	11.4
MF 300	206.4	76.2	152.4	61.0	127.0	167.6	259.1	104.8	167.6	10.2x15.2	10.2x15.2	11.4
MF 450	206.4	76.2	152.4	76.2	152.4	188.0	279.4	104.8	167.6	10.2x15.2	10.2x15.2	11.4
MF 600	209.6	91.4	152.4	96.6	152.4	203.2	309.4	120.0	167.6	27.9X38.1	10.2X15.2	11.4
MF 750	209.6	91.4	182.9	96.6	152.4	213.2	320.0	120.0	167.6	27.9X38.1	10.2X15.2	11.4
MF 900	250.2	106.7	182.9	106.7	152.4	228.6	350.5	149.9	167.6	27.9X38.1	10.2X15.2	11.4
MF 1200	269.2	121.9	182.9	127.0	152.4	274.3	426.7	162.6	167.6	30.5X40.6	27.9X38.1	11.4

NOTE:
 A – HEIGHT⁵,
 H – DEPTH,
 F – SINGLE WIDTH,
 G – TWIN WIDTH⁶
 SPECIFICATIONS LISTED
 ARE NOT SKID MOUNTED
 SYSTEMS.
 SKID DIMENSIONS GIVEN
 UPON REQUEST.

