

Drain Valves

Model 793 Part No. 401500, 150 psig (10.3 bar)
Part No. 401503, 250 psig (17.3 bar)

Drain Valve

- Automatically removes water from compressed air tanks, air separators and after-coolers
- Minimum air loss
- ½" NPT outlet, ½" NPT side inlet, ¾" NPT top inlet
- Cast iron body and cover, stainless steel interior
- Maximum pressure 250 psig (17.3 bar)
- Maximum hydrostatic pressure 350 psig (24.2 bar)

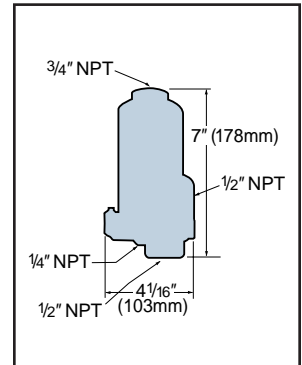

CAPACITY:

Discharge Orifice

- for operating pressures up to 150 psig (10.3 bar), 3/32" (2.4mm) seat
- for operating pressures over 150 psig (10.3 bar), 5/64" (2mm) seat

Model 793 Capacity			
Pressure psig (bar)	lbs. of water/hr. (kg of water/hr)		
	3/32" (2.4mm) Orifice	5/64" (2mm) Orifice	
250 (17.3)	—	900 (408)	
200 (13.8)	—	800 (360)	
150 (10.3)	1200 (545)	690 (315)	
125 (8.6)	1100 (500)	630 (285)	
100 (6.9)	975 (442)	570 (258)	
80 (5.5)	870 (394)	510 (231)	
50 (3.5)	690 (312)	400 (181)	
30 (2.1)	530 (240)	315 (143)	
15 (1.0)	375 (170)	220 (100)	

Model 656A Part No. 400805

Thermodisc Drain Valve

- Automatically removes water from compressed air tanks, air separators and after-coolers
- Freeze protection
- Replaceable disc and seat for easy service
- Only one moving part—reduces wear
- Capacities to 1400 lbs./hr. (635 kg/hr.)
- Maximum temperature 750°F (399°C)
- Maximum pressure 600 psig (41.4 bar)
- ½" NPT

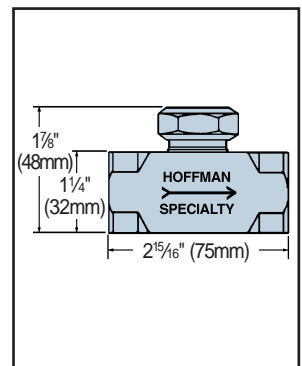

For Compressed Air Service

Pressure psig (bar)	½" NPT 656A lbs./hr. (kg/hr.)
250 (17.3)	1400 (635)
200 (13.8)	1280 (580)
150 (10.3)	1160 (525)
125 (8.6)	1085 (490)
100 (6.9)	975 (440)
75 (5.2)	880 (400)
50 (3.4)	720 (325)
15 (1.0)	380 (170)