

## STEAM TRAPS

## WT4000

## Thermostatic Steam Trap (Repairable)

Watson McDaniel reserves the right to change the designs and/or materials of its products without notice.  
©2006 Watson McDaniel Company

Model	WT4000
Sizes	3/4", 1"
Connections	NPT, SW, FLG
Body Material	Stainless Steel
Options	Strainer, Blowdown Valve
PMO Max. Operating Pressure	300 PSIG
TMO Max. Operating Temperature	Saturated Steam Temperature
PMA Max. Allowable Pressure	906 PSIG @ 100°F
TMA Max. Allowable Temperature	750°F @ 725 PSIG



## TYPICAL APPLICATIONS

**PROCESS** The WT4000 thermostatic steam trap is used for industrial process applications. Their compact size, all stainless steel construction, excellent air handling capability and wide operating pressure range make them a great choice for most process applications. Thermostatic traps are far superior to bucket traps and thermodynamic disc traps in their ability to remove air from the system.

## HOW IT WORKS

The thermostatic trap contains a welded stainless steel thermal element that expands when heated and contracts when cooled. When air and condensate are present, the trap is in the open discharge position. When steam reaches the trap, the element expands and closes off tightly.

## FEATURES

- The thermal element and seat can be easily removed and replaced in minutes with the trap body still in-line
- Operates at steam pressures up to 300 PSIG
- Thermostatic traps have excellent air handling capability allowing air to be discharged rapidly and steam to enter the system quickly during start up
- Welded stainless steel thermal element that resists shock from water hammer
- Freezeproof when the trap is installed in a vertical orientation allowing for complete condensate drainage
- Body is produced from stainless steel investment casting
- Hardened stainless steel seat for extended service life
- Available with integral strainer and blowdown

## SAMPLE SPECIFICATION

The steam trap shall be of thermostatic type with stainless steel body, thermal element, and internal strainer. Trap must be in-line repairable with a bolt on type cover that is sealed with a spiral wound Stainless steel AISI 316 gasket. Seat and disc to be hardened stainless steel.

## INSTALLATION

Isolation valves should be installed with trap. Trap can be installed in any position.

## MAINTENANCE

If trap fails, remove cover and replace the internal working components. Repair kit includes thermal element, seat and gasket. For full maintenance details see Installation and Maintenance Manual.

## OPTIONS

Strainer, blowdown valve, and steam lock release.

**S** = Strainer

**SB** = Strainer and blowdown Valve

Customized flanged connections: Specify size, face to face dimensions and metallurgy required for application.

## MATERIALS

Body	Stainless Steel, AISI 316L
Cover	Stainless Steel, AISI 316L
Cover Gasket	Spiral Wound Stainless Steel, AISI 316
Cover Bolts	Steel, ASTM A193 GR B7 Nickel Plated
Thermal Element	Stainless Steel, AISI 302
Valve & Seat	Hardened Stainless Steel, AISI 416
Seat Gasket	Stainless Steel, AISI 316
Screen*	0.046 Perforated Stainless Steel AISI 304
Blowdown Valve*	Stainless Steel AISI 300

\*Screen and blowdown valve are optional

## HOW TO ORDER

Refer to the capacity chart to determine which model is required to satisfy the condensate load.

Add **S** to the end of the model code if a strainer is required.

Add **B** to the end of the model code if a blowdown valve is required.

**7/16"** orifice is standard and will be supplied if not specified. Specify orifice size **5/16"** or **7/16"**.

Example:

**3/4" WT4000S 7/16" orifice**      3/4" connection with strainer

**1" WT4000SB 5/16" orifice**      1" connections with strainer and blowdown valve

## WT4000

### Thermostatic Steam Trap

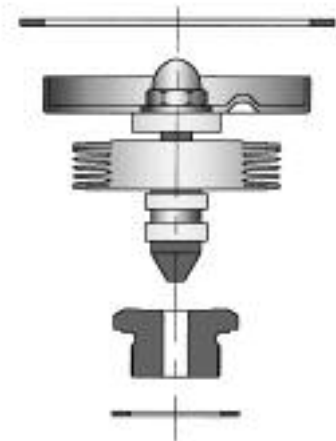
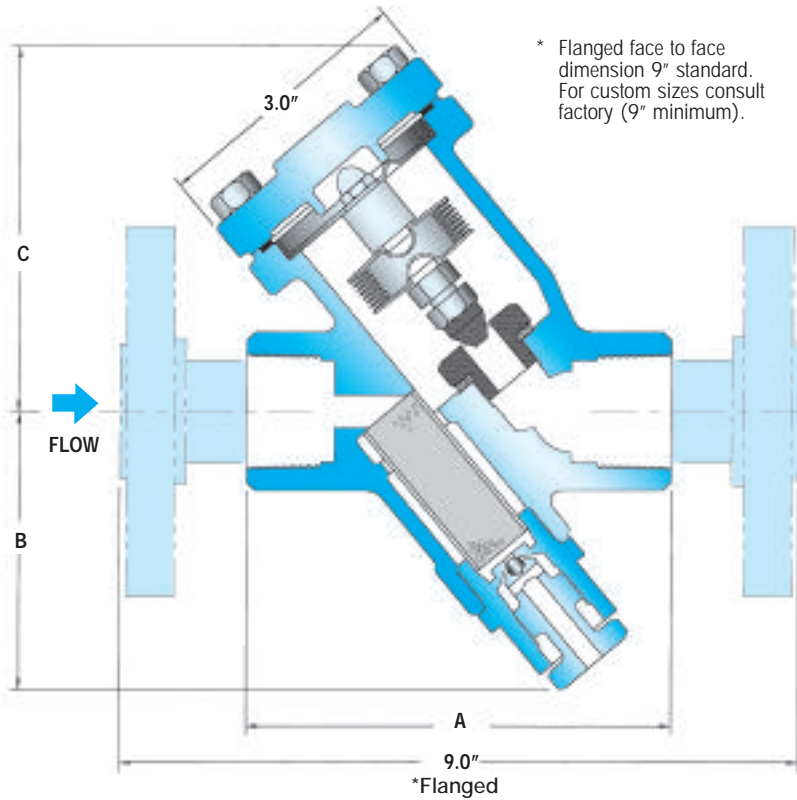

Internals

#### DIMENSIONS & WEIGHTS – inches/pounds

Size/Model	Connection	A	B	C	Weight (lbs)
<b>Series WT4000, WT4000S (Strainer)</b>					
3/4"	NPT, SW	4.5	2.57	4.12	4.5
1"	NPT, SW	4.5	2.57	4.12	4.5
<b>Series WT4000SB, (Strainer &amp; Blowdown Valve)</b>					
3/4"	NPT, SW	4.5	3.12	4.12	4.5
1"	NPT, SW	4.5	3.12	4.12	4.5

#### CAPACITIES – Condensate (lbs/hr)

Model	Pipe Size	Orifice Size	Steam Inlet Pressure (PSIG)											
			1	2	5	10	20	50	100	125	150	200	250	300
WT4000	3/4", 1"	5/16"	605	855	1350	1910	2705	4275	5610	6045	6425	7070	7615	8095
WT4000S		7/16"	940	1325	2095	2960	4190	6620	8695	9365	9950	10955	11800	12540
WT4000SB														

Back Pressure as Percentage of Inlet Pressure	10	20	25	30	40	50	60	70	80	90
Percent Decrease in Trap Capacity	0	0	0	2	5	12	20	30	40	55

Notes: 7/16" orifice size is standard and is normally used on process equipment.  
5/16" orifice size is offered for reduced capacity.