

NOTICE TO INSTALLER: Instructions must remain with installation.

SECTION: 6.10.030

"QUALITY PUMPS SINCE 1939"

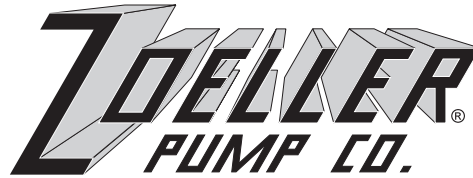

FM2211

1017

Supersedes

0605

Product information presented here reflects conditions at time of publication. Consult factory regarding discrepancies or inconsistencies.



MAIL TO: P.O. BOX 16347 • Louisville, KY 40256-0347
SHIP TO: 3649 Cane Run Road • Louisville, KY 40211-1961
(502) 778-2731 • 1 (800) 928-PUMP • FAX (502) 774-3624

visit our web site: www.zoeller.com

OWNER'S MANUAL



X600 HAZARDOUS ENVIRONMENT SERIES CLASS 1, DIVISION 1, GROUP C & D SUBMERSIBLE SOLIDS HANDLING PUMPS

Congratulations on the purchase of the Zoeller X600 Series submersible pump. This pump has been constructed in compliance with FM and CSA testing. These requirements enable the unit to be listed as an explosion proof pump rated for use in Class 1, Division 1, Group C & D environments.

This manual incorporates the installation, operation, maintenance, and service instructions into one document to aid in the ownership of a Zoeller submersible solids handling product. Please read and review this manual before installing the product.

Table of Contents

Safety Instructions 1
Limited Warranty 2
Performance Data 2
Preinstallation Information 3
Electrical Data 3
Typical Dewatering Installation 4
Typical Sewage Installation 4
Pump Wiring Instructions 5-6
Operation 6-7
Maintenance 7
Service Checklist 8

Owner's Information

Model Number: _____ Date Code: _____
Serial Number: Pump 1 _____ Pump 2 _____
Simplex Panel P/N
Duplex Rail System P/N
Job Name: _____
Distributor: _____
Sales Order Number: _____
Contractor: _____
Date of Installation: _____
System Readings During Operation: Voltage _____ Amps _____

Safety Instructions

TO AVOID SERIOUS OR FATAL PERSONAL INJURY OR MAJOR PROPERTY DAMAGE, READ AND FOLLOW ALL SAFETY INSTRUCTIONS IN THIS MANUAL AND ON THE PUMP.

THIS MANUAL IS INTENDED TO ASSIST IN THE INSTALLATION AND OPERATION OF THIS UNIT AND MUST BE KEPT WITH THE PUMP.



This is a SAFETY ALERT SYMBOL. When you see this symbol on the pump or in the manual, look for one of the following signal words and be alert to the potential for personal injury or property damage.

- ▲ DANGER Warns of hazards that WILL cause serious personal injury, death or major property damage.
▲ WARNING Warns of hazards that CAN cause serious personal injury, death or major property damage.
▲ CAUTION Warns of hazards that CAN cause personal injury or property damage.
▲ NOTICE INDICATES SPECIAL INSTRUCTIONS WHICH ARE VERY IMPORTANT AND MUST BE FOLLOWED.

THOROUGHLY REVIEW ALL INSTRUCTIONS AND WARNINGS PRIOR TO PERFORMING ANY WORK ON THIS PUMP.

MAINTAIN ALL SAFETY DECALS.

REFER TO WARRANTY ON PAGE 2.

Limited Warranty

Manufacturer warrants, to the purchaser and subsequent owner during the warranty period, every new product to be free from defects in material and workmanship under normal use and service, when properly used and maintained, for a period of one year from date of purchase by the end user, or 18 months from date of original manufacture of the product, whichever comes first. Parts that fail within the warranty period, one year from date of purchase by the end user, or 18 months from the date of original manufacture of the product, whichever comes first, that inspections determine to be defective in material or workmanship, will be repaired, replaced or remanufactured at Manufacturer's option, provided however, that by so doing we will not be obligated to replace an entire assembly, the entire mechanism or the complete unit. No allowance will be made for shipping charges, damages, labor or other charges that may occur due to product failure, repair or replacement.

This warranty does not apply to and there shall be no warranty for any material or product that has been disassembled without prior approval of Manufacturer, subjected to misuse, misapplication, neglect, alteration, accident or act of God; that has not been installed, operated or maintained in accordance with Manufacturer's installation instructions; that has been exposed to outside substances including but not limited to the following: sand, gravel, cement, mud, tar, hydrocarbons, hydrocarbon derivatives (oil, gasoline, solvents, etc.), or other abrasive or corrosive substances, wash towels or feminine sanitary products,

etc. in all pumping applications. The warranty set out in the paragraph above is in lieu of all other warranties expressed or implied; and we do not authorize any representative or other person to assume for us any other liability in connection with our products.

Contact Manufacturer at, 3649 Cane Run Road, Louisville, Kentucky 40211, Attention: Customer Service Department to obtain any needed repair or replacement of part(s) or additional information pertaining to our warranty.

MANUFACTURER EXPRESSLY DISCLAIMS LIABILITY FOR SPECIAL, CONSEQUENTIAL OR INCIDENTAL DAMAGES OR BREACH OF EXPRESSED OR IMPLIED WARRANTY; AND ANY IMPLIED WARRANTY OF FITNESS FOR A PARTICULAR PURPOSE AND OF MERCHANTABILITY SHALL BE LIMITED TO THE DURATION OF THE EXPRESSED WARRANTY.

Some states do not allow limitations on the duration of an implied warranty, so the above limitation may not apply to you. Some states do not allow the exclusion or limitation of incidental or consequential damages, so the above limitation or exclusion may not apply to you.

This warranty gives you specific legal rights and you may also have other rights which vary from state to state.

Each Zoeller X600 Series Pump installation is required to have a completed Zoeller Pump Company Start-up Report (FM0990). The report is to be completed by an approved Start-up Technician in the presence of the installing contractor. A copy of this report will be on file at the Zoeller Pump Company offices in Louisville, KY. **Failure to comply with the requirement will void the warranty agreement.**

Performance Data

MODEL		X611		X621		X631	
Feet	Meters	Gal.	Liters	Gal.	Liters	Gal.	Liters
5	1.5	255	965	340	1287	385	1457
10	3.0	190	719	277	1048	330	1249
15	4.6	110	416	215	813	275	1040
20	6.1	35	132	143	541	220	832
25	7.6	--	--	72	272	150	567
30	9.1	--	--	--	--	80	302
35	10.7	--	--	--	--	--	--
40	12.2	--	--	--	--	--	--
45	13.7	--	--	--	--	--	--
50	15.2	--	--	--	--	--	--
55	16.7	--	--	--	--	--	--
60	18.2	--	--	--	--	--	--
Shut-off Head:		22 ft.(6.7m)		29 ft.(8.8m)		35 ft.(10.7m)	

013859B

MODEL		X641		X651		X661	
Feet	Meters	Gal.	Liters	Gal.	Liters	Gal.	Liters
5	1.5	480	1816	575	2176	--	--
10	3.0	430	1627	533	2017	600	2271
15	4.6	380	1438	490	1854	560	2119
20	6.1	325	1230	440	1665	515	1949
25	7.6	270	1022	390	1476	475	1798
30	9.1	208	787	335	1268	430	1627
35	10.7	143	541	280	1059	383	1449
40	12.2	72	272	220	832	330	1249
45	13.7	--	--	150	568	280	1059
50	15.2	--	--	80	302	220	832
55	16.7	--	--	--	--	150	568
60	18.2	--	--	--	--	85	321
Shut-off Head:		44 ft.(13.4m)		55 ft.(16.8m)		65 ft.(19.8m)	

013859C

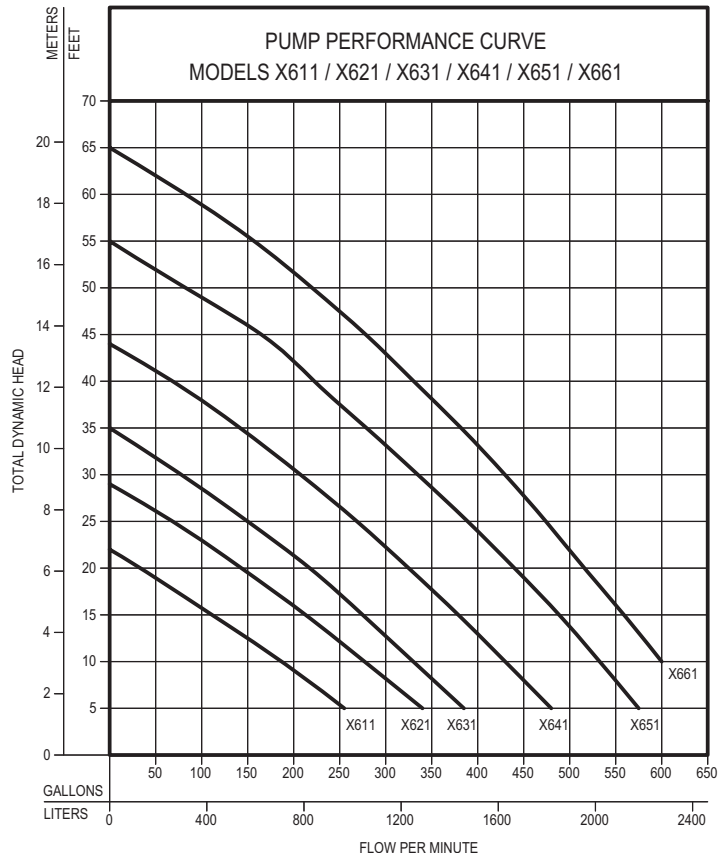

013859A

Preinstallation Information

1. **Inspect your pump.** Occasionally, products are damaged during shipment. If the unit is damaged, contact your distributor before using. **DO NOT** remove the test plugs in the cover nor the motor housing.
2. **Carefully read the literature** provided to familiarize yourself with specific details regarding installation and use. These materials should be retained for future reference.
3. **National Electrical Code (NEC) articles 500 through 503 explain in detail the requirements for the installation and wiring of electrical equipment in hazardous locations.**



⚠ WARNING

SEE BELOW FOR LIST OF WARNINGS



⚠ CAUTION

SEE BELOW FOR LIST OF CAUTIONS

1. Not for use in acidic atmospheres.
2. Do not lift, carry, or hang pump by the electrical cables. Damage to the electrical cables can cause shock, burns or death.
3. **Make sure there is a properly grounded connection available.** All pumps are furnished with provisions for proper grounding to help protect you against the possibility of electrical shock.
4. Make certain that the control box is within the reach of the pump's power supply cord. **DO NOT USE AN EXTENSION CORD.** Extension cords that are too long or too light do not deliver sufficient voltage to the pump motor. But, more important, they could present a safety hazard if the insulation were to become damaged or the connection end were to fall into the sump.
5. **Make sure the pump electrical supply circuit is equipped with fuses and disconnect or circuit breakers of proper capacity.** A separate branch circuit is recommended, sized according to the "National Electrical Code" for the current shown on the pump nameplate.
6. Risk of electric shock - These pumps have not been investigated for use in swimming pool areas.
7. According to the state of California (Prop 65), this product contains chemicals known to the state of California to cause cancer and birth defects or other reproductive harm.
8. Electrical wiring and protection **must** be in accordance with the National Electrical Code per NEC articles 500 through 503 for installation in Class 1, Division 1, Group C & D environments, and any other applicable state and local electrical requirements.

NOTE: CSA Certified pumps are certified to CSA Standard C22.2 No. 145.

1. Check to be sure your power source is capable of handling the voltage requirements of the motor, as indicated on the pump nameplate.
2. The float switches must be connected to an intrinsically safe circuit in the control panel. The installation of float switches is the responsibility of the installing party and care should be taken that the tethered float switch will not hang up on the pump apparatus or pit peculiarities and is secured so that the pump will shut off. It is recommended that rigid piping and fittings be used and the pit be 36" or larger in diameter.
3. **INFORMATION - VENT HOLE PURPOSE.** It is necessary that all submersible pumps capable of handling various sizes of solid waste be of the bottom intake design to reduce clogging and seal failures. If a check valve is incorporated in the installation, a vent hole (approx. 3/16") must be drilled in the discharge pipe below the check valve and pit cover to purge the unit of trapped air. Water stream will be visible from this hole during pump run periods. This vent hole should be checked periodically for clogging and cleaned as necessary. Trapped air is caused by agitation and/or a dry basin.
4. Water hammer creates momentary high pressure surges. These surges can cause severe damage to check valves and the piping system. Consideration for water hammer must be included in the piping system design. Reference ASPE Data Book, Chapter 2.33. Some systems may require external spring or lever weighted check valves or other engineered solutions.
5. Three phase pumps must be connected for proper rotation, which is counterclockwise looking into impeller inlet. See page 5 for instructions for checking 3 phase rotation.
6. Care should be taken during the initial installation to be sure that adequate air supply is available whenever any person is in the basin. Always follow OSHA guidelines on confined space requirements.

Electrical Data

Model	BHp	Service Factor	RPM	Voltage	Phase	Hertz	Amps				KVA Code	Winding Resistance Line-to-Line
							Full Load	In Air	Shut Off	Locked Rotor		
EX611	1	1.2	1750	230	1	60	6.9	4.1	4.7	48.0	M	2.5 / 4.8
JX611	1	1.2	1750	200	3	60	4.1	3.3	3.7	32.0	M	2.2
FX611	1	1.2	1750	230	3	60	3.6	2.2	2.6	28.0	M	3
GX611	1	1.2	1750	460	3	60	1.8	1.1	1.3	14.0	M	12
BAX611	1	1.2	1750	575	3	60	1.4	1.0	1.1	11.5	M	18
EX621	1 1/2	1.2	1750	230	1	60	8.9	4.3	5.3	48.0	J	2.5 / 4.8
JX621	1 1/2	1.2	1750	200	3	60	5.8	3.3	3.7	32.0	J	2.2
FX621	1 1/2	1.2	1750	230	3	60	5.1	2.3	2.9	28.0	J	3
GX621	1 1/2	1.2	1750	460	3	60	2.6	1.2	1.5	14.0	J	12
BAX621	1 1/2	1.2	1750	575	3	60	2.0	1.0	1.3	11.5	J	18
EX631	2	1.2	1750	230	1	60	12.0	7.2	8.0	86.0	L	.94/3.8
JX631	2	1.2	1750	200	3	60	7.8	4.5	5.0	46.0	J	1.5
FX631	2	1.2	1750	230	3	60	6.8	2.3	4.4	41.0	K	2
GX631	2	1.2	1750	460	3	60	3.4	1.2	2.2	20.5	K	8
BAX631	2	1.2	1750	575	3	60	2.7	1.4	1.8	16.2	K	12
EX641	3	1.2	1750	230	1	60	17.0	7.2	8.9	86.0	H	.94/3.8
JX641	3	1.2	1750	200	3	60	11.0	4.5	5.6	46.0	F	1.5
FX641	3	1.2	1750	230	3	60	9.6	2.3	4.7	41.0	F	2
GX641	3	1.2	1750	460	3	60	4.8	1.7	2.4	20.5	F	8
BAX641	3	1.2	1750	575	3	60	3.9	1.4	2.0	16.2	F	12
EX651	5	1.2	1750	230	1	60	28.0	16.1	19.7	139.0	H	.9 / 3.1
JX651	5	1.2	1750	200	3	60	17.5	6.1	7.6	64.0	D	1
FX651	5	1.2	1750	230	3	60	15.2	6.1	7.4	58.0	E	1.3
GX651	5	1.2	1750	460	3	60	7.6	3.1	3.7	29.0	E	5.2
BAX651	5	1.2	1750	575	3	60	6.1	1.5	3.4	23.0	E	8.0
JX661	7 1/2	1.0	1750	200	3	60	28.0	17.9	18.3	83.0	C	0.5
FX661	7 1/2	1.0	1750	230	3	60	23.0	15.0	15.7	72.0	C	0.7
GX661	7 1/2	1.0	1750	460	3	60	12.5	7.5	7.9	36.0	C	2.8
BAX661	7 1/2	1.0	1750	575	3	60	9.4	5.3	5.8	29.0	C	5.4

*Consult Factory.

Typical Sewage/Waste Pumping System Installation

All installations must comply with all applicable electrical and plumbing codes, including, but not limited to, National Electrical Code, local, regional, and/or state plumbing codes, etc.

TYPICAL INDOOR FIBERGLASS BASIN

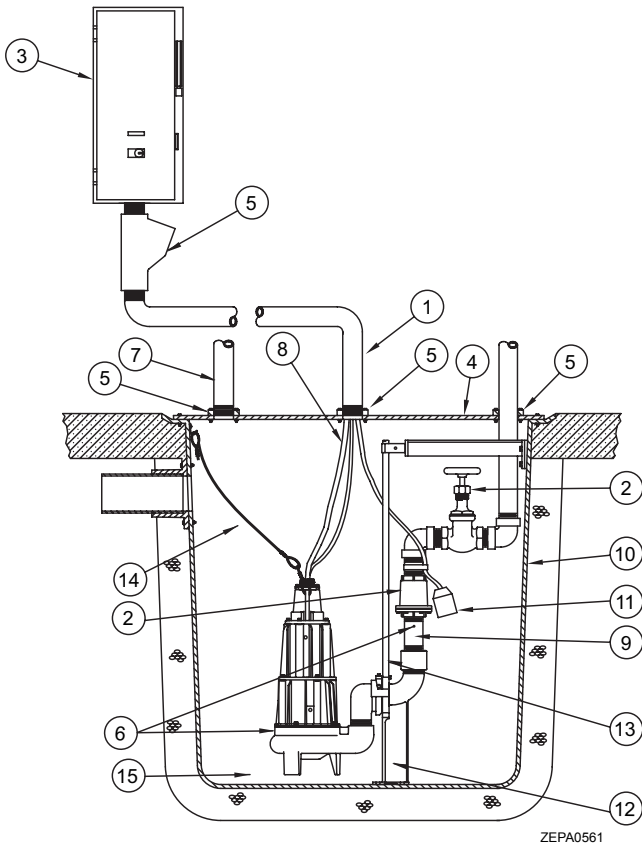

ZEPA0561

TYPICAL OUTDOOR CONCRETE BASIN WITH VALVE BOX AND HINGED ACCESS COVERS

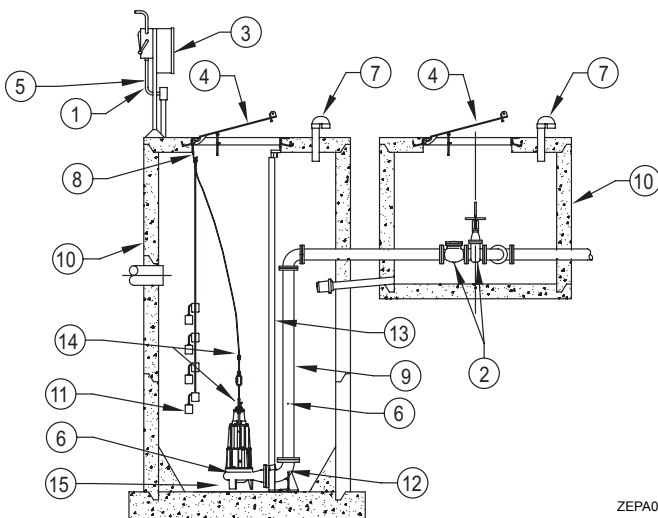
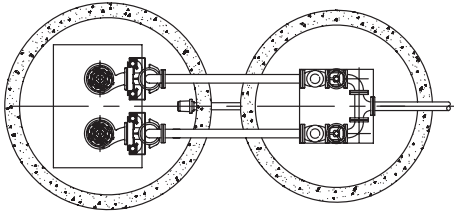

ZEPA0562

- (1) Electrical wiring and protection **must** be in accordance with the National Electrical Code per NEC articles 500 through 503 for installation in Class 1, Division 1, Group C & D environments, and any other applicable state and local electrical requirements.
- (2) Install proper full flow check and shut-off valve.
- (3) Install proper controls. (Outdoor panels in ventilated areas **require** NEMA 3R or 4X enclosure) Float switch connections shall be intrinsically safe.
- (4) All installations **require** a basin cover to prevent debris from falling into the basin and to prevent accidental injury.
- (5) Cords must be properly sealed per NEC articles 500 through 503 for installation in Class 1, Division 1, Group C & D environments, to prevent moisture and gases from entering the control panel.
- (6) **When check valve is installed**, drill a 3/16" diameter hole in the discharge pipe below the check valve even with the top of the pump. NOTE: The hole must be below the basin cover and cleaned periodically. Water stream will be visible from this hole during pump run periods. Also a vent hole is drilled in the pump housing. Be sure that this hole is cleared during any servicing.
- (7) Vent gases and odors to the atmosphere through vent pipe per Local and State codes.
- (8) Secure power cord to avoid entanglement with variable level float switch mechanism.
- (9) **Do not** reduce pump discharge pipe below 3" IPS size.
- (10) Basin **must** be in accordance with all applicable codes and specifications. Basin must be sized to allow a minimum 3 minute lapse time between starts.
- (11) The tethered variable level float switches must be free and not hang up on pump or pit peculiarities. Float switch circuits shall be intrinsically safe.
- (12) **If a rail system is used**, it should be non-sparking. Discharge elbow **must** be firmly anchored to the bottom of basin. In fiberglass basin, the bottom will need to be reinforced if the discharge elbow is used.
- (13) **If a rail system is used**, it should be non-sparking. The guide rails are 3/4" schedule 40 pipe for threaded vertical discharge units and 2" schedule 40 pipe for flanged horizontal discharge units. Brass, stainless steel or galvanized steel is recommended.
- (14) Install ring and cable for lifting pump from pit.
- (15) Basin must be clean and free of debris after installation.

Pump Wiring Instructions



- ▲ WARNING** Installation and checking of electrical circuits and hardware should be performed by a qualified licensed electrician.
- ▲ WARNING** **“Risk of electrical shock”** Do not remove power supply cord and strain relief or connect conduit directly to the pump.
- ▲ CAUTION** Power cords, sensor cords, and float cords all must be sealed to prevent gases from the basin entering the control panel.

INSTRUCTIONS FOR CHECKING ROTATION OF THREE PHASE UNITS

It is very important that these units be connected for proper rotation. Since no rotating parts are visible without removing the pump from the pit, the rotation on 3 phase units should be checked before installation into the pit as follows:

After the proper electrical connections are made, momentarily energize the pump observing the direction of kick back due to starting torque. The rotation is correct if the kick back is in the opposite direction of the rotation arrow. If the rotation is not correct, disconnect power and switch any two power leads. Turn power back on and retest for proper rotation.

SENSOR CABLE

The sensor cable is the smaller cable, which contains 5 wires. The red and orange wires connect to the thermal cut-out circuit and the black and white wires connect to the seal leak probes. The green wire is a ground connection. All 5 wires must terminate in the control panel.

The following should be noted:

- (1) The thermal sensors are normally closed and mounted adjacent to the motor windings. If internal temperatures exceed a maximum limit, the pump will deactivate when the red and orange wires are connected in series to the control coil of the motor starter circuit. The pump is able to restart once the motor cools down. Continued deactivation of this circuit requires the attention from maintenance personnel.
- (2) The black and white seal leak wires are connected to a 330K ohm circuit in the seal cavity, where 2 seal leak probes are housed. An indicator light will activate whenever water is present in the cavity. Whenever the seal leak light is activated, indicating that the lower seal has failed, the pump should be removed and serviced in order to avoid damage to the motor.
- (3) The green wire shall be connected to a ground lug in the panel.

CONTROL PANELS

These pumps require a control panel. The control panel rarely requires an explosion proof rating since it is usually located outside the hazardous area. A motor starter circuit, control circuit, and alarm circuit within the panel are standard features. Outdoor enclosure ratings and alternating relays are often required. Variable level float switches are the most common level sensing device.

The following should be noted:

- (1) Float switch connections must be intrinsically safe.
- (2) Single phase units have externally mounted capacitors and starting relays. Your control panel should have provisions for mounting these starting components.
- (3) The seal failure sensor and thermal sensor protection shall be incorporated into the panel.
- (4) All pumps require overload protection in panel. Use with approved motor control that matches motor input in full load amperes with overload element(s) selected or adjusted in accordance with control instructions.
- (5) Hazardous Location pumps require panels that offer intrinsically safe relays and all other NEC requirements must be followed (See Article 500, 501, 502 & 503 plus any others that apply.)

POWER AND SENSOR CORD, LEAD IDENTIFICATION

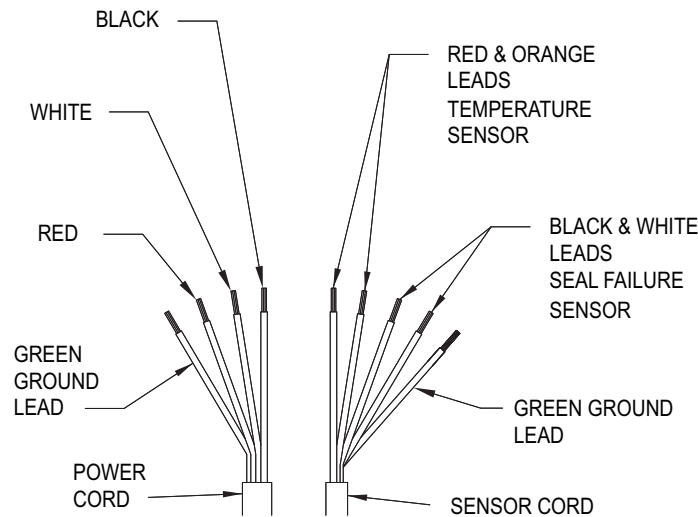

"X600 SERIES" FOUR CONDUCTOR AWG. POWER CORD SIZE						
MODEL	BHP	230/1PH	200/3PH	230/3PH	460/3PH	575/3PH
X611	1	12 AWG.	12 AWG.	12 AWG.	12 AWG.	12 AWG.
X621	1.5	12 AWG.	12 AWG.	12 AWG.	12 AWG.	12 AWG.
X631	2	12 AWG.	12 AWG.	12 AWG.	12 AWG.	12 AWG.
X641	3	12 AWG.	12 AWG.	12 AWG.	12 AWG.	12 AWG.
X651	5	8 AWG.	12 AWG.	12 AWG.	12 AWG.	12 AWG.
X661	7.5	N/A	8 AWG.	8 AWG.	12 AWG.	12 AWG.
APPROXIMATE CORD DIAMETER PER GAUGE						
12/4 AWG.	.64"					
8/4 AWG.	.93"					
NOTE: SENSOR CORD 18/5 AWG. APPROXIMATELY .44" DIAMETER.						

ZEPA0039E

Single Phase Installation

All single phase models require start capacitor, run capacitor and relay in the circuit to start and operate properly. These components can be purchased separately or prewired in Zoeller control panel. For components purchased separately used the diagram for installation and hookup. Single phase models are nonautomatic. To operate automatically a control panel must be added to the power circuit. Follow the instructions provided with the panel.

WIRING DIAGRAM

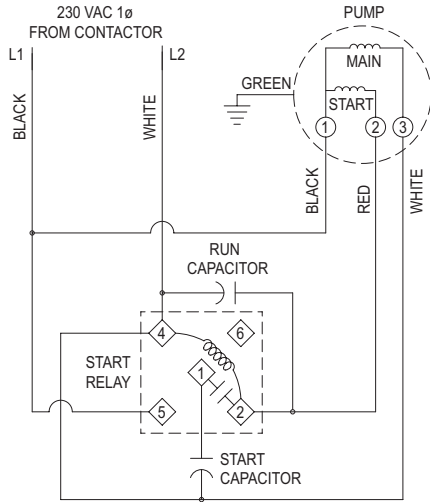

MODELS
X611 / X621

COMPONENT LAYOUT

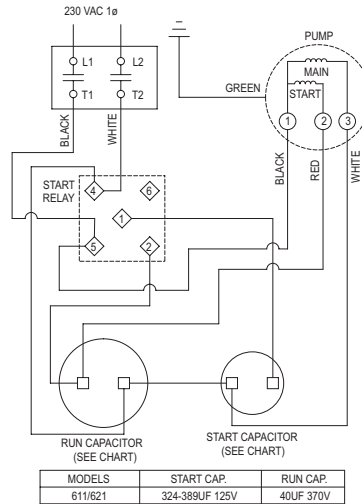

ZEPA0539

ZEPA0477B

WIRING DIAGRAM

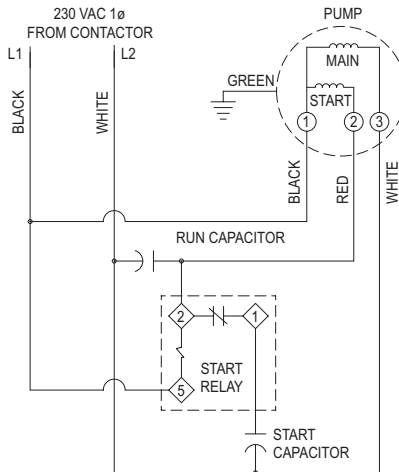

MODELS
X631 / X641 / X651

COMPONENT LAYOUT

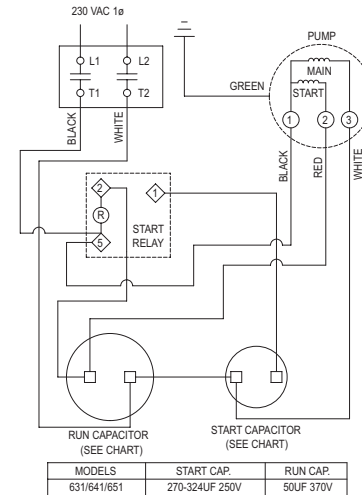

ZEPA0540

ZEPA0537B

Three Phase Installation

Three phase pumps are nonautomatic. To operate automatically, a control panel with level control is required. Follow the instructions provided with the panel to wire the system.

Before installing a pump, check the pump rotation to insure that wiring has been connected properly to power source, and that the green lead of power cord (See wiring diagram), is connected to a valid ground. Momentarily energize the pump, observing the directions of kick back due to starting torque. Rotation is correct if kick back is in the opposite direction of rotation arrow on the pump casing. If rotation is not correct, switching of any two power leads other than ground, should provide the proper rotation.

Refer to the wiring diagram supplied with specific electrical control panel for correct electrical cable termination locations.

TYPICAL 3-PHASE WIRING DIAGRAM

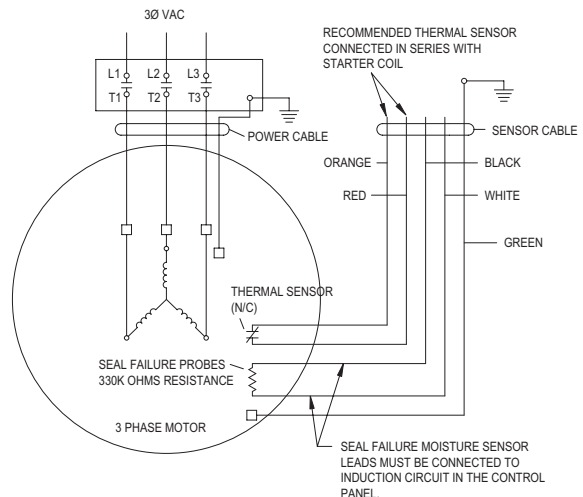

NOTE 1: Sensor cable includes 5 leads; 2 leads for thermal sensor, 2 leads for moisture sensor, and a green ground lead. Sensor wire colors are as shown.

ZEPA0038G

Operation

GENERAL

Zoeller pumps are lubricated and tested at the factory prior to shipment and require minimum pre-start-up maintenance.

Maximum liquid temperature of a continuous operating pump liquid for this model pump must not exceed 104°F (40°C). For longest service life all pumps should be totally submerged on long pumping cycles. Maximum submerged depth is 50'.

These units are not designed to handle liquids other than water or sewage. If pump is used in water contaminated with heavy, viscous, or abrasive materials, the warranty will be voided.

NAMEPLATE DATA

The nameplate, located on the top of pump, indicates specific information about the construction of the pump. The model number, date code, and serial number information should be recorded on the front page in the "Owner's Information" section of this manual.



▲ WARNING

If the pump is repaired in the field, its explosion proof rating may be voided.

SHORT TERM STORAGE

If pump is to be stored, the following is advised:

- Store pump inside whenever possible or cover with some type of protective covering.
- Tape or seal in plastic bag the terminal ends of wire leads.
- Spray coat unpainted surfaces with rust inhibiting oil.
- The impeller should be rotated every six months in order to keep the seals lubricated and not develop a permanent set.

If panel is to be stored, the following is advised:

- Store the panel inside whenever possible and leave in the shipping box.
- All openings shall be sealed.
- Store in an upright position.
- Do not stack anything on top of panel.

START-UP PROCEDURE

Before placing the equipment into operation the following should be checked:

- Correct pump rotation (3 Phase units only).
- Clean pit.
- Panel dry, securely installed and properly sealed.
- Floats positioned properly.
- Discharge valves open.
- 3/16" vent hole drilled in pipe between check valve and pump.

Once the above has been verified proceed with the following checks:

- Pump power cables properly connected to panel.
- Float cables properly connected in an intrinsically safe panel.
- Conduit connections to panel are properly sealed.
- Thermal overload adjustments made in the panel.
- After installing the pump into the containment area, with adequate submergence, open the discharge valve fully. Start the unit using manual controls. If flow is appreciably less than rated performance, pump may be air locked. To expel trapped air, jog the unit several times, using the manual controls.
- Have a qualified electrician take voltage and current measurements on the black wire of single phase or all three power wires of three phase with the pump running. Record these readings in the space provided in the "Owner's Information" section on page 1 of this manual for future reference.

After the preoperational functional test has been completed, system is ready for operation. Zoeller requires completing a Start-up Report (ZM1074) whenever a system is started for the first time or after a system has had a significant change take place (i.e. pump replacement, overhaul, etc.). A copy of the Start-up Report should remain with the system for future reference.

ADJUSTMENT PROCEDURE

- Pumps: No adjustments are required other than assuring correct rotation.
- Panels: The thermal overloads in the panel must be set to the F.L.A. rating on the pump nameplate (or refer to pump data sheet).
- Floats: Refer to the system drawing for desired location of each float function.
- Valves: Discharge valves should be placed in the fully open position. Systems should not be operated for extended periods of time with the discharge valves partially closed due to damaging the valve.

SHUTDOWN PROCEDURES

If a system is shutdown for more than six months, the following is recommended:

- Pumps: If pit is to remain dry, then the pump can remain in the pit. With the pump in the pit, it should be operated for five minutes once every three months. If the pit is to remain wet, the pump should be removed and stored as noted above.
- Panels: The panel should have all openings sealed to prevent moisture and dust from entering the enclosure. Prior to restarting system, the panel should be inspected for presence of moisture and any loose connections.
- Valves: Consult the valve/actuator supplier for information concerning these systems components.

Maintenance

▲ NOTICE Repair and service must be performed by a firm approved by Zoeller Company. The firm must be certified to work on explosion proof motors if motor housing, adapter or cord cap is repaired. Contact Zoeller Technical Service Department regarding warranty issues.

▲ NOTICE If repair to the motor housing, adapter or cord cap is disassembled or repaired by a firm not certified to work on explosion proof motors, the explosion proof rating is void and the FM approval tag **MUST BE REMOVED FROM THE PUMP.**

SAFETY PROCEDURES

▲ WARNING For your protection, always disconnect pump and panel from its power source before handling.

▲ WARNING Never enter the basin until it has been properly vented and tested. Any person entering a basin should be wearing a harness with safety rope extending to the surface so that they can be pulled out in case of asphyxiation. Sewage water gives off methane and hydrogen sulfide gases, both of which can be highly poisonous.

Installation and checking of electrical circuits and hardware should be performed by a qualified electrician.

Pump is never to be lifted by power cord.

▲ WARNING Unit must be flushed and disinfected, inside and out, prior to servicing.

GENERAL SYSTEM INSPECTION

Before the system is placed into operation, a system Start-up Report should be conducted by a qualified technician.

▲ WARNING Wiring and grounding must be in accordance with the national electrical code and all applicable local codes and ordinances.

LUBRICATION PROCEDURES

No lubrication is required.

If pumps are to be stored for more than six months, refer to short term storage procedure in the Operation section.

PREVENTIVE MAINTENANCE

Preventive maintenance is recommended to ensure a long service life from the product. Provided is a suggested maintenance schedule.

Every month:

- Check for proper and unobstructed float operation.
- Listen for proper check valve operation.
- Duplex Units - Check for even operating times. Uneven times indicate a defective unit, float switch or control.
- Inspect the panel for any presence of moisture in enclosure, loose connections, and general component condition. check out location and condition of float switches.

Every year:

- In addition to the monthly checks, the basin should be inspected and cleaned. Any defective components should be replaced. Inspect and remove any sand, debris, or mud present in the pump basin assembly.

Every two years:

- Inspect power cables for damage or wear. Replace immediately if damage or wear is detected.
- Inspect impeller for damage or wear. Replace as required by a Zoeller Authorized Service Station.

DOUBLE SEAL PUMPS

- Double seal pumps offer extra protection. During every inspection of the unit, check the control panel seal failure for a warning. Whenever the seal leak is activated, indicating that the lower seal has failed, the pump should be removed and serviced in order to avoid damage to the motor.

Service Checklist & Trouble Shooting



⚠ WARNING ELECTRICAL PRECAUTIONS Before servicing a pump, always shut off the main power breaker to the panel and then disconnect the pump - making sure you are wearing insulated protective sole shoes and are not standing in water. Under flooded conditions, contact your local electric company or a qualified licensed electrician for disconnecting electrical service prior to pump removal.

CONDITION

A. Pump will not start or run.

Steps	Check Voltage At	If No Voltage	If Voltage
No. 1	Line terminals in pump's control panel L1 - L2 - L3 (3 Phase)	Check Disconnect switch, line fuse, and/or circuit breakers in power supply circuit.	Proceed to No. 2
No. 2	Pump motor terminals in pump's control panel T1 - T2 - T3	Check for control circuit voltage. Check out magnetic starter contacts, thermal overloads, and float switches	Check starting relay and capacitor (1 phase units). Check pump for ground, and binding impeller

B. Motor overheats and trips overload or blows fuse.

COMMON CAUSES

- Incorrect Voltage
- Unbalanced power source
- Incorrect motor rotation
- Negative or low head
- Excessive water temperature
- Impeller or seal mechanically bound
- Defective capacitor or relay
- Motor shorted
- Lost one line in a Three Phase unit

C. Pumps starts and stops too often.

- Check valve stuck open
- Level controls out of adjustment
- Thermal overload switch out of adjustment or defective
- Pit too small

D. Pump will not shut off.

- Debris under float switch
- Float travel obstructed
- Defective or damaged float switch
- Magnetic starter contacts shorted
- Air lock - check vent hole

E. Pump operates but delivers little or no water.

- Check for plugged Pump housing, discharge pipe or sticking check valve
- Vent hole clogged or not drilled
- Discharge head exceeds pumps capacity
- Low or incorrect voltage
- Incorrect motor rotation
- Defective capacitor

F. Drop in head and/or capacity after a period or use.

- Increase Pipe Friction
- Clogged line or check valve
- Abrasive material & chemical, deteriorated impeller and pump housing

If the above check list does not uncover the problem, consult the factory - Do not attempt to service or otherwise disassemble pump.