

Product information presented here reflects conditions at time of publication. Consult factory regarding discrepancies or inconsistencies.

MAIL TO: P.O. BOX 16347 • Louisville, KY 40256-0347
SHIP TO: 3649 Cane Run Road • Louisville, KY 40211-1961
(502) 778-2731 • 1 (800) 928-PUMP • FAX (502) 774-3624

visit our web site:
<http://www.zoeller.com>

"SPECIAL OPTIONS DRAIN PUMP"
2" INLET DRAIN PUMP 105-0010
HIGH HEAD DRAIN PUMP 135-0005

Removes water from areas where gravity flow is not available.

Applications include, laundry tray pump, wet bar sink, lavatory, air conditioning condensate or dehumidifier water removal. It can also be used in conjunction with dishwashers and garbage disposal applications.

Standard Installations

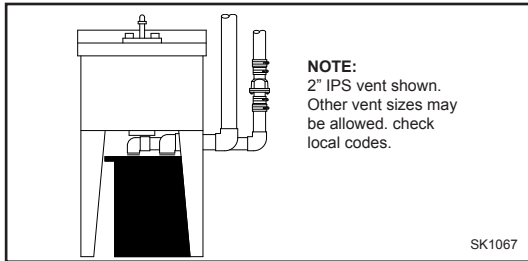

Laundry Tray Pump

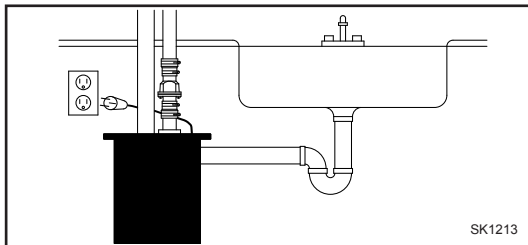

Wet Bar with Sink

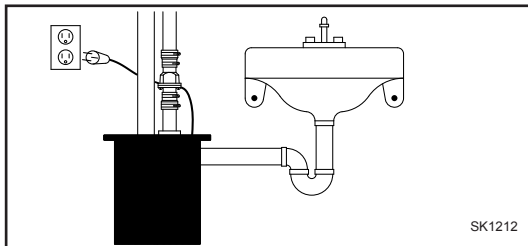

Lavatory Sink

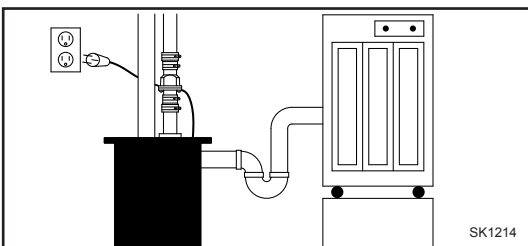

Dehumidifier or Air Conditioner

NO INLET FILTERS OR SCREENS TO CLEAN



Model 105-0010
(2" Inlet)



Model 135-0005
(High Head)

DRAIN PUMP SERIES INCLUDES:

- Automatic pumps with tank cord seals and all hardware for easy assembly.
- Polypropylene basin and lid.
- Internal discharge pipe to lid.
- Check Valve (Model 105 30-0181; Model 135 30-0102).

**DRAIN PUMP
SERIES**

105-0010
135-0005

**MODEL PUMP
WITH BASIN**

M53
WM152

**SHIPPING
WT.**

30 lbs.
48 lbs.

Product may not be exactly as pictured.

COMPARE THESE FEATURES

PUMP FEATURES

105-0010 (Model 53)

- Passes laundry lint.
- Automatic, float operated mechanical switch.
- 115 V/1 Ph, 60 Hz.
- 1550 RPM.
- 9 ft. UL Listed 3-wire cord and plug.
- Stainless steel screws, guard, handle and switch arm.
- Passes 1/2" spherical solids.
- 1 1/2" NPT discharge.
- Non-clogging vortex impeller.
- Glass-filled polypropylene base with built in strainer.
- Temperature rated 130°F (54°C).
- UL Listed Pump.

135-0005 (Model 152)

- Passes laundry lint.
- Durable cast iron construction.
- Corrosion resistant powder coated epoxy finish.
- Stainless steel lifting handle.
- Assembled with stainless steel bolts.
- Non-clogging engineered thermoplastic vortex impeller design.
- Passes 3/4" spherical solids.
- Temperature rated 130°F (54°C).
- Motor - 60 Hz, 3450 RPM, oil filled, hermetically sealed, automatic reset thermal overload protected.
- Carbon/Ceramic seals.
- Upper sleeve bearing and lower ball bearing running in bath of oil.
- .4 HP
- 15 ft. UL Listed power cord with molded 3-wire plug and wired-in vertical float switch.
- 1 1/2" NPT discharge.
- cCSAus certified pump.

BASIN

- Polyethylene construction.
- Corrosion resistant.
- High capacity.
- Gasketed polyethylene lid.
- 2" NPT vent.
- 1 1/2" NPT discharge.
- 2" NPT inlet - no screen.
- Threaded connections for easy installation.
- Height: 15 1/2 inches.
- Width: 15 3/4 inches.
- Weight 5 pounds.
- Gas tight cover.
- Temperature rated 130°F.
- Fits under single or double laundry tray sinks.
- 10' Stack Test Basin.

CHECK VALVE

(30-0181)

- "Full Flow" design.
- 1 1/2" or 1 1/4" slip x slip union.
- PVC construction.

For additional specifications see FM0217.

(30-0102)

- "Full Flow" design.
- 1 1/2" solvent weld.
- PVC construction.

For additional specifications see FM0217.

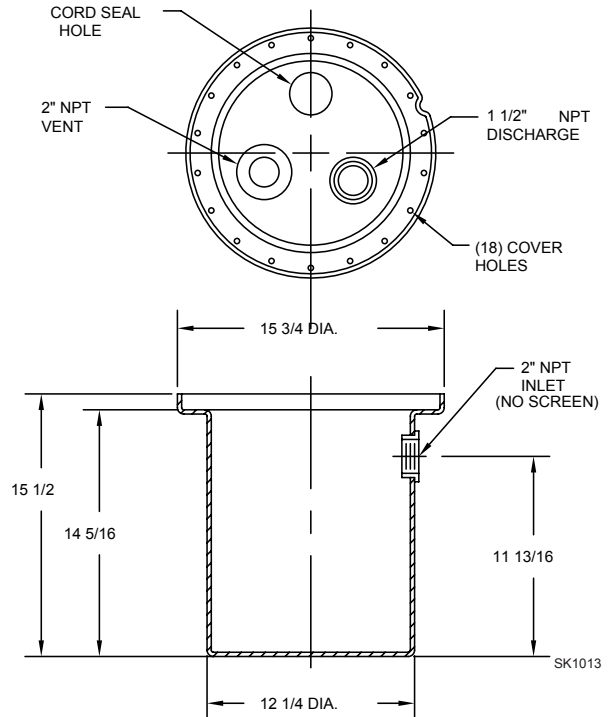

EASY INSTALLATION - NO NEED TO DIG A SUMP.



WARNING TO REDUCE THE RISK OF ELECTRICAL SHOCK A PROPERLY GROUND RECEPTACLE OF GROUNDING TYPE SHALL BE INSTALLED AND PROTECTED BY A GROUND FAULT CIRCUIT INTERRUPTER (GFCI) IN ACCORDANCE WITH NATIONAL ELECTRICAL CODE AND LOCAL CODES. DO NOT REMOVE GROUND PIN FROM PLUG.

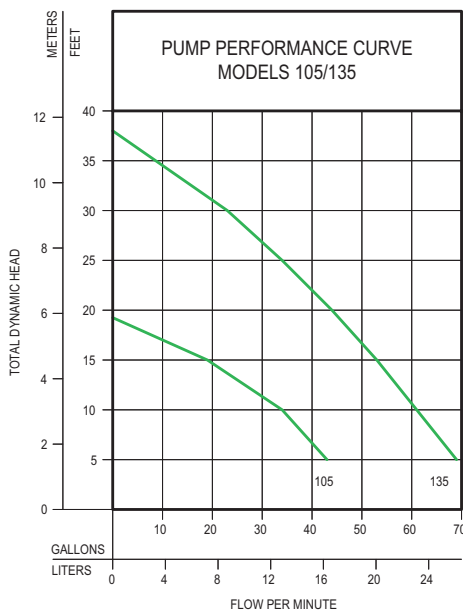

MODEL		105		135	
Feet	Meters	Gal.	Liters	Gal.	Liters
5	1.5	43	163	69	261
10	3.0	34	129	61	231
15	4.6	19	72	53	201
20	6.1	--	--	44	167
25	7.6	--	--	34	129
30	9.1	--	--	23	87
Shut-off Head:		19.25 ft. (5.9m)		38 ft. (11.6m)	

016301B

016301A

Note: Special Option Basin utilizes a different basin than Zoeller's standard system. This basin has a 2" side inlet only.

RESERVE POWERED DESIGN

For unusual conditions a reserve safety factor is engineered into the design of every Zoeller pump.

© Copyright 2003 Zoeller Co. All rights reserved.