

Product information presented here reflects conditions at time of publication. Consult factory regarding discrepancies or inconsistencies.

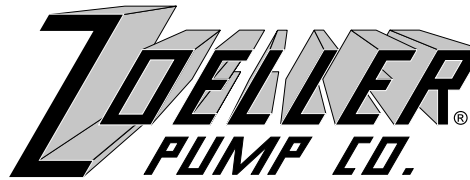

MAIL TO: P.O. BOX 16347 • Louisville, KY 40256-0347  
 SHIP TO: 3649 Cane Run Road • Louisville, KY 40211-1961  
 (502) 778-2731 • 1 (800) 928-PUMP • FAX (502) 774-3624

visit our web site:  
[www.zoeller.com](http://www.zoeller.com)

## INSTALLATION INSTRUCTIONS

### AVAILABLE MODELS HIGH TEMPERATURE PUMPS

SERIES	H.P.	DISCHARGE	SOLIDS	PH	MATERIAL
3098 Series	1/2	1 1/2"	1/2"	1	Cast Iron
3137 Series	1/2	1 1/2"	5/8"	1	Cast Iron
3139 Series	1/2	1 1/2"	5/8"	1	Bronze
3161 Series	1/2	1 1/2" or 2" or 3"	3/4"	1	Cast Iron
3163 Series	1/2	1 1/2" or 2" or 3"	3/4"	1	Cast Iron
3282 Series	1/2	2" or 3"	2"	1	Cast Iron

Nonautomatic (N or E) models with a watertight junction box (for outdoor or above ground installations) are available in all series.

### PREINSTALLATION CHECKLIST - ALL INSTALLATIONS

1. **Inspect your pump.** Occasionally, products are damaged during shipment. If the unit is damaged, contact your dealer before using. **DO NOT** remove the test plugs in the cover nor the motor housing.
2. **Carefully read the literature** provided to familiarize yourself with specific details regarding installation and use. These materials should be retained for future reference.



### WARNING

#### SEE BELOW FOR LIST OF WARNINGS

1. **Make sure there is a properly grounded receptacle available.** All pumps are furnished with provisions for proper grounding to protect you against the possibility of electrical shock.  
(SEE WARNING BELOW)
2. Make certain that the receptacle is within the reach of the pump's power supply cord. **DO NOT USE AN EXTENSION CORD.** Extension cords that are too long or too light do not deliver sufficient voltage to the pump motor. But, more important, they could present a safety hazard if the insulation were to become damaged or the connection end were to fall into the sump.
3. **Make sure the pump electrical supply circuit is equipped with fuses or circuit breakers of proper capacity.** A separate branch circuit is recommended, sized according to the "National Electrical Code" for the current shown on the pump nameplate.
4. **Testing for ground.** As a safety measure, each electrical outlet should be checked for ground using an Underwriters Laboratory Listed circuit analyzer which will indicate if the power, neutral and ground wires are correctly connected to your outlet. If they are not, call a qualified licensed electrician.
5. **For Added Safety.** Pumping and other equipment with a 3-prong grounded plug must be connected to a 3-prong grounded receptacle. For added safety the receptacle may be protected with a ground-fault circuit interrupter. When a pump needs to be connected in a watertight junction box, the plug can be removed and spliced to the supply cable with proper grounding. For added safety this circuit may be protected

- by a ground-fault circuit interrupter. The complete installation must comply with the National Electrical Code and all applicable local codes and ordinances.
6. **FOR YOUR PROTECTION, ALWAYS DISCONNECT PUMP FROM ITS POWER SOURCE BEFORE HANDLING.** Single phase pumps are supplied with a 3-prong grounded plug to help protect you against the possibility of electrical shock. **DO NOT UNDER ANY CIRCUMSTANCES REMOVE THE GROUND PIN.** The 3-prong plug **must** be inserted into a mating 3-prong grounded receptacle. If the installation does not have such a receptacle, it must be changed to the proper type, wired and grounded in accordance with the National Electrical Code and all applicable local codes and ordinances. Pumps **must** be installed in accordance with the National Electrical Code and all applicable local codes and ordinances. Pumps are not to be installed in locations classified as hazardous in accordance with National Electrical Code, ANSI/NFPA 70.
  7. **"Risk of electrical shock"** Do not remove power supply cord and strain relief or connect conduit directly to the pump.
  8. Installation and servicing of electrical circuits and hardware should be performed by a qualified licensed electrician.
  9. Pump installation and servicing should be performed by a qualified person.
  10. Risk of electric shock - These pumps have not been investigated for use in swimming pool and marine areas.
  11. According to the state of California (Prop 65), this product contains chemicals known to the state of California to cause cancer and birth defects or other reproductive harm.

### CAUTION

#### SEE BELOW FOR LIST OF CAUTIONS

1. Check to be certain your power source is capable of handling the voltage requirements of the motor, as indicated on the pump name plate.
2. Check valves used in High Temperature service must be all **metal swing type** check valves.
3. Repair and service should be performed by Zoeller Pump Company Authorized Service Station only.
4. Dewatering and effluent sump pumps are not designed to handle raw sewage.
5. Maximum continuous operating temperature for high temperature pumps must not exceed 200°F - 93°C.
6. Cable from disconnect to control box (consumer furnished) should be rated **105°C**.

REFER TO WARRANTY ON PAGE 2.

# LIMITED WARRANTY

Manufacturer warrants, to the purchaser and subsequent owner during the warranty period, every new product to be free from defects in material and workmanship under normal use and service, when properly used and maintained, for a period of one year from date of purchase by the end user, or 18 months from date of original manufacture of the product, whichever comes first. Parts that fail within the warranty period, one year from date of purchase by the end user, or 18 months from the date of original manufacture of the product, whichever comes first, that inspections determine to be defective in material or workmanship, will be repaired, replaced or remanufactured at Manufacturer's option, provided however, that by so doing we will not be obligated to replace an entire assembly, the entire mechanism or the complete unit. No allowance will be made for shipping charges, damages, labor or other charges that may occur due to product failure, repair or replacement.

This warranty does not apply to and there shall be no warranty for any material or product that has been disassembled without prior approval of Manufacturer, subjected to misuse, misapplication, neglect, alteration, accident or act of God; that has not been installed, operated or maintained in accordance with Manufacturer's installation instructions; that has been exposed to outside substances including but not limited to the following: sand, gravel, cement, mud, tar, hydrocarbons, hydrocarbon derivatives (oil, gasoline, solvents, etc.), or other abrasive or corrosive substances, wash towels or feminine sanitary products, etc. in all pump-

ing applications. The warranty set out in the paragraph above is in lieu of all other warranties expressed or implied; and we do not authorize any representative or other person to assume for us any other liability in connection with our products.

Contact Manufacturer at, 3649 Cane Run Road, Louisville, Kentucky 40211, Attention: Customer Service Department to obtain any needed repair or replacement of part(s) or additional information pertaining to our warranty.

**MANUFACTURER EXPRESSLY DISCLAIMS LIABILITY FOR SPECIAL, CONSEQUENTIAL OR INCIDENTAL DAMAGES OR BREACH OF EXPRESSED OR IMPLIED WARRANTY; AND ANY IMPLIED WARRANTY OF FITNESS FOR A PARTICULAR PURPOSE AND OF MERCHANTABILITY SHALL BE LIMITED TO THE DURATION OF THE EXPRESSED WARRANTY.**

Some states do not allow limitations on the duration of an implied warranty, so the above limitation may not apply to you. Some states do not allow the exclusion or limitation of incidental or consequential damages, so the above limitation or exclusion may not apply to you.

This warranty gives you specific legal rights and you may also have other rights which vary from state to state.

## EASY DO'S & DON'T'S FOR INSTALLING A SUMP PUMP

1. **DO** read thoroughly all installation material provided with the pump.
2. **DO** inspect pump for any visible damage caused by shipping. Contact dealer if pump appears to be damaged.
3. **DO** clean all debris from the sump. Be sure that the pump will have a hard, flat surface beneath it. **DO NOT** install on sand, gravel or dirt.
4. **DO** be sure that the sump is large enough to allow proper clearance for the level control switch(es) to operate properly.
5. **DO Always Disconnect Pump From Power Source Before Handling.**  
**DO** always connect to a separately protected and properly grounded circuit.  
**DO NOT** ever cut, splice, or damage power cord.  
**DO NOT** carry or lift pump by its power cord.  
**DO NOT** use an extension cord with a sump pump.
6. **DO** install a metal check valve and an all metal union in the discharge line.  
**DO NOT** use a discharge pipe smaller than the pump discharge without first consulting pump manufacturer.
7. **DO NOT** use a sump pump as a trench or excavation pump, or for pumping sewage, gasoline, or other hazardous liquids.
8. **DO** test pump immediately after installation to be sure that the system is working properly.
9. **DO** cover sump with an adequate sump cover.
10. **DO** review all applicable local and national codes and verify that the installation conforms to each of them.
11. **DO** consult manufacturer for clarifications or questions.
12. **DO** inspect and test system for proper operations at least every 3 months.

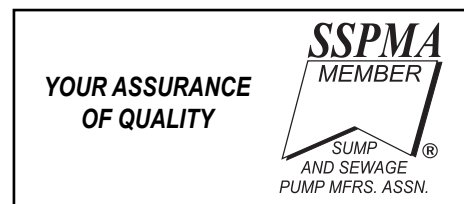

All installations must comply with all applicable electrical and plumbing codes, including, but not limited to, National Electrical Code, local, regional, and/or state plumbing codes, etc.

# TYPICAL HIGH TEMPERATURE PUMP INSTALLATION

Most 200°F. installations do not involve effluent or sewage. (Consult factory)

**CAUTION:** High temperature pumps must be installed in a steel or concrete basin. (Do not use polyethylene or fiberglass type basins.)

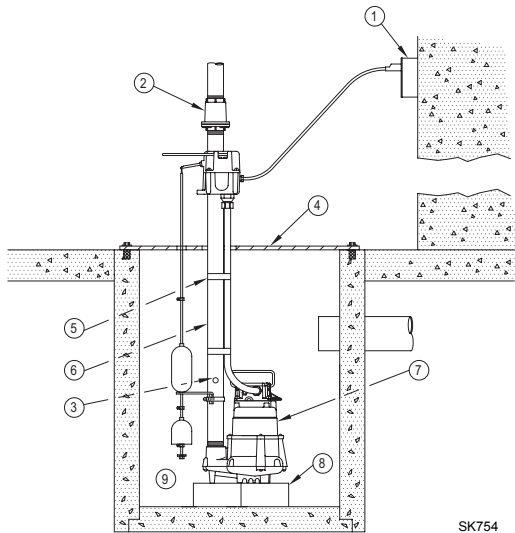

SK754

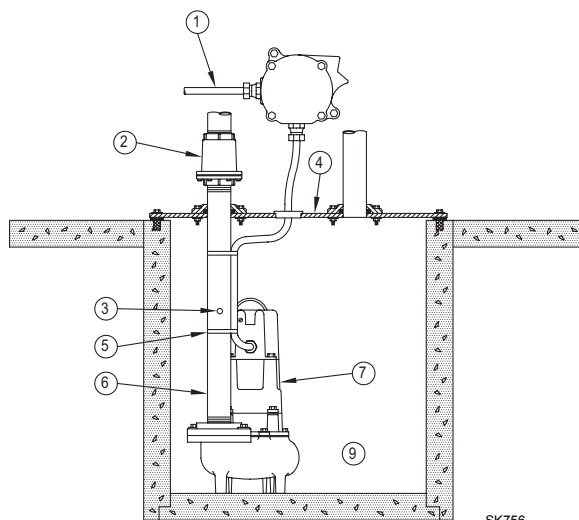

SK756

## Typical High Temperature Automatic Installation.

## Typical High Temperature Nonautomatic Installation.

1. Electrical wiring and protection must be in accordance with National Electrical Code and any other applicable state and local electrical requirements.
2. Install unichek (combination union and check valve) preferably just above the basin to allow easy removal of the pump for cleaning or repair. Use all metal swing type check valve.
3. When a Unichek is installed, drill a 3/16" dia. hole in the discharge pipe even with the top of the pump. NOTE: The hole must also be below the basin cover.
4. All installations require a basin cover to prevent debris from falling into the basin, and to minimize accidental injury.
5. Securely tape power cord to discharge pipe clear of the float mechanism.
6. Use a full-size discharge pipe.
- \*7. Pump must be level and float mechanism clear of sides of basin before starting pump.
8. Install blocks or bricks under pump to provide a settling basin.
9. Basin must be clean and free of debris after installation.

**CAUTION** Switch housing and cord must not be exposed to high temperature water or steam for extended periods. Do not install below the lid or in the pit. If a longer float rod is required for deep pit installations, consult factory.

\*Check specific control installation instruction for other type control usage.

## FLOAT ROD ASSEMBLY INSTRUCTIONS (AUTOMATIC ONLY)\*

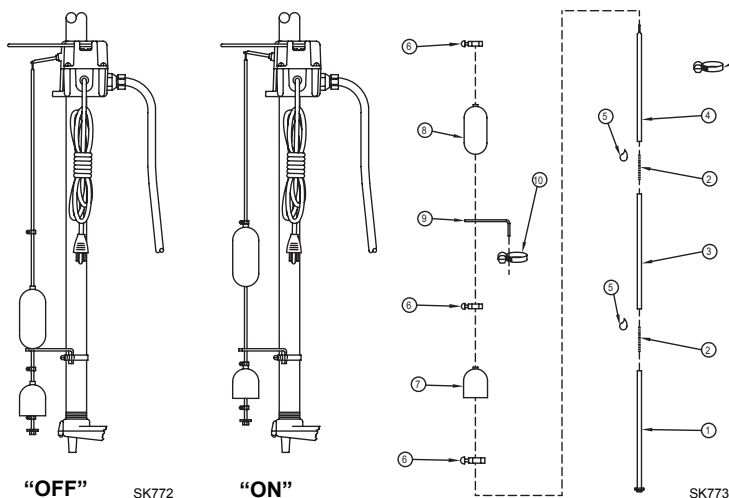

High Temperature "On-Off" Float Positions

High Temperature Float Rod Assembly

1. Slide (2) float stops (6) and small float (7) onto lower float rod (1) as shown. If an extender kit P/N 10-0656 is being used, add additional lower floats provided with the kit.
2. Slide lower float rod (1) thru float rod guide (9).
3. Apply loctite sealant (5) to 1" long stud (2) and insert 1/2" into threaded hole in lower float rod (1).
4. Attach middle section of float rod (3) to lower float rod (1). (Reference step 3.) If an extender kit is being used repeat steps 3 and 4 for each kit used. Each kit adds one float and one foot of float rod length.
5. Slide large float (8) and remaining float stop (6) onto float rod as shown. (Do not tighten float stop set screw at this time.) (Reference step 10.)
6. Attach upper section of float rod (4) to middle float rod section (3). (Reference step 3.)
7. Attach float rod assembly to control box switch arm.
8. Attach control box to discharge pipe at desired level using pipe clamp (10) provided.
9. Attach float rod guide (9) to discharge pipe using pipe clamp provided as shown.
10. Adjust float stops (6) to desired "on-off" levels and tighten set screws.
11. Check float mechanism for free movement. Float must clear pump, discharge pipe, pit, or pit cover.
12. Check your installation. Fill pit with water and check for correct operation and correct "on-off" levels.
13. **CAUTION** Do not touch unit or piping with unit connected to the power source. Adjust as required.

\* The "On" point can be extended in one foot increments using P/N 10-0656. The wire and conduit from pump to switch must be lengthened accordingly, at time of order. Check pump for proper cord/conduit length before starting assembly. Standard cord/conduit length is 3'.

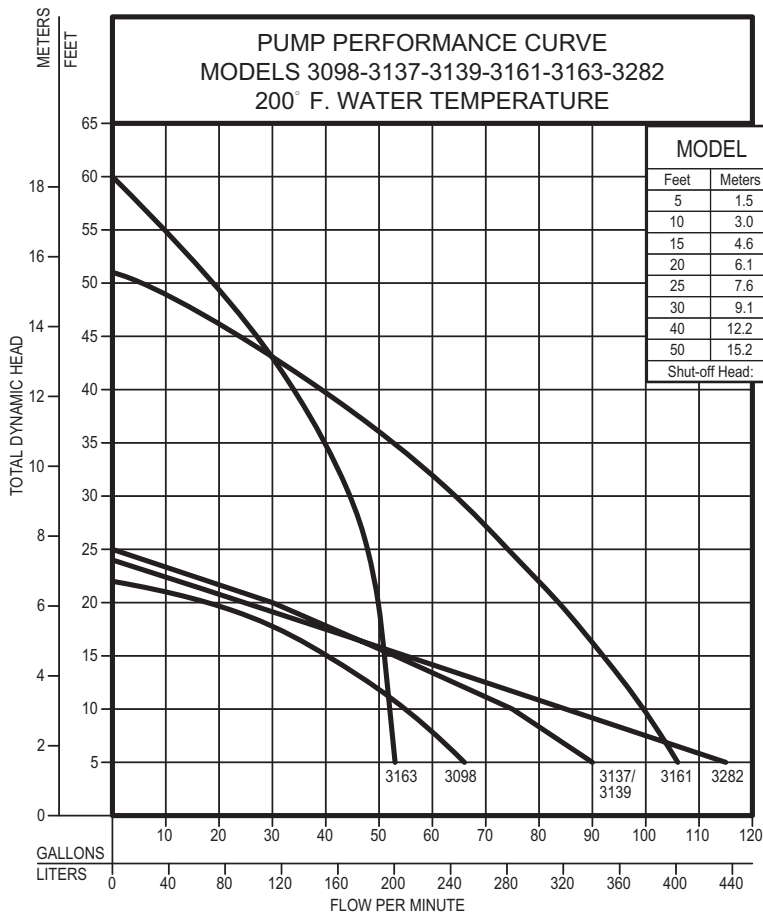

MODEL		3098		3137/3139		3161		3163		3282	
Feet	Meters	Gal.	Liters	Gal.	Liters	Gal.	Liters	Gal.	Liters	Gal.	Liters
5	1.5	66	250	90	341	106	401	53	201	115	435
10	3.0	56	212	75	284	100	378	52	197	85	322
15	4.6	41	155	53	201	92	348	51	193	55	208
20	6.1	23	87	30	114	84	318	50	189	25	95
25	7.6	--	--	--	--	74	280	48	182	--	--
30	9.1	--	--	--	--	65	246	45	170	--	--
40	12.2	--	--	--	--	41	155	35	132	--	--
50	15.2	--	--	--	--	8	30	20	76	--	--
Shut-off Head:		21 ft.(6.4m)		25 ft.(7.6m)		51 ft.(15.5m)		60 ft.(18.3m)		24 ft.(7.3m)	

009789B

009789A

## SERVICE CHECKLIST

**⚠ WARNING** **ELECTRICAL PRECAUTIONS** - Before servicing a pump, always shut off the main power breaker and then unplug the pump - making sure you are wearing insulated protective sole shoes and not standing in water. Under flooded conditions, contact your local electric company or a qualified licensed electrician for disconnecting electrical service prior to pump removal.

**⚠ WARNING** Submersible pumps contain oils which becomes pressurized and hot under operating conditions - **allow 2½ hours after disconnecting before attempting service.**

CONDITION	COMMON CAUSES
<b>A. Pump will not start or run.</b>	Check fuse, low voltage, overload open, open or incorrect wiring, open switch, impeller or seal bound mechanically, defective capacitor or relay when used, motor or wiring shorted. Float assembly held down. Switch defective, damaged, or out of adjustment.
<b>B. Motor overheats and trips overload or blows fuse.</b>	Incorrect voltage, negative head (discharge open lower than normal) impeller or seal bound mechanically, defective capacitor or relay, motor shorted.
<b>C. Pump starts and stops too often.</b>	Float tight on rod, check valve stuck or none installed in long distance line, overload open, level switch(s) defective, sump pit too small.
<b>D. Pump will not shut off.</b>	Debris under float assembly, float or float rod bound by pit sides or other, switch defective, damaged or out of adjustment.
<b>E. Pump operates but delivers little or no water.</b>	Check strainer housing, discharge pipe, or if check valve is used vent hole must be open. Discharge head exceeds pump capacity. Low or incorrect voltage. Incorrect motor rotation. Capacitor defective. Incoming water containing air or causing air to enter pump.
<b>F. Drop in head and/or capacity after a period of use.</b>	Increased pipe friction, clogged line or check valve. Abrasive material and adverse chemicals could possibly deteriorate impeller and pump housing. Check line. Remove base and inspect.
<b>G. Pump seal sensor remains "on".</b>	Lower seal oil cavity contains moisture. Service pump and replace lower seal and oil in seal cavity. If moisture is present in motor housing, the upper seal and oil must be replaced.

If the above check list does not uncover the problem, consult the factory - Do not attempt to service or otherwise disassemble pump. Service must be by Zoeller Authorized Service Stations.