

"QUALITY PUMPS SINCE 1939"

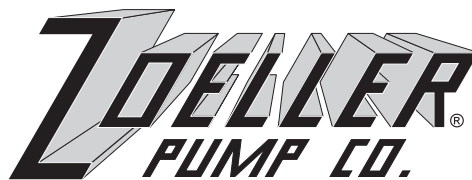

SECTION: 6.10.106  
FM2367  
0306  
Supersedes  
New

Product information presented here reflects conditions at time of publication. Consult factory regarding discrepancies or inconsistencies.

MAIL TO: P.O. BOX 16347 • Louisville, KY 40256-0347  
SHIP TO: 3649 Cane Run Road • Louisville, KY 40211-1961  
(502) 778-2731 • 1 (800) 928-PUMP • FAX (502) 774-3624

visit our web site:  
[www.zoeller.com](http://www.zoeller.com)



## OIL SMART® PUMP SWITCH INSTALLATION INSTRUCTIONS



### WARNING

1. All installations must be in accordance with the National Electrical Code, and any other applicable state and local electrical requirements.
2. **Do not remove ground pin.** Severe electrical shock could occur.
3. Check with local codes for proper installation.



### WARNING

1. The switch and pump are not rated for explosive environments. This product is intended for hydraulic oils only.

#### Installation Instructions for 1 1/2" pipe.

1. Review figures 1,2,3 and 4.
2. Attach Oil Smart® Pump Switch to Quick Mount Bracket using #10 screws and nuts provided (See Figure 1).
3. Snap bracket onto discharge pipe or float tree pipe (See Figure 1).
4. Locate pump switch sensor rod at shut-off height 2" above the pump (See Figure 3 or 4).
5. Place hose clamp on pipe under quick mount bracket (See Figure 1) for reference location of the pump switch.
6. For easy maintenance, just snap bracket off and back on using the hose clamp as a guide.
7. Mount pump switch clear of inlet water and at least 1" to 2" from any metallic material.

#### Installation Instructions other than 1 1/2" pipe.

1. Use the universal PVC bracket and clamp provided.
2. Insert hose clamp through top of bracket. (see figure 2)
3. Mount Oil smart pump switch to universal bracket using # 10 screws and nuts provided.
4. Attach Oil Smart Pump Switch with "off" rod 2" above the top of the pump (See Figure 3 or 4).
7. Mount pump switch clear of inlet water and at least 1" to 2" from any metallic material.

#### Installation instructions for mounting to basin wall.

Reference FM2364 or FM2104.

#### Operation

##### Normal Condition (Water Only)

The short sensor probe turns the pump "on" and the long sensor probe turns the pump "off". When the short sensor is in contact with water, the pump will continue to cycle "on and "off" until the short sensor detects oil.

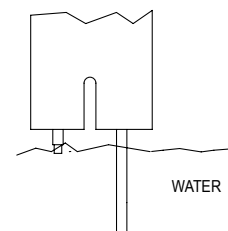

##### Oil Present Condition

The pump will not cycle if oil is in contact with the short sensor.

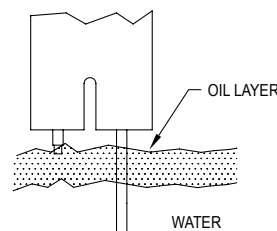

##### High Water (Oil Present Condition)

If additional water enters into the basin it will cause the oil layer to raise above the short sensor resulting in the pump cycling.

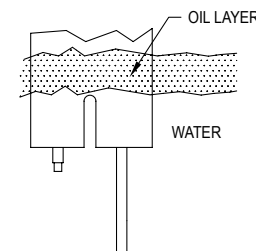

SK2568

#### Maintenance

1. Plastic switch case and metal sensor leads must be kept clean, free of corrosion, mud, soap. Clean switch every four months or as often as environmental conditions dictate.
2. Clean with oil base product like kerosene, solvent or WD40. Do not use soap.

**FIGURE 1** Mounting for 1-1/2" Pipe.

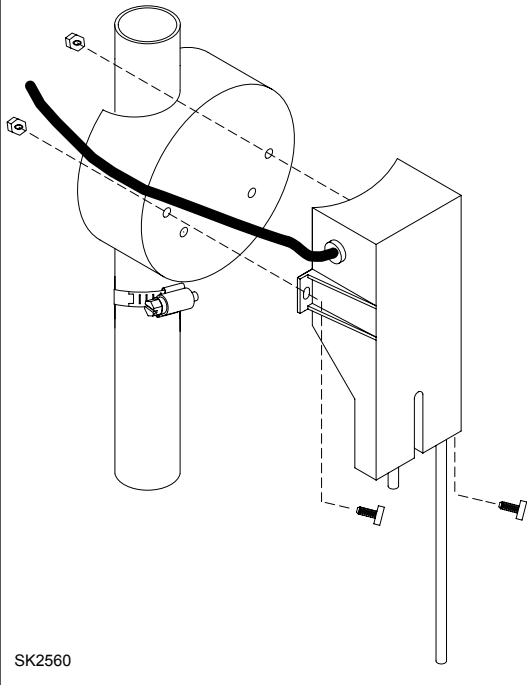

**FIGURE 3** Typical Installation of Oil Smart® Pump Switch and Alarm Panel.

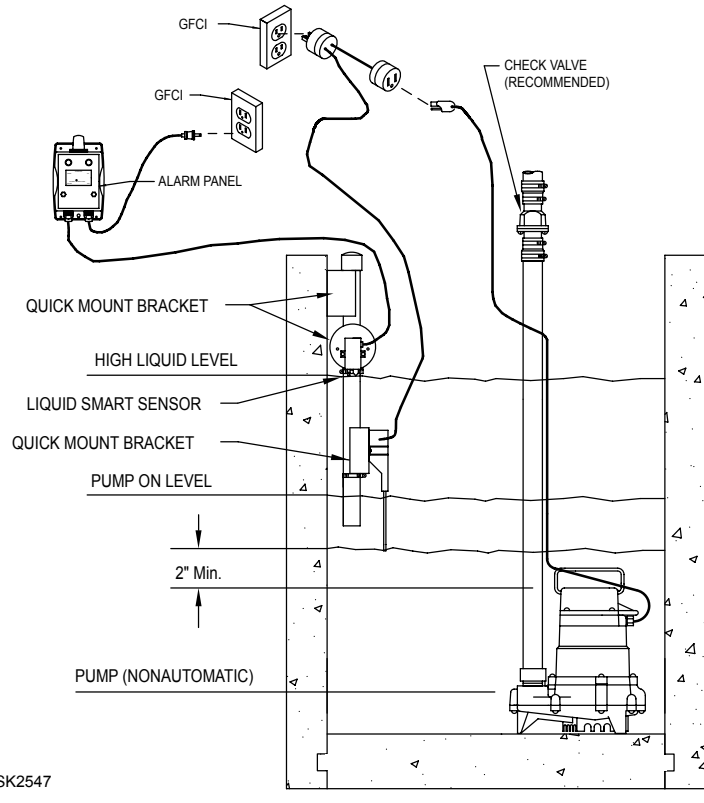

**FIGURE 2** Mounting for Other Than 1-1/2" Pipe.

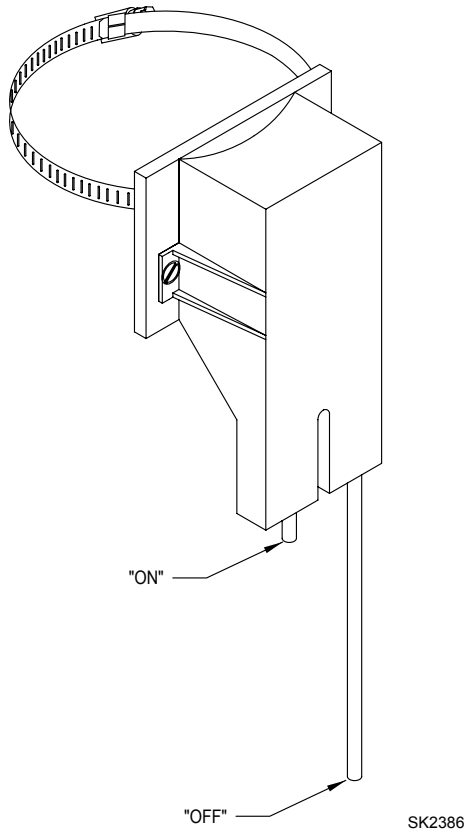

**FIGURE 4** Typical Installation of Oil Smart® Pump Switch and Alarm Panel.

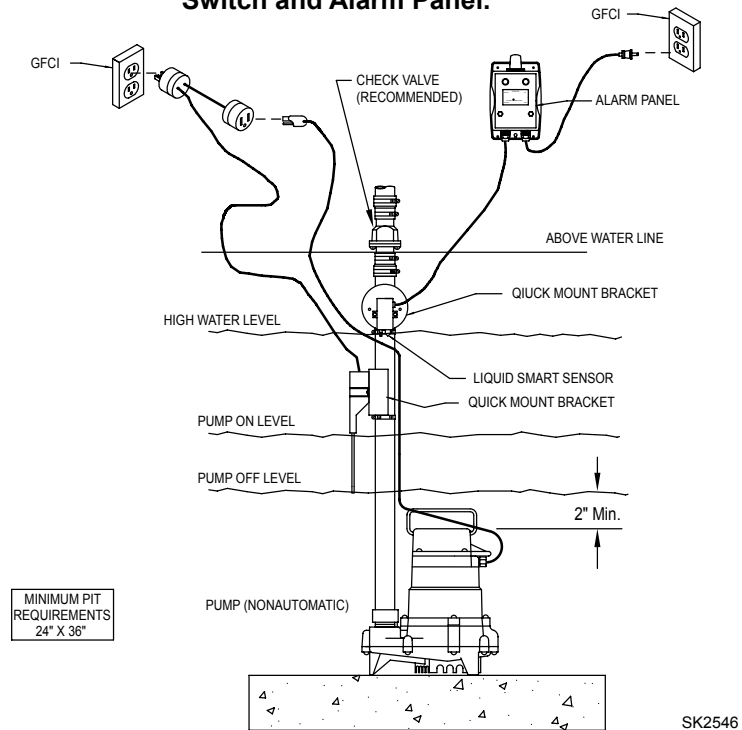

www.zoeller.com

**ZOELLER**  
PUMP CO.

MAIL TO: P.O. BOX 16347  
Louisville, KY 40256-0347  
SHIP TO: 3649 Cane Run Road  
Louisville, KY 40211-1961  
(502) 778-2731 • 1 (800) 928-PUMP  
FAX (502) 774-3624

Manufacturers of..

"QUALITY PUMPS SINCE 1939"