

*"QUALITY PUMPS SINCE 1939"*

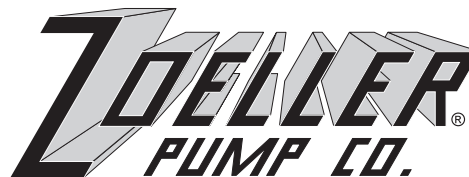

Product information presented here reflects conditions at time of publication. Consult factory regarding discrepancies or inconsistencies.

MAIL TO: P.O. BOX 16347 • Louisville, KY 40256-0347  
 SHIP TO: 3649 Cane Run Road • Louisville, KY 40211-1961  
 (502) 778-2731 • 1 (800) 928-PUMP • FAX (502) 774-3624

visit our web site:  
[www.zoeller.com](http://www.zoeller.com)

# ZOELLER ON-SITE WASTEWATER PRODUCTS

## RISER INSTALLATION INSTRUCTIONS



1. Unpack risers and accessories and examine for any damage that may have occurred during shipping.
2. You may adjust the height on all risers by cutting the top of the riser between any two ribs. The bottom of the riser must remain flat to ensure maximum surface area for adhesive.
3. All covers require a Robertson square head driver for removal.

### Cast-In-Place Adapter (See FIG. 1):

1. Clean and dry the mounting surface on both the riser and adapter using PVC cleaner or lacquer thinner.
2. Apply a 1/2" bead of sealant to all mating surfaces between risers and adapter.
3. Carefully place and align the riser and adapter as illustrated below.
4. Wipe excess sealant from the inside of the riser where possible.

FIG. 1

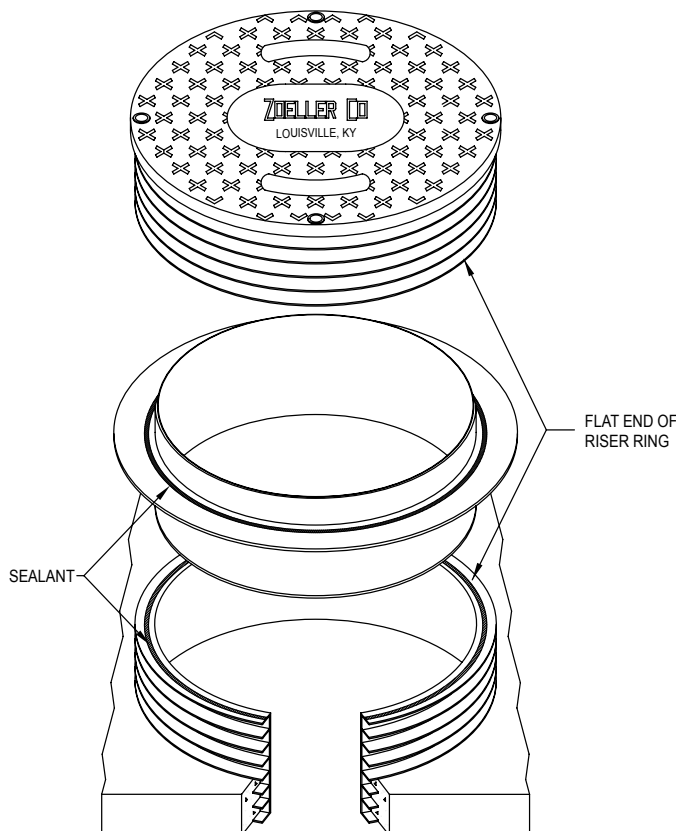

SK2294A

### Bolt Down Kit (See FIG. 2):

1. Clean and dry the mounting surface on both the riser and the septic tank: Wash the top of the tank with detergent and water. Clean the riser's flat bottom flange with PVC cleaner or lacquer thinner to provide the best seal.
2. Apply a 1/2" bead of sealant to the riser's flat bottom flange.
3. Carefully align the riser over the hole in the tank and place the riser down on tank.
4. Drill four 3/8" holes 90 degrees apart. Locate the holes as close as possible to the riser (1/4" max.). Drill the holes at a slight angle to ensure getting as close as possible to the riser. Drill the hole deep enough to allow 1" of stud to be above the concrete. Example: if the stud is 2-3/8" long, drill the hole 1-3/8" deep.
5. Place the large fender washer on first, then the standard washer followed by the nut and tighten.

FIG. 2

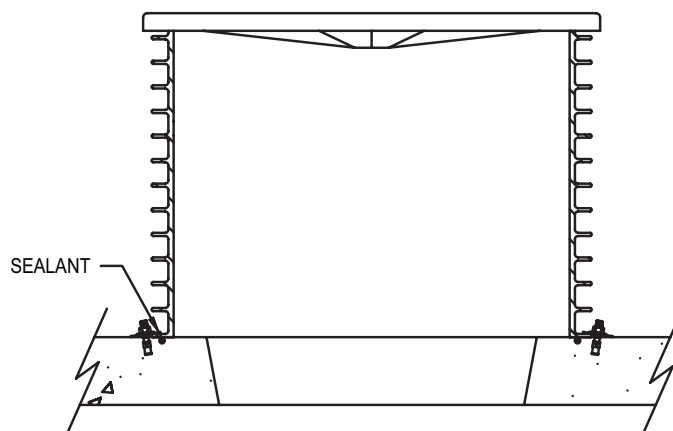

SK2294B

### Seal Ring (See FIG. 3):

1. Clean and dry the mounting surface on both the riser and the septic tank: Wash the top of the tank with detergent and water. Clean the seal ring and riser with PVC cleaner or lacquer thinner to provide the best seal.
2. Position the seal ring on the septic tank, lining up the hole in the top of the tank with the hole in the mounting flange. Draw a line around the outside of the ring on the tank.
3. Remove the ring and apply foam in the area where the ring will set. Apply approximately a 2" bead of foam on the tank or two 1" beads, depending on how much area you have to set the ring on.
4. Position the seal ring back on the tank and apply moderate to firm pressure.
5. Apply approximately a 2" bead of foam at the base of the ring where the riser will sit.
6. Set the riser on the seal ring. Note: on short sections of riser, reach inside the riser and fill any voids between the riser and the seal ring. On long sections of riser, apply a second bead of foam to the vertical section of the seal ring before installing the riser. This will ensure there are no voids between the seal ring and the riser.
7. Wait a minimum of one hour and backfill. Be careful not to damage the riser.

### Epoxy Mounting Risers (See FIG. 4):

1. Clean and dry the bottom flange on the riser and the mounting groove in the septic tank: wash the top of the tank with detergent and water. Clean the riser with PVC cleaner or lacquer thinner to provide the best seal.

2. Fill the groove in the tank half way with adhesive (P/N 172-0019). Approximately 1 quart will work for a 24" or 30" diameter riser.
3. Position the riser down in the groove and apply pressure, submerging the bottom of the riser into to adhesive. Allow adhesive to dry to a firm, watertight seal.
4. Backfill with dirt after adhesive has set for 4 hours and within 24 hours. Be careful not to damage the riser.

### Lockable Latch (See FIG. 5):

1. Center the lid on the riser and install the mounting screws.
2. Drill two 7/16" holes 1" from the edge of the lid approximately 45 degrees from the screws and 180 degrees from each other. The hole should penetrate the lid and the first rib of the riser.
3. If the lock will be below grade, a 4" pipe or larger, cut 6" long (furnished by others) with 3" on one side removed, must be installed next to the riser to allow access to the padlock.
4. Install the stainless steel pins and washers into the 7/16" diameter pin holes. Install padlocks (supplied by others) through the hole in the end of the pins.

### Pipe Seals (See FIG. 6):

1. Drill the appropriate size hole in the side of the riser tube.
2. Place the pipe seal in the riser with the largest diameter inside the riser.
3. To ease pipe installation, lubricate the seal with a mild soap solution such as dish washing liquid. After the pipe is installed, clean off any lubricant.

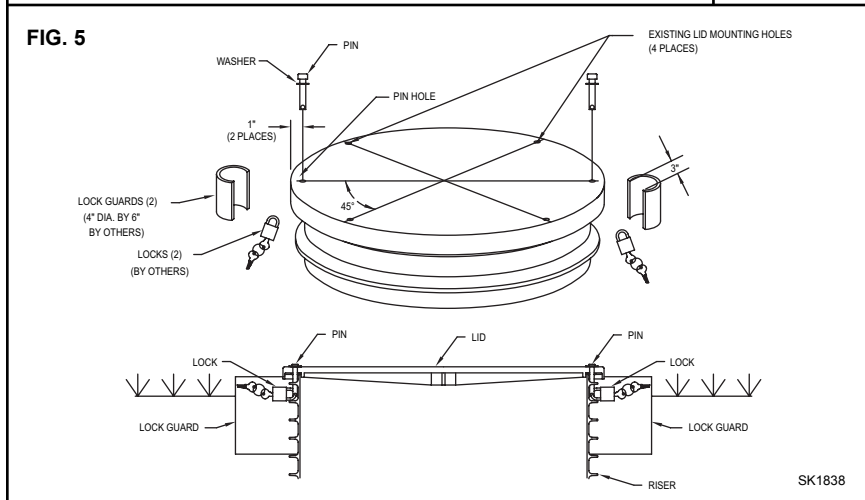
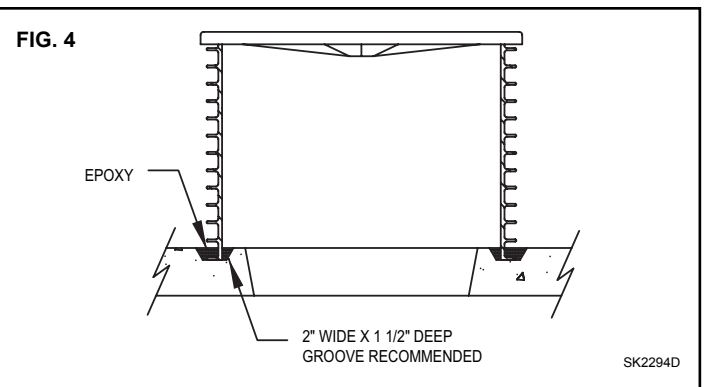
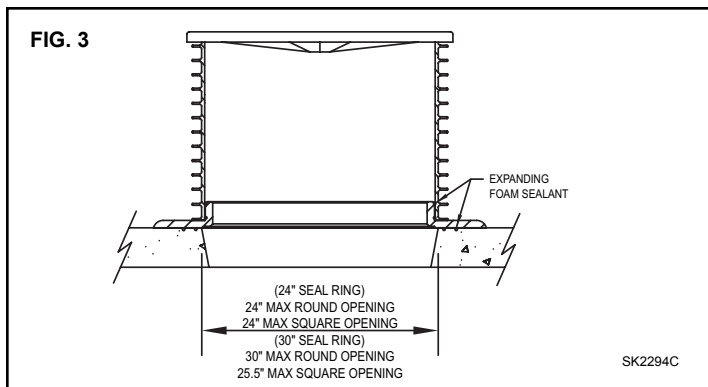

**FIG. 6**

Pipe Seals	
Nominal Pipe Size	Hole Saw Diameter
3/8" IPS	1"
1/2" IPS	1-1/4"
3/4" IPS	1-1/4"
1" IPS	1-3/4"
1-1/4" IPS	2"
1-1/2" IPS	2-1/2"
2" IPS	3"
3" IPS	4"
4" IPS	5"