



RDL®
Radio Design Labs

SPECIALISTS IN PRACTICAL PRECISION ENGINEERING™

max TX™ SERIES TWISTED PAIR Model TX-TPS3A Format-A Three-Pair Sender

- Three -10 dBV Unbalanced or +4 dBu Balanced Inputs
- Phono Jack and Detachable Terminal Block Inputs
- Audio Inputs to Feed Pairs A, B and C
- Utilizes All Three Format-A Pairs
- Powered Locally or Remotely through RJ45 Jack
- Local Power Feeds all Modules Connected to OUTPUT
- Wiring Fault Protection by Automatic Resetting Fuse
- Local Power Input on Terminal Block or dc Power Jack
- Blue LED Indicates Module is Powered
- Studio-Quality Precision Active Balanced Circuitry



The TX-TPS3A is a three-pair audio sending module compatible with RDL Format-A twisted pair products. It is built in the versatile Max-TX series enclosure. The durable adhesives provided with the TX-TPS3A permit permanent or removable mounting. The TX-TPS3A may be rack or surface mounted with optional TX™ series accessories.

APPLICATION: The TX-TPS3A is a three-pair audio sending module compatible with RDL Format-A twisted pair products. Three line-level sources may be connected to the module, each using either the -10 dBV unbalanced RCA phono jack or the +4 dBu balanced detachable terminal block. Studio-quality buffer amplifiers feed the RJ45 OUTPUT at the correct operating level. The TX-TPS3A feeds all three signal pairs in the twisted pair cable. No other sending modules may be connected on the same cable with this module. The TX-TPS3A may be powered directly from a 24 Vdc power supply using either the power jack or the detachable terminal block. Local power connected to the module is also fed to all modules connected to the OUTPUT RJ45 jack. The TX-TPS3A may be remotely powered through the twisted pair cable from any other module, signal distributor or RDL power inserter connected to the same twisted pair cable. Module power is indicated by a front-panel LED.

RDL FORMAT-A features superior audio performance that rivals or exceeds shielded wiring. Design simplicity, ease of installation, unsurpassed flexibility, automatic fused power, exceptional hum rejection, low noise, and low distortion provide designers and installers the optimum choice in economical twisted pair products.

max TX™ SERIES TWISTED PAIR Model TX-TPS3A Format-A Three-Pair Sender

Installation/Operation



EN55103-1 E1-E5; EN55103-2 E1-E4
Typical Performance reflects product at publication time exclusive of EMC data, if any, supplied with product. Specifications are subject to change without notice.

STEP 1: Connect an audio source to each of the inputs (+4 dBu balanced terminal block, or -10 dBV input jack).

STEP 2: Connect 24 Vdc to the power input terminals if this module is not being powered through the twisted pair cable from another module, or if this module is located an excessive distance from the next powered module on the cable. Note: The front-panel power LED will be illuminated if this module is powered. If this module is powering other modules through the cable and if there is a wiring short, the short must be cleared then power must be turned off to this module for 10 seconds to reset the internal protection circuit.

STEP 3: Connect the twisted pair cable(s) and mount the module.

NOTE: Each of the three audio inputs may be fed from either the associated balanced terminal block or unbalanced input jack.

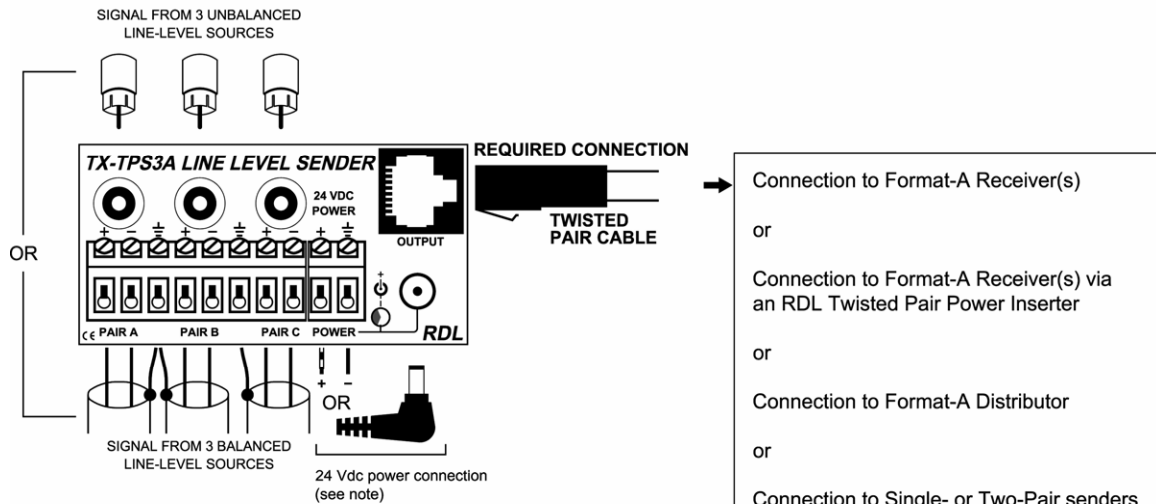

NOTE: Connect a 24 Vdc power supply to the module if power is not being supplied through a twisted pair cable from a connected module.

RJ45 Standard wiring

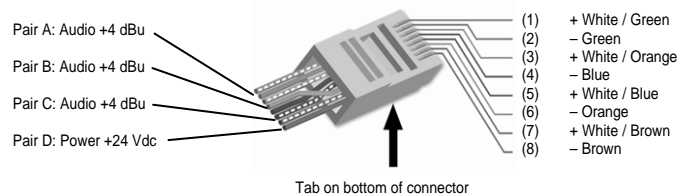

RJ45 conductor colors shown are for 568A standard. The 568B standard may be used if the connectors at both ends of the cable are wired identically.

TYPICAL PERFORMANCE

Inputs (6): 20 kΩ balanced (3); 10 kΩ unbalanced (3)
Input Connection: Terminal Block (Bal.); Phono Jack (Unbal.)
Input Level: +4 dBu Bal.; -10 dBV Unbal.; +22 dBu Max
Format-A Signal Pairs Used (3): A, B, C
Output: RDL TP Format-A
Output Connection: RJ45
Frequency Response: 10 Hz to 50 kHz (+/- 0.1 dB)
THD+N: < 0.005%

Noise below +4 dBu: < 90 dB
Crosstalk: < 85 dB (1 kHz); < 70 dB (20 Hz to 20 kHz)
Headroom above +4 dBu: > 18 dB
CMRR: > 60 dB (50 Hz to 150 Hz)
Indicator: Power In
Power Connections (3): Power Jack; Detachable Terminal Block; RJ45
Power Requirement: 24 Vdc @ 65 mA plus connected loads
Dimensions: 3.0" (7.6 cm) W; 1.6" (4.08 cm) H; 2.09" (5.3 cm) D