

Grounding Hardware

High-Strength Bonding Ground Clamps
Corrosion-Resistant Cast Zinc or Copper Alloy
Zinc-Plated Steel Screws

- 200-230** AWG10 I-Beam Ground-Clamp Bonds Copper Wire to Steel Structure
- 200-292** 3/8" Acorn-type Ground-Rod Clamp
- 200-294** 5/8" Acorn-type Ground-Rod Clamp
- 200-295** Cast-Pipe Bronze Ground-Clamp Bonds Bare Copper Wire to Galvanized or Copper Water Pipe Use with 1/2"-1 3/8" Diameter Pipe
- 200-296** Cast-Pipe Steel Ground-Clamp Bonds Bare Copper Wire to Galvanized or Copper Water Pipe Use with 1/2"-1 3/8" Diameter Pipe
- 200-297** Ground Lug
- 200-298** Meter-Pan Flat Bonding Connector
- 200-299** Meter-Pan Bonding Connector Used in bonding meter-pan metal Frame to AWG10-14 Ground Wire Galvanized Steel Construction Stainless Steel Green Ground Screw

◀ **NEW**
◀ **NEW**

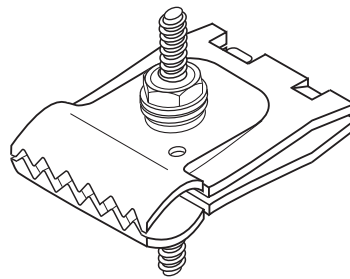

200-230



200-292 3/8"
200-294 5/8"

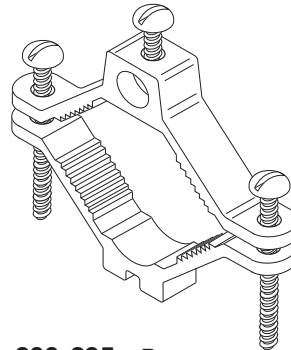

200-295 Bronze
200-296 Steel

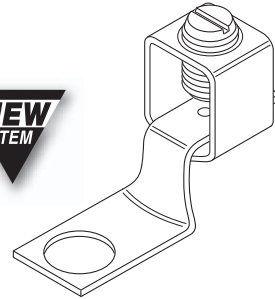

200-297

Split-Bolt Ground Connectors

High-Clamping Force Split-Bolt Connectors Suitable for Copper or Copperweld Connections Constructed of High-Strength Corrosion-Resistant Copper-Bronze Alloy

- 200-244** No. 4 Split-Bolt Connector 8-4 Solid Equal Main and Tap
- 200-246** No. 6 Split-Bolt Connector 10-6 Solid Equal Main and Tap
- 200-248** No. 8 Split-Bolt Connector 16-8 Solid Equal Main and Tap

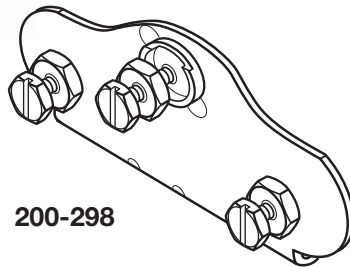

200-298

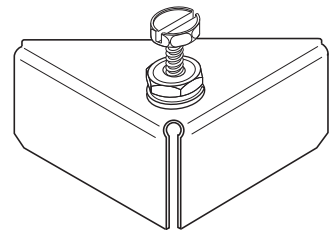

200-299

Aluminum Grounding Wire

- 200-902** 25' AWG8 Aluminum Grounding Wire Suitable Conducting Material for Communications System Grounding

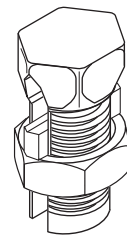

200-244 No. 4
200-246 No. 6
200-248 No. 8

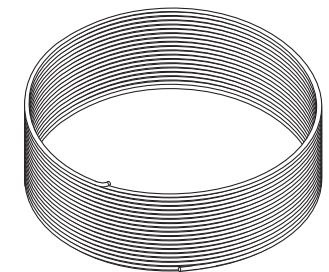

200-902 25' AWG8 Aluminum

Copper Grounding Wire

Copper Wire for All Grounding Applications
Conductor Uncoated Per ASTM B3
Gasoline, Oil, Heat, Moisture Resistant
4 Mil Thick (nom.) Clear Outer Jacket
0.5mm Thick (nom.) PVC Insulation
Meets or exceeds all applicable ASTM specs
Meets or exceeds NEC grounding requirements
600 VAC-UL Listed

- 230-010GR** 500' AWG10 Solid Copper Wire Green Jacket- 2 Spools/Case
- 230-012BK** 500' AWG12 Solid Copper Wire Black Jacket - 4 Spools/Case

◀ **NEW**
◀ **NEW**

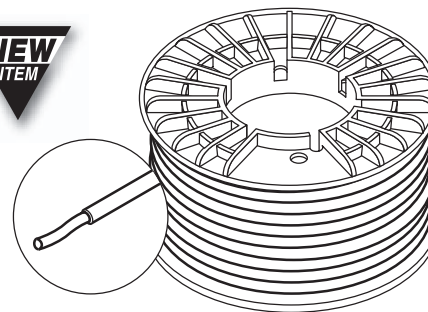

230-010GR 500' AWG10 Copper Green
230-012BK 500' AWG12 Copper Black