

## ACCESSORIES

### Model DRA-35P

### 35 mm DIN Rail Adapter

## Installation/Operation



EN55103-1 E1-E5; EN55103-2 E1-E4  
Typical Performance reflects product at publication time  
exclusive of EMC data, if any, supplied with product.  
Specifications are subject to change without notice.

**Step 3**  
Insert output  
cable through  
slot and tilt  
power supply  
into seated  
position.

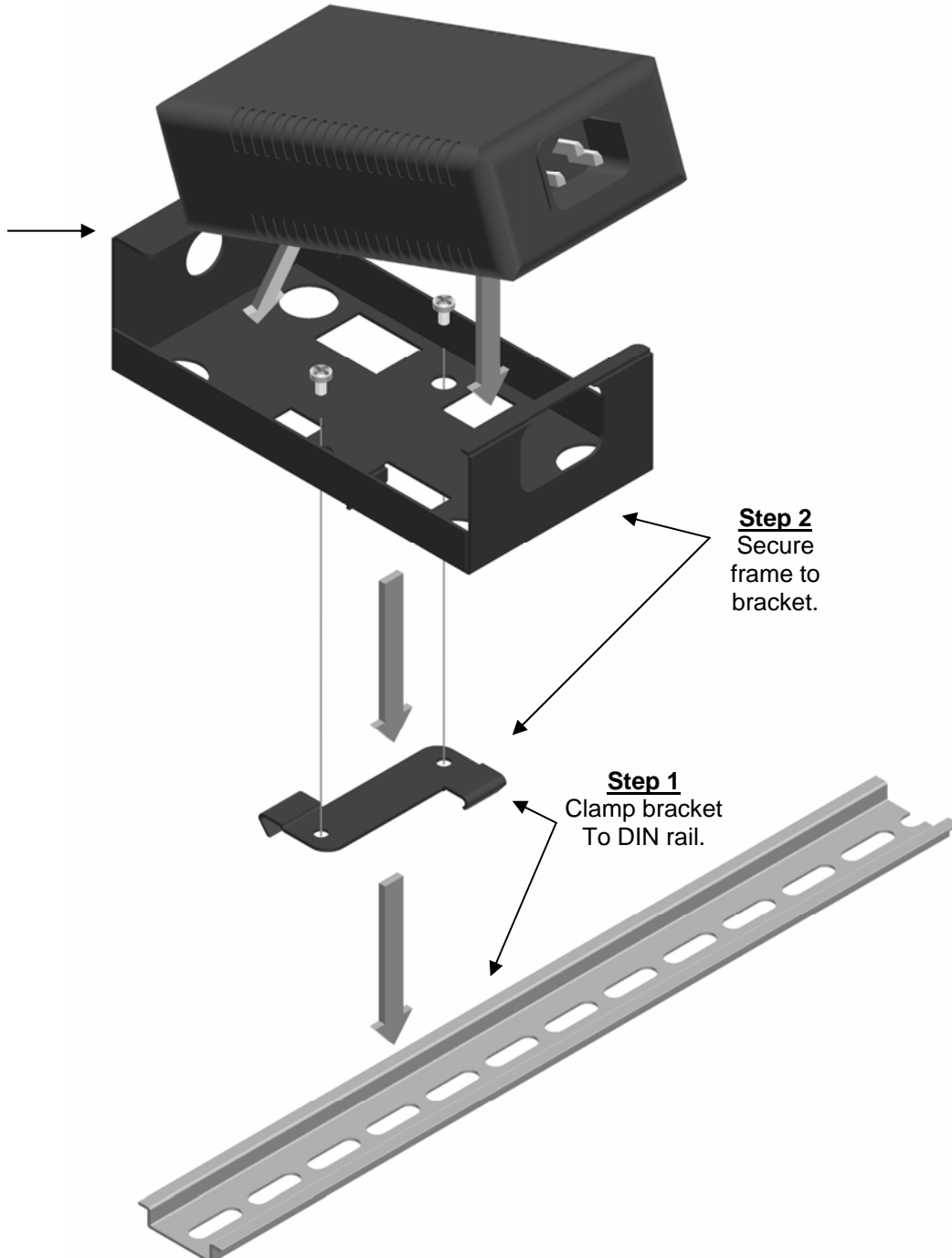

**Step 2**  
Secure  
frame to  
bracket.

**Step 1**  
Clamp bracket  
To DIN rail.