



TWISTED PAIR FORMAT-A



Models AF-TPS1A, D-TPS1A, DS-TPS1A & EM-TPS1A Format-A Single-Pair Senders

- **Balanced Microphone XLR Input with Phantom**
- **Switch-Selectable Mic Gain on Rear Panel**
- **Switch Selects which RJ45 Pair (A, B or C) is Fed**
- **Signal and Power Pair Pass-Through on RJ45 Jacks**
- **Remote Powering through Twisted Pair Cable**
- **Fused Local Power Feeds all Connected Modules**
- **Local Power Input on Terminal Block**
- **Blue LED Indicates Module is Powered**
- **Daisy-Chain with Single-Pair or Two-Pair Senders**
- **Studio-Quality Precision Active Balanced Circuitry**

The -TPS1A modules are single-pair audio sending modules compatible with RDL Format-A twisted pair products. These modules are designed to be mounted in wall boxes, cabinets or other enclosures that allow users to connect audio sources. The D- and DS- models mount in RDL WB-1U and WB-2U wall boxes, or in standard U.S. electrical boxes. The D-TPS1A features a white front-panel laminate with gray lettering that matches RDL Decora®-style remote controls. The DS-TPS1A is constructed of stainless steel to coordinate with RDL Decora-style stainless steel remote controls in commercial/industrial installations. The AF-TPS1A is an APPFLEX™ series product that is compatible with various APPFLEX wall-mount, cabinet-mount and tabletop enclosures. The EM-TPS1A is a 45mm square module that fits the European Modular mounting frames and cover plates. European electrical boxes are not sufficiently deep to accommodate RJ45 jacks and plugs, therefore the EM- products connect to the twisted pair cable through a detachable terminal block.

APPLICATION: The -TPS1A modules feature an XLR microphone input. The module provides IEC 24 V phantom and accepts input signals from both dynamic and condenser microphones. The input signal is amplified using a studio-quality microphone preamplifier optimized for normal operating levels. The rear-panel GAIN switch is normally set by the installer for NORM (normal) gain. If consistently low mic levels are expected, this switch may be set to the HIGH gain position. The pre-amplified microphone source is routed to one output cable pair selected during installation using a rear-panel switch. These modules drive only one cable pair, therefore they accept signals and power from other mic-level or line-level Format-A senders. The D-, DS-, and AF- modules have a second RJ45 jack for these input cables. Installers simply connect the conductors of two cables in parallel on the EM- model terminal block. Two other single-pair senders may be chained with the -TPS1A, or a single two-pair sender may be connected. If three single-pair senders are connected together, each sender must feed a different pair: A, B or C. The TPS1A must be set to feed pair A if it is connected together with an RDL two-pair sender that feeds stereo audio on pairs B and C. The power pair and all three audio pairs are fed through both rear-panel RJ45 jacks.

The -TPS1A may be powered directly from a 24 Vdc power supply using the rear-panel detachable terminal block. Local power connected to the module is also fed to all connected remote modules. The -TPS1A may be remotely powered through the twisted pair cable from any other module, signal distributor or RDL power inserter connected to the same twisted pair cable. Module power is indicated by a front-panel LED. RDL FORMAT-A features superior audio performance that rivals or exceeds shielded wiring. Design simplicity, ease of installation, unsurpassed flexibility, automatic fused power, exceptional hum rejection, low noise, and low distortion provide designers and installers the optimum choice in economical twisted pair products.

TWISTED PAIR FORMAT-A Models AF-TPS1A, D-TPS1A, DS-TPS1A & EM-TPS1A Format-A Single-Pair Senders

Installation/Operation



EN55103-1 E1-E5; EN55103-2 E1-E4
Typical Performance reflects product at publication time exclusive of EMC data, if any, supplied with product. Specifications are subject to change without notice.

STEP 1: Set the MIC gain switch to NORM (normal gain) unless consistently low mic level signals are expected. Set the MIC gain switch to HIGH if low levels are always expected. Note: If both normal and low level mic signals are expected, the gain should be set to NORM to avoid clipping when high levels are connected.

STEP 2: Set the PAIR selector so the module is driving the desired pair A, B or C of the Format-A cable. If the module is connected together with one or two other single-pair senders, each sender must be set to a different pair. If connected together with a two-pair sender, the switch must be set to pair A.

STEP 3: Connect 24 Vdc to the power input terminals if this module is not being powered through the twisted pair cable from another module, or if this module is located an excessive distance from the next powered module on the cable. Note: The front-panel power LED will be illuminated if this module is powered. If this module is powering other modules through the cable and if there is a wiring short, the short must be cleared then power must be turned off to this module for 10 seconds to reset the internal protection circuit.

STEP 4: Connect the twisted pair cable(s) and fasten the module in its mounting box.

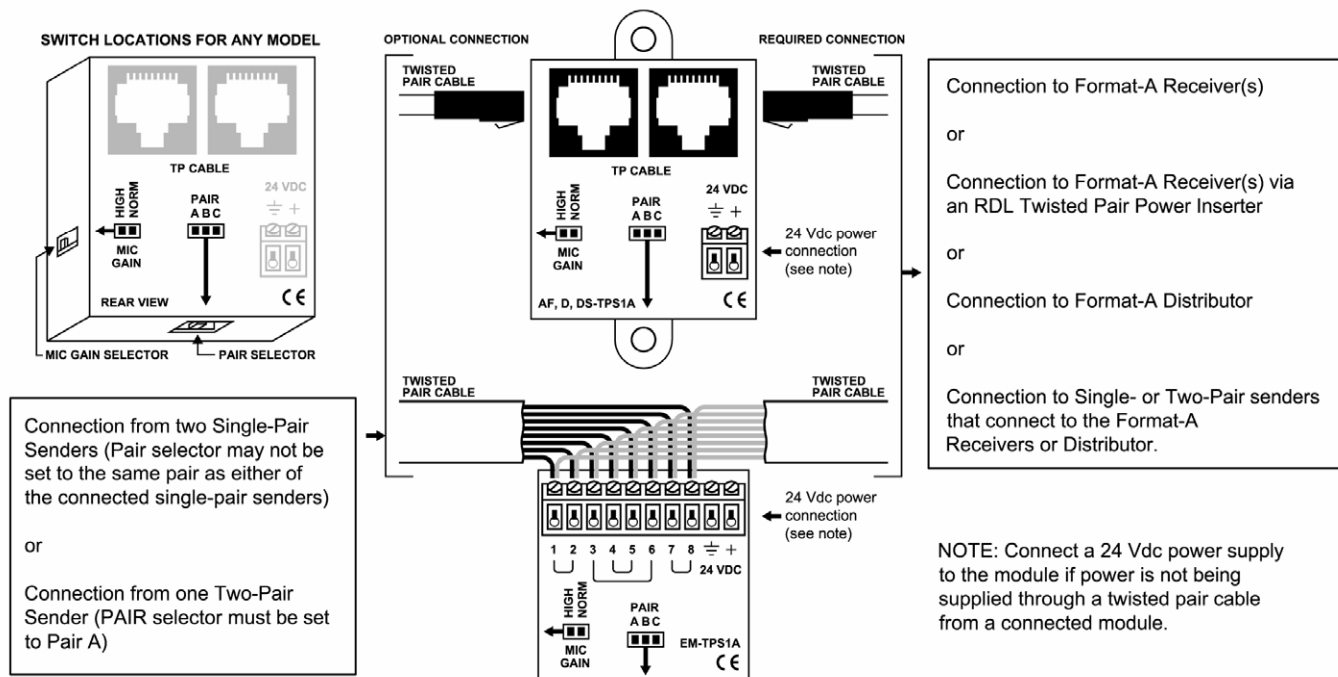

RJ45 Standard wiring

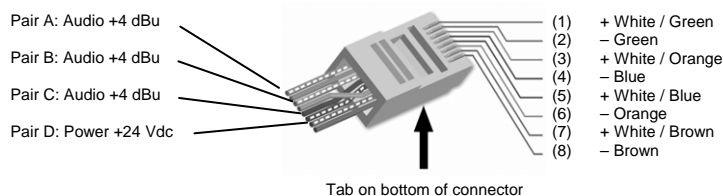

RJ45 conductor colors shown are for 568A standard. The 568B standard may be used if the connectors at both ends of the cable are wired identically.

EM Terminal Block Standard wiring

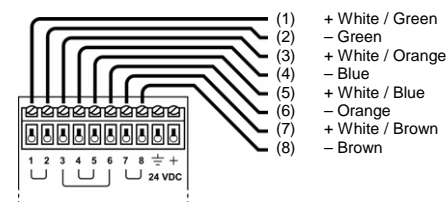

TYPICAL PERFORMANCE

Input Connection: XLR
Input Level: -45 to -65 dBu Bal.; Max: -40 dBu (HIGH Gain), -28 dBu (NORM Gain)
Format-A Signal Pair Used: Switch-selectable A, B, or C
Gain: 50 dB (NORM) or 63 dB (HIGH), Switch-selectable on rear panel
Format-A Input: RJ45 (not applicable to EM-)
Output: RDL TP Format-A
Output Connection: RJ45 (Models D-, DS-, AF-); Detachable Terminal Block (Model EM-)
Frequency Response: 100 Hz to 30 kHz (+/- 1 dB); integral low-cut filter -10 dB @ 30 Hz
THD+N: < 0.1% (80 Hz to 20 kHz)

Noise below +4 dBu: < -80 dB (NORM Gain), < -70 dB (HIGH Gain)
Headroom above +4 dBu: > 18 dB
CMRR (50 to 150 Hz): > 60 dB (HIGH Gain), > 65 dB (NORM Gain)
Indicator: Power In
Power Connections (2): Detachable terminal block; RJ45
Power Requirement: 24 Vdc @ 65 mA plus connected loads
Dimensions: EM-TPS1A: 1.77" (45 mm) W and H; 1.93" (4.9 cm) D
D-, DS-TPS1A: 1.6" (4.06 cm) W; 4.11" (10.45 cm) H; 1.89" (4.8 cm) D
AF-TPS1A: 2.22" (5.64 cm) W; 2.77" (7.04 cm) H; 1.89" (4.8 cm) D
Mounting Box Min. Depth: 2.4" (Models D-, DS-, AF-); 39 mm (Model EM-)

Radio Design Labs Technical Support Centers

U.S.A. (800) 933-1780, (928) 778-3554; Fax: (928) 778-3506

Europe [NH Amsterdam] (+31) 20-6238 983; Fax: (+31) 20-6225-287