

TT-316

Maneuverable Tow Tractor

MODEL	TT-316	
TYPE	Electric	
SPEED (MAX MPH)	6	9.6 km/hr
DRAW BAR PULL (lbs)	320	1423 N
TOWING CAPACITY (lbs)	16,000	7,250 kg
BATTERY COMPARTMENT	38"Wx16"Lx15"H	96cm x 40cm x 38cm
VOLTAGE	36 volt	
TURNING RADIUS (INCHES)	70.5"	179 cm



Tough and Dependable Product Solutions

The TT-316 Tow Tractor is designed to provide reliable service in rugged applications. The three wheel design and low center of gravity ensures maximum safety without compromising any maneuverability.

The TT-316 Tractor utilizes a 36 volt GT drive system equipped with a solid state controller, 7.6 hp DC separately excited motor, and an automotive differential to provide rugged and reliable service for years to come.

Ergonomics and operator safety are key design features. Tilt/telescoping steering wheel, spring-loaded adjustable operator seat, and improved visibility while maneuvering in tight spots makes the TT-316 Tractor one of the most modern tow tractors manufactured.

When equipped with a lift out or roll out battery box system, the TT-316 Tractor can be utilized 24 hours a day.

With a smooth ride and effortless operation provided by front and rear suspension, the TT-316 Tractor is the operator's choice. Other standard equipment including headlight, taillights, stoplights, and reverse alarm, makes the TT-316 Tractor one of the best narrow aisle two tractor values in the industry.

With over 160,000 vehicles in service and over 55 years of experience in the industry, *Taylor-Dunn products are the best way to go about your business.*



Some vehicles may be shown with optional equipment.



TAYLOR-DUNN[®]
Commercial and Industrial Vehicles Since 1949

The best way to go about your business

PERSONNEL CARRIERS



Aristocrat



Roadmaster

BURDEN CARRIERS



Taylortruck



Loadmaster



Model B Series



Electruck



Maintenance Expediter



Stepsaver



Stockchaser

TOW TRACTORS



Towmaster



Mule



TT-316



Model E



Huskey

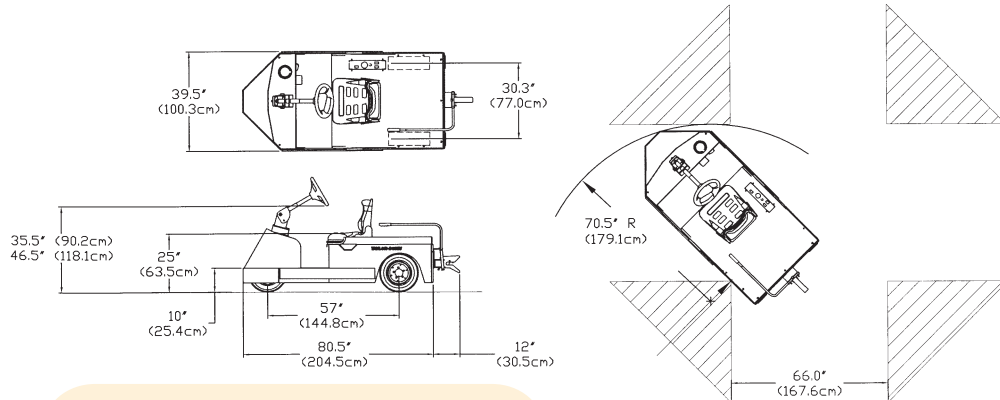

TT-316 STANDARD SPECIFICATIONS

Product Line

Unit Weight	1,150 lbs. (less battery) (520 kg.)
Towing Capacity	16,000 lbs. (7,250 kg.)
Draw Bar pull	320 lbs. (normal) (145 kg); 2,000 lbs. (ultimate) (907 kg)
Battery Compartment Size	36"W x 16"L x 15"H (96 cm W x 40 cm L x 38 cm H)
Battery Weight Range	Minimum 500 lbs., Maximum 1,250 lbs.
System Voltage	36V DC
Drive Axle	GT Automotive type differential
Transmission	Oil Bath, Helical Gears
Motor	7.6 HP DC, Separately Excited
Tires	4.00x8 Soft Solid, Split Rims
Brakes	3 Wheel, Hydraulic Disc, Automatic Parking Brake
Steering	Tilt/Telescoping Gear Steering
Frame	10 Gauge Thick Steel Chassis w/1/2" Thick Side Rails and 1" Thick Rear Panel
Suspension	Coil Springs Front, Leaf Springs Rear
Color	Yellow
Seat	Adjustable w/Spring Suspension
Controller	Solid State, Self Diagnostics
Instrumentation	Maintenance Meter and Battery Status Indicator w/Low Speed Cut Interlock, Hour Meter, DC-DC Converter, Seat Interlock Switch, Fault Display
Light Accessories	Headlight, Taillights, Brake Lights
Hitch	Automatic Coupling
Conformance	Type E OSHA 1910.178, ANSI B56.9

Specifications based on standard vehicle configuration on smooth level surface with unit unloaded.

TT-316 OPTIONAL FEATURES

- Non-Marking Tires
- Mirrors
- Rubber Front Bumper
- Computer Shock Mount
- Speed
- Decouple Handle
- Batteries and Chargers
- Strobe Light
- Paint Color



Some vehicles may be shown with optional equipment.



TAYLOR-DUNN CORPORATION
Commercial and Industrial Vehicles Since 1949



2114 West Ball Road, Anaheim, CA 92804 • (714) 956-4040 • FAX (714) 956-3130
Toll Free (800) 688-8680 Visit our website: www.taylor-dunn.com

Specifications, standard equipment, accessories and modifications subject to change without notice.