

Single-Wall Fiberglass Underground Storage Tanks

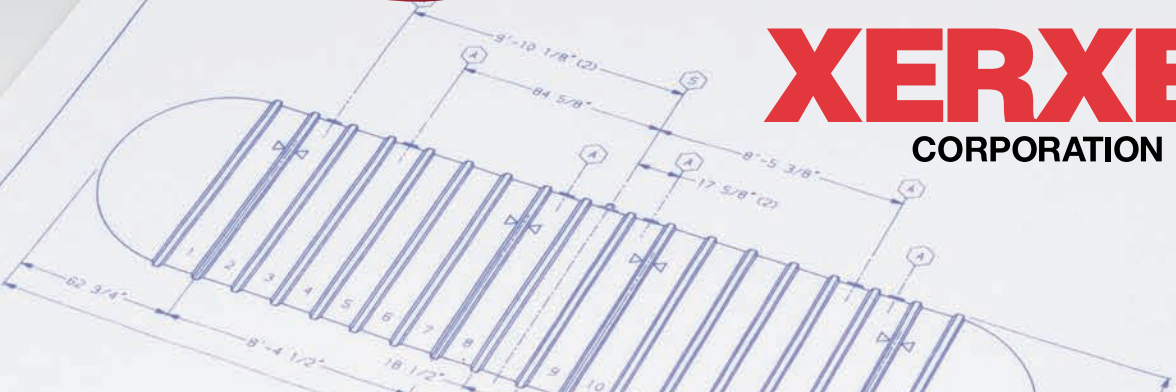

XERXES
NO. 8" DIA. S.W.T.
CAP. 10,000 GALLON
WITH FITTINGS
C 614-172 0

XERXES[®]
CORPORATION

Xerxes Single-Wall Fiberglass Underground Storage Tanks

Index

Xerxes Mission Statement	1
Xerxes Tank Features and Benefits....	2-5
Dimensional Drawings	6-9
Tank Data	10
Optional Tank Accessories	11-12
Guide Specifications	13-14
Limited Warranty	14



The Xerxes Mission Statement

Xerxes Corporation is a leading developer and manufacturer of engineered fiberglass reinforced plastic (FRP) structural products, and marketer of these and other products for the petroleum, chemical, industrial and commercial marketplace. Our efforts are dedicated to providing high-quality, competitively priced products that satisfy the requirements of our customers. We are committed to a philosophy of growth and continual improvement of our products, services, processes and personnel in order to serve our stakeholders – customers, suppliers, employees and stockholders.

Xerxes fiberglass tanks – for today and tomorrow

Xerxes is headquartered in Minneapolis, Minnesota, and operates four manufacturing facilities strategically located to provide prompt delivery and quality service, both economically and efficiently, to any location.

Xerxes' commitment to quality is the foundation of the strong, long-lasting relationships we share with our customers. Unlike less durable goods, Xerxes tanks must perform to standards for decades.

We believe in going the extra mile for our customers. Indeed, it is our commitment to customer satisfaction and quality products that makes Xerxes the first choice in underground storage – for today and tomorrow.

Product line expands as environmental codes change.

For decades, Xerxes has proven itself an industry leader in developing and fabricating engineered fiberglass reinforced plastic (FRP) structural products. As customers' needs change and as regulations become more complex, Xerxes continues its history of innovation by developing products that meet the changing needs of customers in the petroleum, water and wastewater industries.

Today, the Xerxes tank product line includes single-wall, double-wall and triple-wall tanks (in single and multicompartiment models) as well as the XTank® and oil/water separator. These tanks, along with a variety of accessories, provide safe, design-proven and cost-effective underground storage of liquids for a variety of applications.

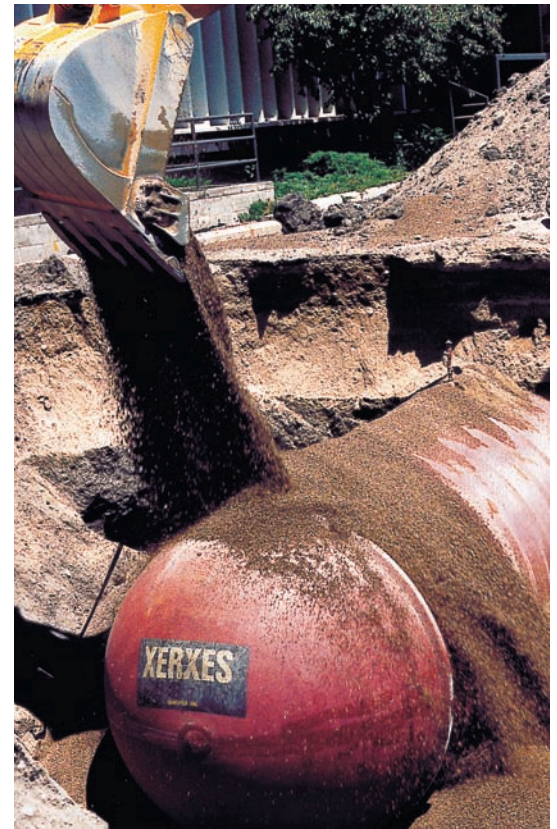

Installation contractor training program

Many local, state and federal agencies, as well as many tank owners, require that UST installers are trained in the proper techniques of underground storage tank installation. Whether or not it is required, Xerxes believes that installation by trained professionals is the key to proper installation and the successful life of a UST system.

Therefore, Xerxes Corporation offers training in the proper installation of our fiberglass tanks. This training – through lecture, videotapes, visual aids and discussion – includes preinstallation handling and testing, backfill-material selection, excavation parameters, proper installation techniques and requirements, and methods for anchoring and ballasting tanks. (See the Xerxes Installation Manual and Operating Guidelines For Single-Wall and Double-Wall Fiberglass Underground Storage Tanks.)

The Xerxes single-wall

Why Xerxes fiberglass tanks?

Xerxes fiberglass underground storage tanks (USTs) offer a number of advantages:

1. A unique integral-rib design and construction of premium-resin and glass-fiber reinforcement make Xerxes fiberglass tanks among the strongest, most robust underground tanks available.
2. Fiberglass construction eliminates the possibility of either internal or external rusting of the tank.
3. Fiberglass tanks are significantly lighter and easier to install than steel tanks, eliminating the need for rental of heavy equipment during installation.
4. Fiberglass tanks can often be moved from an original installation site and be recertified for installation at a new location.
5. Xerxes petroleum storage tanks come with a 30-year limited warranty against structural failure, and internal and external corrosion.

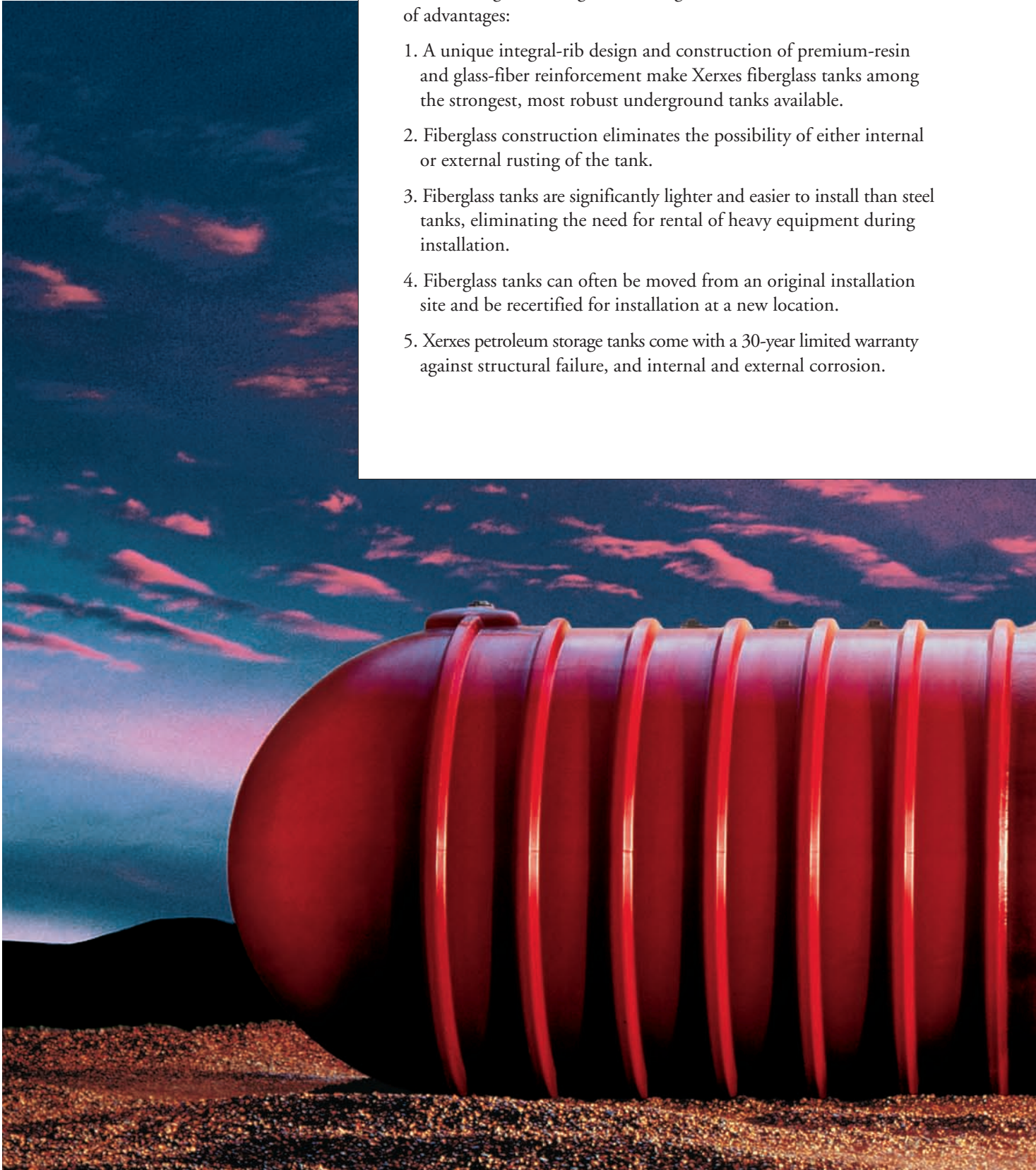

tank is the right choice.

Long history of fiberglass tanks

After years of installing bare steel underground storage tanks for gasoline and diesel fuel, companies discovered, in the early 1960s, that the leakage from steel tanks – because of rust both inside and outside – caused environmental problems. Since the mid 1960s, rustproof fiberglass underground storage tanks (USTs) have provided a reliable option for safe containment of petroleum products.

Xerxes Corporation has been a pioneer in developing, manufacturing and marketing fiberglass tanks for the underground storage of these products, as well as various types of water, wastewater and approved chemicals, since the 1970s.

Today, a large percentage of USTs sold in the United States are made of fiberglass. In fact, approximately 50 percent of all new tank installations are fiberglass and an estimated 99 percent of all tank purchases by major oil marketers are fiberglass. By 2004, more than 420,000 fiberglass tanks had been installed throughout the country.

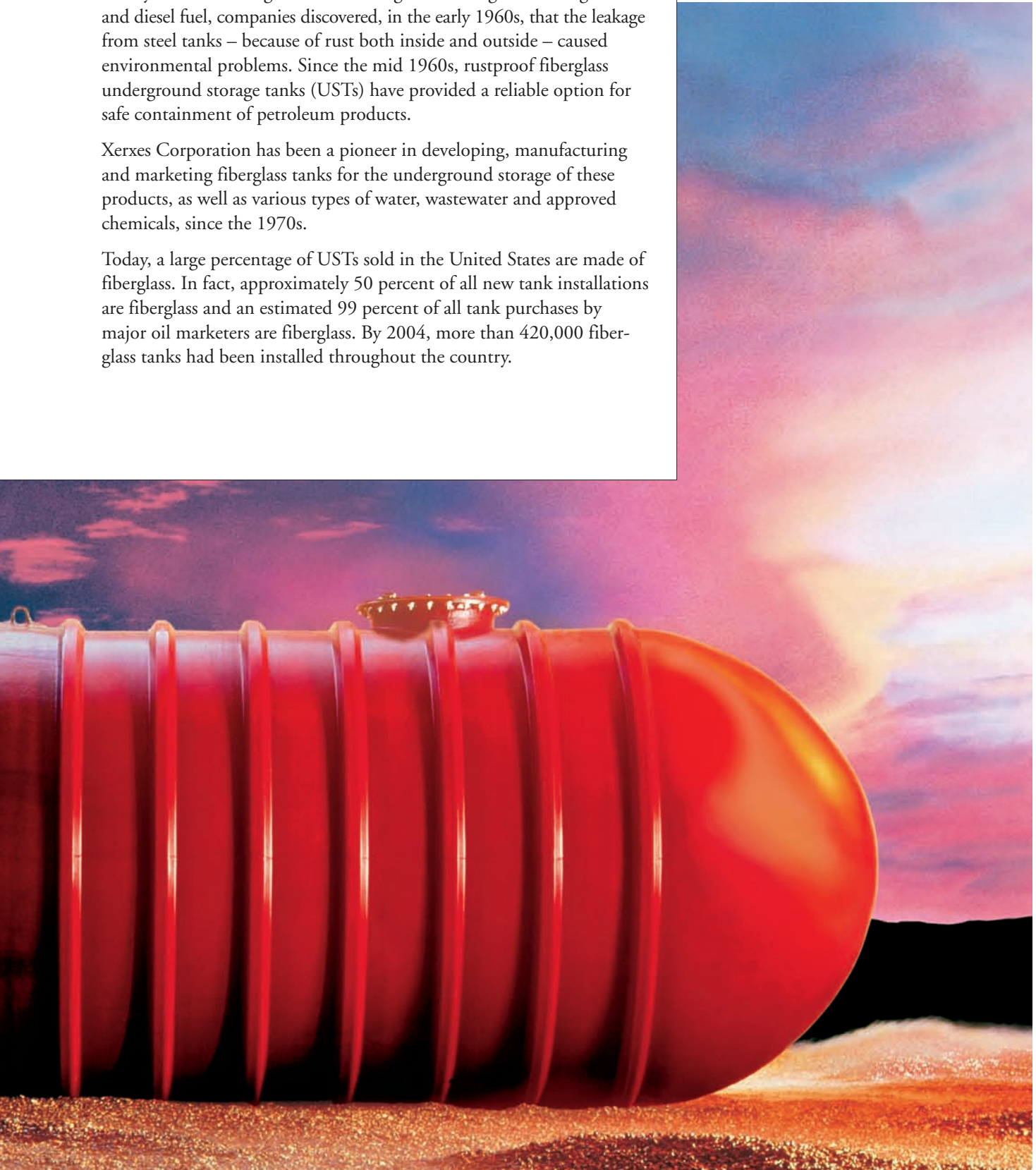

Quality materials and construction mean decades of worry-free service.



Stringent performance standards

Every standard Xerxes single-wall tank is vacuum tested at the factory to 11.5" of mercury, which exceeds the Underwriters Laboratories requirement. In addition, each Xerxes tank is subjected to a 5 psig air/soap test, ultrasonic-thickness verification and a barcol-hardness test. Xerxes' standards meet or exceed those required by Underwriters Laboratories and ensure that every Xerxes tank is a superior investment.

Unique fiberglass design and construction



Xerxes single-wall tanks are manufactured of high-quality resin and glass, and feature a unique integral-rib design. Like fluting in corrugated board, the integral ribs in our fiberglass tanks add strength. The integral ribs and tanks are made of the same materials and are manufactured simultaneously, thus providing an extremely robust product.



Dimensional Data – Standard Single-Wall Tanks

4-Foot-Diameter Tanks

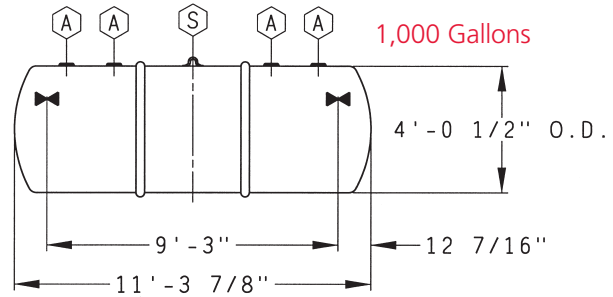
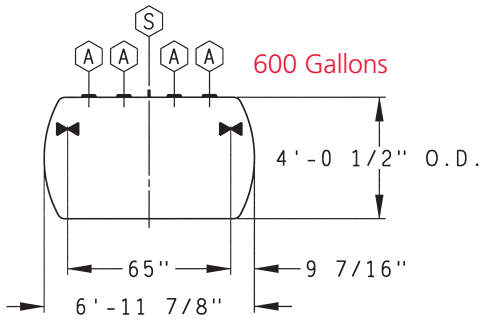

Symbol Identification

-  4"-dia. NPT Fitting
-  Lifting Lug
-  Strap Location



6-Foot-Diameter Tanks

Symbol Identification



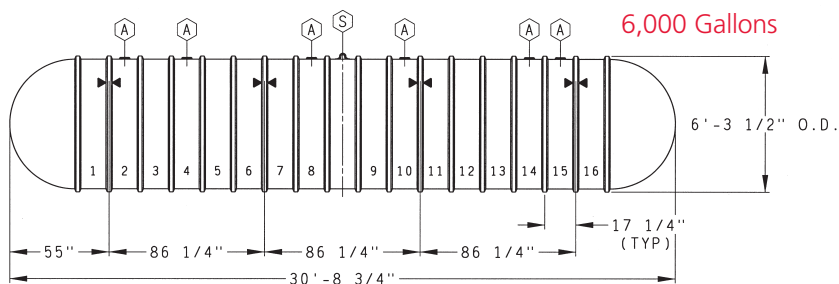
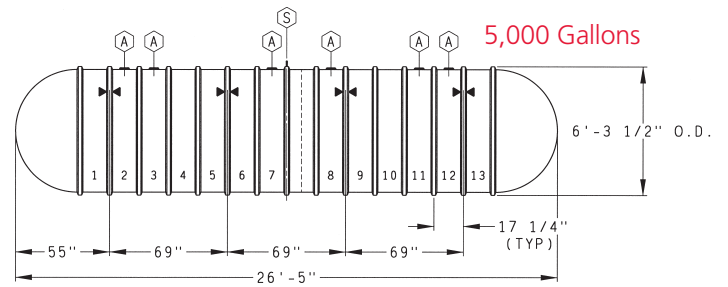
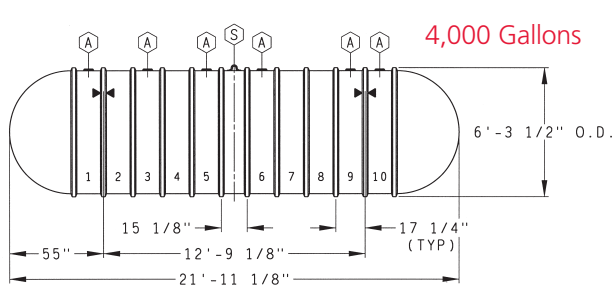
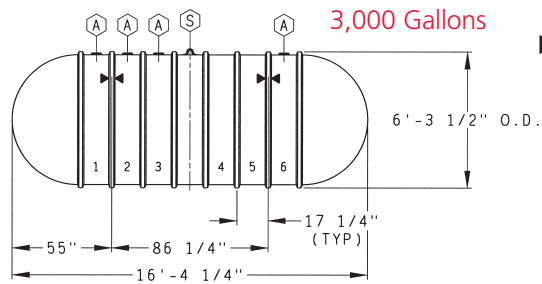
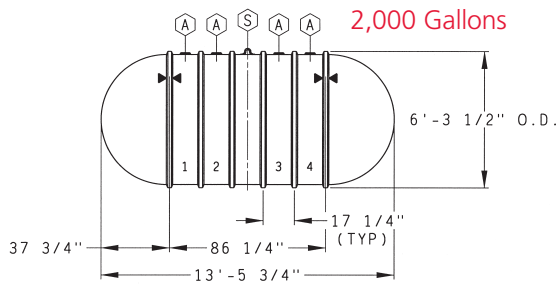

-  4"-dia. NPT Fitting
-  Lifting Lug
-  Strap Location



Dimensional Data – Standard Single-Wall Tanks

8-Foot-Diameter Tanks

Symbol Identification

-  4"-dia. NPT Fitting
-  4"-dia. NPT Duplex Fitting
-  Lifting Lug
-  Strap Location

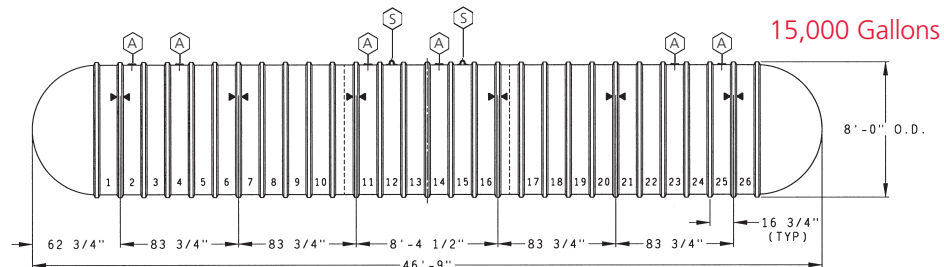
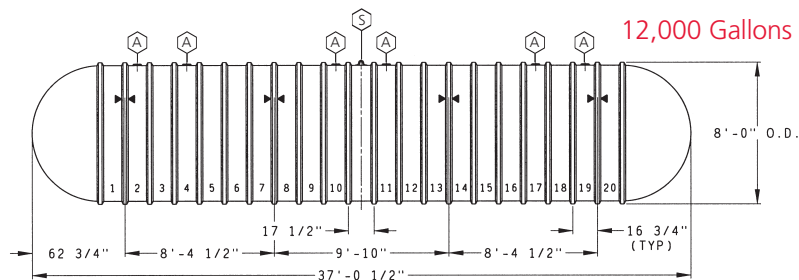
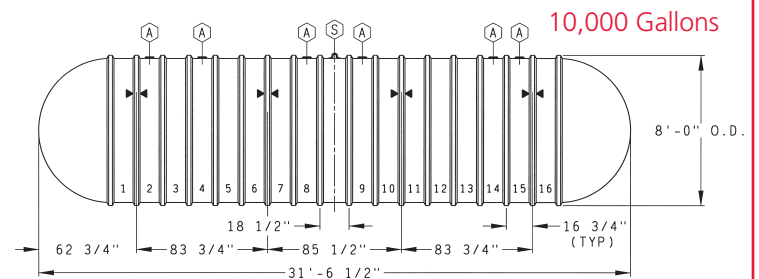
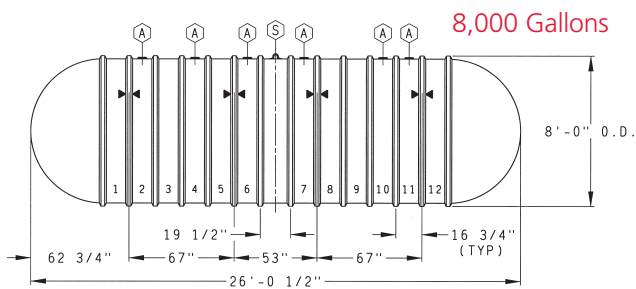
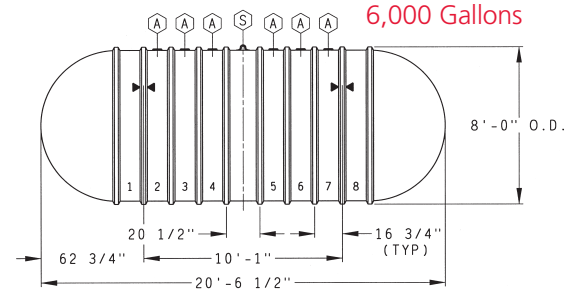
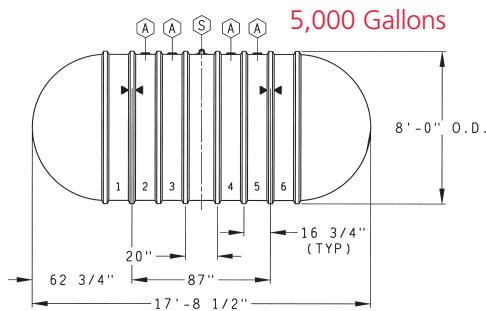
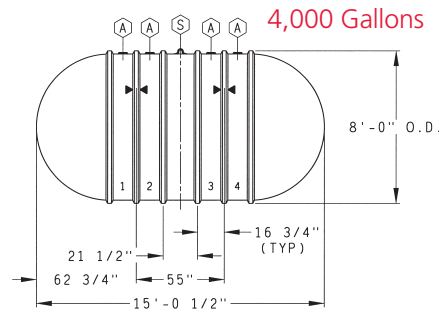
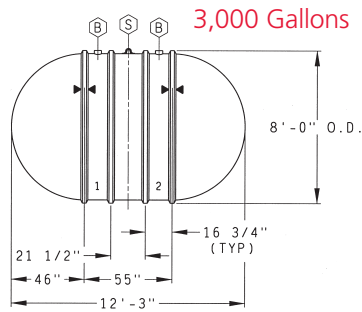
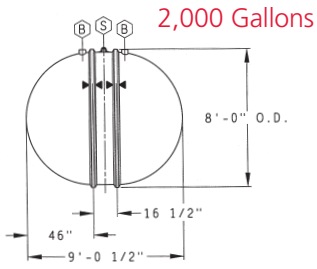

Dimensional Data – Standard Single-Wall Tanks

10-Foot-Diameter Tanks

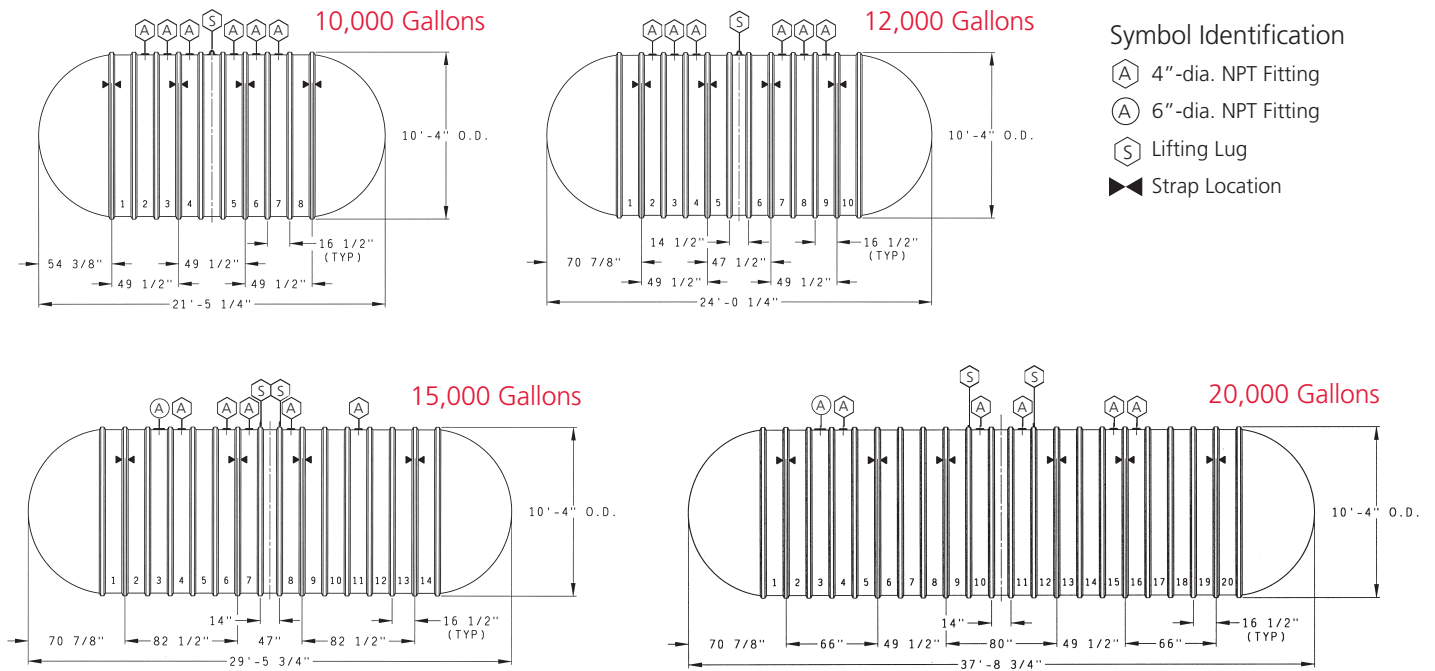

Dimensional Data – Made-To-Order Single-Wall Tanks

10-Foot-Diameter Tanks

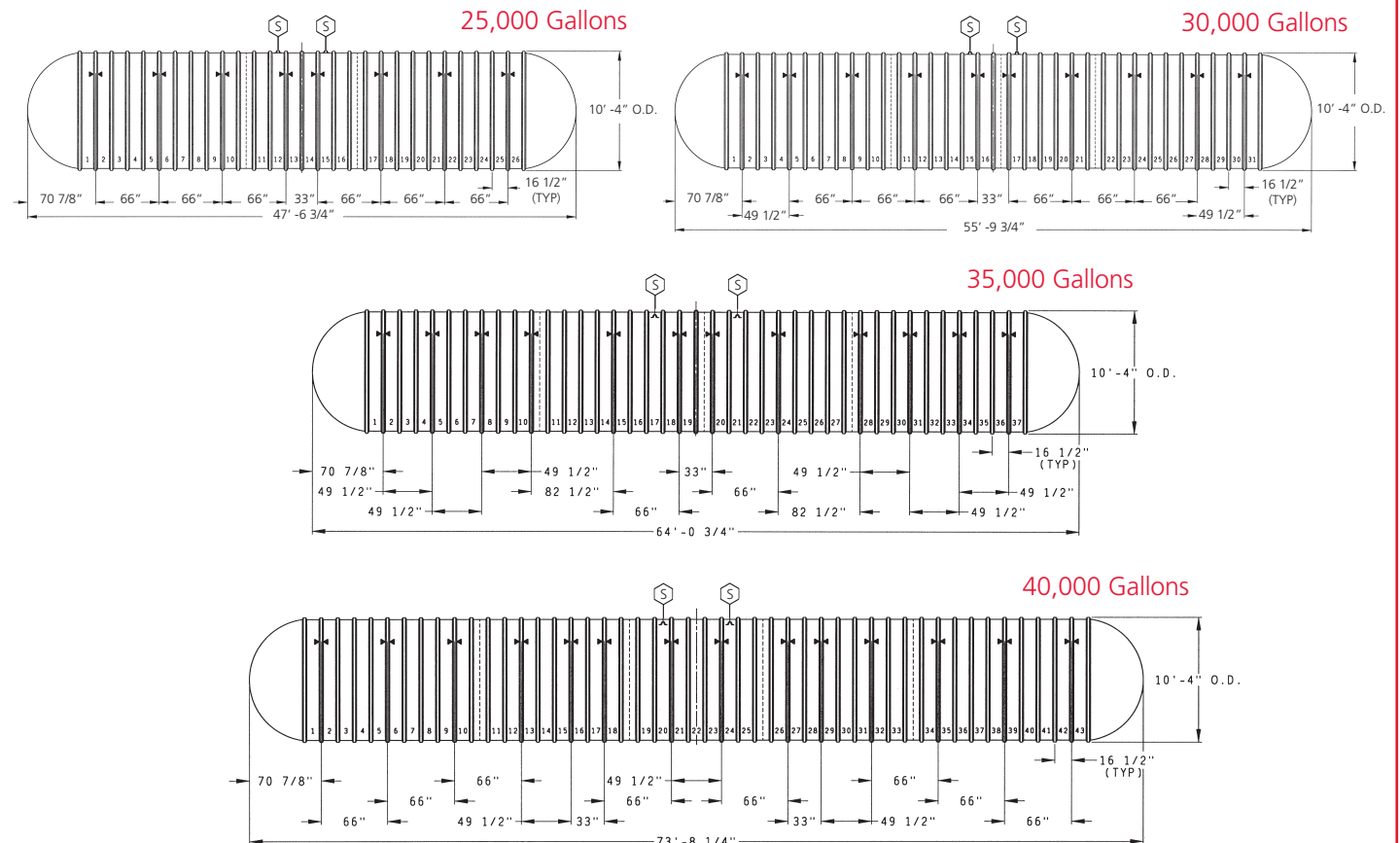

Dimensional Data – Made-To-Order Single-Wall Tanks

12-Foot-Diameter Tanks

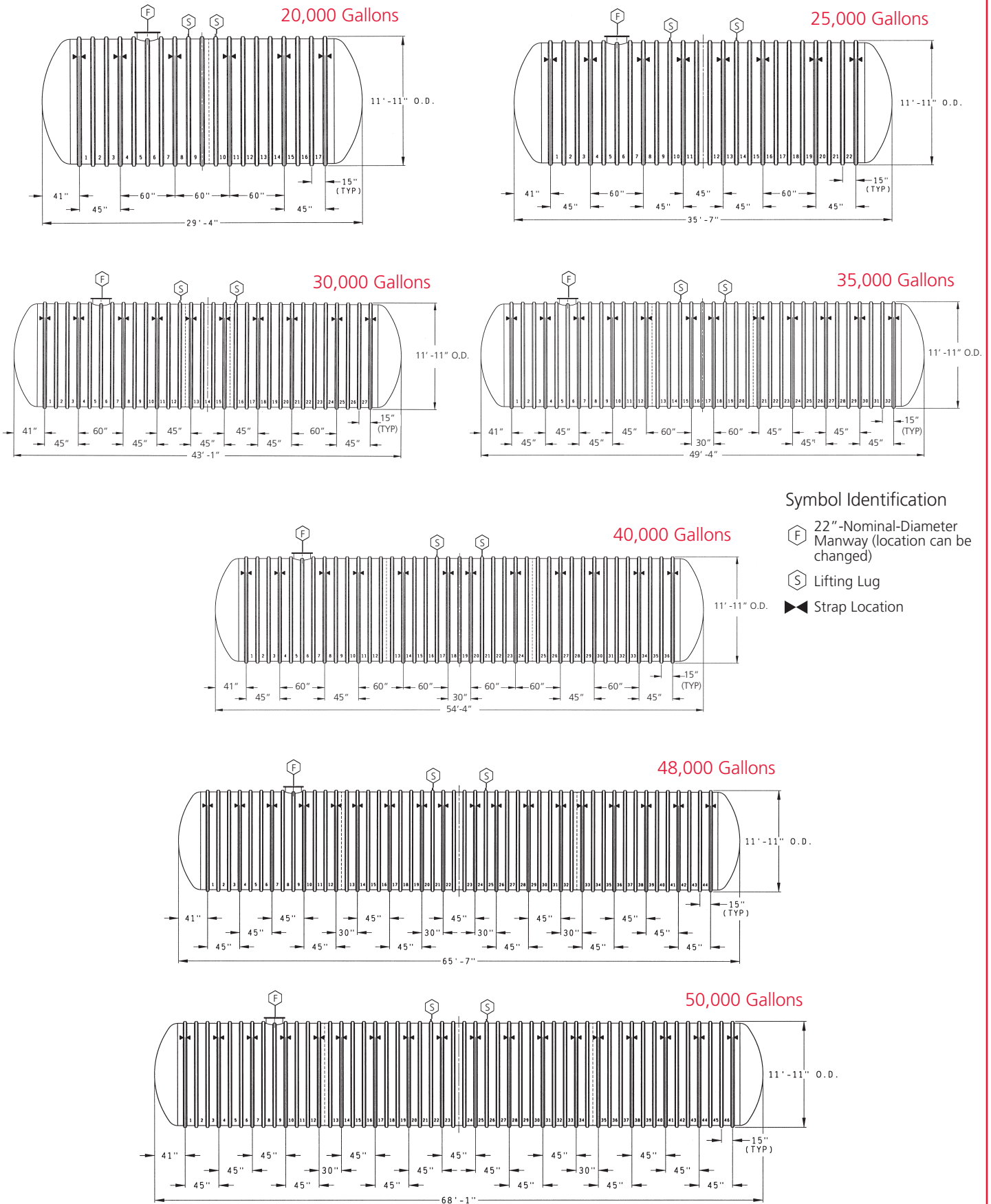

Tank Data

Standard Tank Data

	Nominal capacity (gallons)	Actual capacity * (gallons)	Nominal diameter (w/o accessories)	Overall length	Shipping weight (pounds)	Number & size of fittings	Number of straps (if req'd)
Standard tanks	600	602	4'	6'-11 7/8"	500	4-4"	2
	1,000	1,009	4'	11'-3 7/8"	700	4-4"	2
	2,000	2,376	6'	13'-5 3/4"	1,000	4-4"	2
	3,000	2,993	6'	16'-4 1/4"	1,200	4-4"	2
	4,000	4,131	6'	21'-11 1/8"	1,600	6-4"	2
	5,000	5,064	6'	26'-5"	1,900	6-4"	4
	6,000	5,960	6'	30'-8 3/4"	2,200	6-4"	4
	2,000	2,189	8'	9'-0 1/2"	900	4-4"	2
	3,000	3,271	8'	12'-3"	1,200	4-4"	2
	4,000	4,218	8'	15'-0 1/2"	1,400	4-4"	2
	5,000	5,123	8'	17'-8 1/2"	1,700	4-4"	2
	6,000	6,084	8'	20'-6 1/2"	2,000	6-4"	2
	8,000	7,950	8'	26'-0 1/2"	2,500	6-4"	4
	10,000	9,816	8'	31'-6 1/2"	3,000	6-4"	4
	12,000	11,682	8'	37'-0 1/2"	3,500	6-4"	4
	15,000	14,975	8'	46'-9"	4,500	6-4"	6
	10,000	10,563	10'	21'-5 1/4"	3,200	6-4"	4
	12,000	12,068	10'	24'-0 1/4"	3,600	6-4"	4
	15,000	15,248	10'	29'-5 3/4"	4,500	5-4" / 1-6"	4
	20,000	20,055	10'	37'-8 3/4"	5,700	5-4" / 1-6"	6

Made-To-Order Tank Data

Note: Manways shown on drawings do not depict a standard location. Minimum of one manway is required on 12-foot-diameter tanks.

	Nominal capacity (gallons)	Actual capacity * (gallons)	Nominal diameter (w/o accessories)	Overall length	Shipping weight (pounds)	Number & size of fittings	Number of Straps (if req'd)
Made-to-order tanks	25,000	25,783	10'	47'-6 3/4"	7,900	**	8
	30,000	30,590	10'	55'-9 3/4"	9,400	**	10
	35,000	35,397	10'	64'-0 3/4"	10,500	**	12
	40,000	41,004	10'	73'-8 1/4"	12,100	**	14
	20,000	20,781	12'	29'-4"	9,200	**	6
	25,000	25,541	12'	35'-7"	10,600	**	8
	30,000	31,253	12'	43'-1"	12,500	**	10
	35,000	36,013	12'	49'-4"	13,900	**	12
	40,000	39,821	12'	54'-4"	15,000	**	12
	48,000	48,389	12'	65'-7"	17,700	**	18
	50,000	50,293	12'	68'-1"	18,300	**	18

* Use of overfill protection such as flapper valves or ball-float valves will reduce the actual capacity of the tank.

** Specified by customer

Optional Tank Accessories

Tank Fittings

These NPT fittings allow access to the interior of the tank. Fittings must be located along the top centerline of the tank. They are available in 2", 4", 6" and 8" NPT half-couplings. See standard drawings for size and quantities.

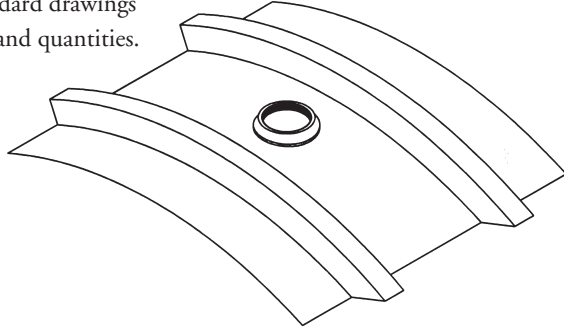

Duplex Fittings

Duplex NPT fittings allow for the placement of two fittings in one location. Fittings are placed on either side of the tank's centerline. Fittings are available in 2", 4" and 6" NPT half-couplings.

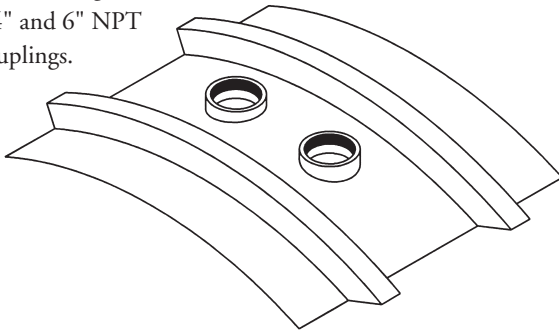

Fiberglass Nozzles – Flanged and Gusseted

Flanged and gusseted fiberglass reinforced plastic (FRP) nozzles are available in 2", 4" and 6" diameters. The flange face matches the ANSI 150# bolting pattern. Mating flanges must be flat-faced. These nozzles may only be placed along the top centerline of Underwriters Laboratories (UL)-listed tanks.

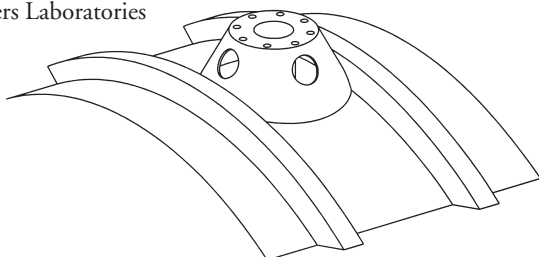

Fiberglass Manways

Manways provide access to the interior of the tank as well as a location for fittings. The standard manway is a 22"-nominal-diameter manway. Manways with nominal diameters of 30" and 36" are available on certain tanks. Each manway is provided with a steel cover, plated bolts, nuts and washers, and a UL-listed gasket.

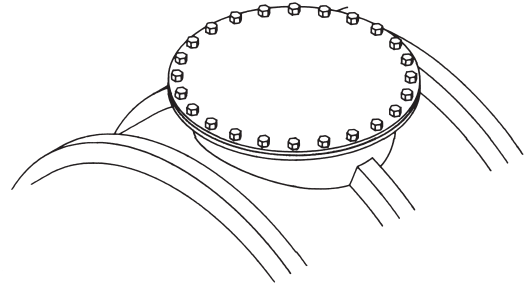

Optional Manway-Cover Fitting Configurations

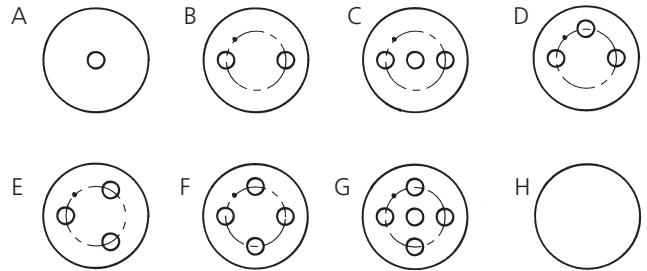

Fitting pattern	No. of fittings (4"-dia. NPT)	Radius from cover center			Spacing
		22"-dia.* Manway	30"-dia.* Manway	36"-dia.* Manway	
A	1	Center	Center	Center	—
B	2	8"	12"	15"	—
C	3	8"	12"	15"	—
D	3	8"	12"	15"	90°
E	3	8"	12"	15"	120°
F	4	8"	12"	15"	90°
G	5	8"	12"	15"	90°
H	0	—	—	—	—

Notes:

- All covers are provided with a 3/8"-dia. NPT plug to bleed manways during precision tank testing.
- Standard fittings are 4"-dia. NPT forged half-couplings.
- Made-to-order covers are available upon request.
- When ordering nonstandard tanks, specify manway-cover fitting configuration.

Bolt-hole configurations

Manway (dia.)*	22"	30"	36"
Dia. of cover	28"	37 1/2"	46"
Bolt-circle dia.	26"	34 1/2"	42 3/4"
Bolt-hole dia.	3/4"	3/4"	3/4"
Bolt size	5/8"	5/8"	5/8"
No. of bolts	24	30	32

* Manway diameter given in these charts is nominal diameter.

Fiberglass Manway Extensions

Tank entry in high groundwater conditions and/or deep burials may require manway extensions. When bolted to the manway, an extension provides a watertight access to the tank interior. Extensions are available in 22", 30" and 36" diameters, and in lengths of 2' or greater. Extensions include nuts, bolts, washers and a gasket.

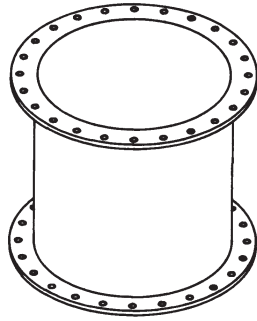

Turnbuckles

Xerxes-supplied turnbuckles are drop-forged and are sized to the tank ordered: 10'-diameter tanks require 3/4" x 18" turnbuckles, 8'-diameter tanks require 3/4" x 12" turnbuckles, 6'-diameter tanks require 3/4" x 9" turnbuckles. Xerxes turnbuckles will connect the tank straps directly to the concrete anchors. No wire rope or clamps are necessary if the required number of turnbuckles is used.

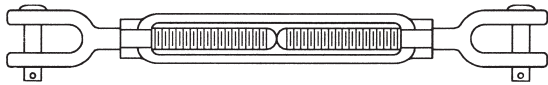

Fiberglass Fill Tubes

Fill tubes are threaded into the bottom of a 6" x 4" NPT double-tapped reducer bushing, which is threaded into a 6" fitting. The bottom of the fill tube is located 4" above the bottom of the tank with the open end slanted 45°.

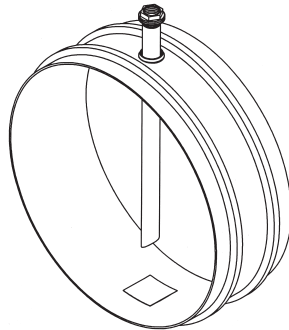

Tank Ladders

FRP, aluminum or carbon-steel ladders are available. Ladders that extend into a manway extension require a 36"-nominal-diameter manway and extension.

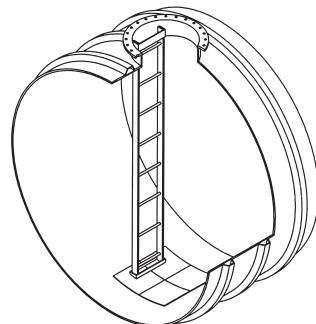

Deadmen

Deadmen supplied by Xerxes are designed to American Concrete Institute (ACI) standards, which include the use of tension and compression reinforcement bars. Galvanized tie-down anchor points are adjustable, making it easier for the installer to properly position them at the hold-down-strap locations on the tank.

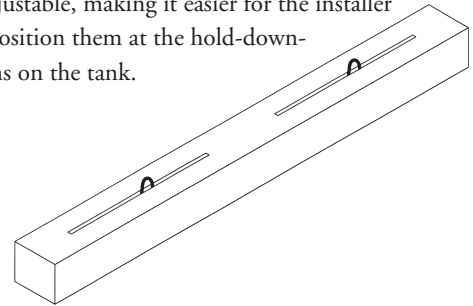

Fiberglass Hold-Down Straps

Straps are used when a tank requires anchoring. The straps provide the link between the tank and the anchoring hardware. For more information on straps and their use, refer to the current Xerxes Installation Manual and Operating Guidelines.

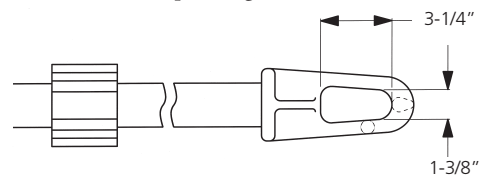

Man-Out-of-Hole (MOH) Straps

Xerxes man-out-of-hole connectors and straps are used as an alternative to standard strap anchor systems when personnel cannot enter the excavation.

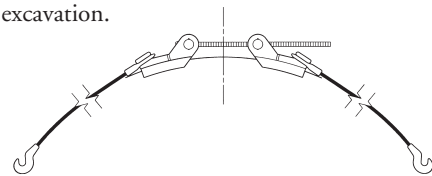

Fiberglass Isolation Risers

Fiberglass isolation risers provide a noncorroding access from the street box down to the top of the tank. Since the bottom is open, the riser will fill with water if water surrounds the outside of the riser. This riser is available in lengths up to 6'.

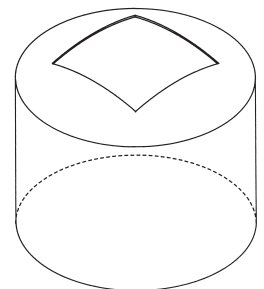

Guide Specifications – Single-Wall FRP Tanks for Fuel Storage

Short form:

The contractor shall provide single-wall fiberglass reinforced plastic (FRP) Underwriters Laboratories-labeled underground storage tank as shown on the drawings. The tank size, fittings and accessories shall be as shown on the drawings. The fiberglass tank shall be manufactured by Xerxes Corporation.

Tank shall be tested and installed according to the Xerxes Installation Manual and Operating Guidelines for Single-Wall and Double-Wall Fiberglass Underground Storage Tanks in effect at time of installation.

Long form:

Part I: General

1.01 Quality Assurance

A. Acceptable Manufacturer: Xerxes Corporation

B. Governing Standards, as applicable:

1. Underwriters Laboratories, Inc. (UL) Standard for Safety 1316, File MH 9061 for storage of flammable liquids. A UL label shall be attached to each tank.
2. National Fire Protection Association (NFPA) Standards:
NFPA 30: Flammable and Combustible Liquids Code
NFPA 30A: Automotive and Marine Service Station Code
NFPA 31: Installation of Oil-Burning Equipment

Part II: Products

2.01 Single-Wall Fiberglass Reinforced Plastic (FRP) Underground Storage Tanks:

A. Loading Conditions – Tank shall meet the following design criteria:

1. Internal Load – Tank shall withstand a 5-psig air-pressure test with 5:1 safety factor. Contractor shall individually test tank for leakage prior to installation. Maximum test pressure is 5 psig (3 psig for a 12'-diameter tank).
2. Vacuum Test – To verify structural integrity, every standard 10'-diameter tank and smaller shall be vacuum tested by the manufacturer at the factory to 11.5" of mercury. 12'-diameter tanks shall be tested by the manufacturer to 5.5" of mercury.
3. Surface Loads – Tank shall withstand surface H-20 axle loads when properly installed according to tank manufacturer's current Installation Manual and Operating Guidelines.
4. External Hydrostatic Pressure – Tank shall be capable of being buried in ground with 7' of overburden over the top of the tank, the hole fully flooded and a safety factor of 5:1 against general buckling.
5. Tank shall support accessory equipment – such as heating coils, drop tubes, submersible pumps and ladders – when properly installed.

B. Product Storage:

1. Tank shall be capable of storing petroleum products with specific gravity up to 1.1.
2. Tank shall be vented to atmospheric pressure.
3. Tank shall be capable of storing products identified in the manufacturer's current limited warranty.

C. Materials:

1. Tank shall be manufactured with 100% resin and glass-fiber reinforcement. No sand fillers.

D. Tank Dimensions (Refer to Xerxes literature on gallonage.):

1. Tank shall have nominal capacity of _____ gallons.

2. Tank shall have nominal outside diameter of _____ feet.

2.02 Accessories

A. Optional Anchor Straps:

1. Straps shall be FRP anchor straps as supplied by tank manufacturer.
2. Number and location of straps shall be specified in current literature by tank manufacturer.

B. Optional Manways:

1. All manways shall be flanged and 22"-nominal-diameter, complete with UL-listed gaskets, bolts and covers. (30"- and 36"-nominal-diameter manways are also available on certain larger tanks.)
2. Location is shown on tank drawings.
3. Optional manway extensions shall be FRP.
4. 12'-diameter tanks require at least one manway.

C. Optional Fill Tubes:

1. Fill tubes shall be FRP, 4"-diameter, with a 6" x 4" double-tapped reducer bushing, and include a 6"-diameter NPT fitting. Tubes shall terminate a minimum of 4" from the bottom of tank (a minimum of 6" for a 12'-diameter tank).

D. Gauge Plates:

1. Gauge plates shall be installed under each fitting.

E. Optional Heating Coils:

1. Optional heating coils shall be installed in a separate 22"-nominal-diameter manway and shall be as supplied by tank manufacturer.

F. Optional Ladders:

1. Ladders shall be the standard ladder as supplied by tank manufacturer (aluminum, carbon steel or fiberglass).

G. NPT Threaded Fittings:

1. All threaded fittings shall be a material of construction consistent with the requirements of the UL label.
2. All standard threaded fittings shall be half-couplings and shall be 4" or 6" in diameter. Reducers are to be used for smaller sizes where shown and provided by contractor.
3. Strength – NPT fittings shall withstand a minimum of 150 foot-pounds of torque and 1,000 foot-pounds of bending, both with a 2:1 safety factor.

Part III: Testing and Installation

3.01 Testing

- A. Tank shall be tested according to the Xerxes Installation Manual and Operating Guidelines for Single-Wall and Double-Wall Fiberglass Underground Storage Tanks in effect at time of installation.

3.02 Installation

- A. Tank shall be installed according to the Xerxes Installation Manual and Operating Guidelines for Single-Wall and Double-Wall Fiberglass Underground Storage Tanks in effect at time of installation.
- B. Contractor shall be trained by the tank manufacturer, the state or other approved agency.

Part IV: Warranty

4.01 Warranty

- A. Warranty shall be manufacturer's limited warranty in effect at time of purchase.

Limited Warranty

Petroleum or Alcohol Fuels Storage for Single-Wall Underground Petroleum Storage Tanks with Resin Specified for Expanded Fuels

Xerxes Corporation ("Xerxes") warrants to ("Owner") that our single-wall underground storage tanks, if installed, used and maintained in the United States, in accordance with Xerxes' published specifications, installation instructions and operating guidelines, and all applicable laws and regulations:

- 1) Will not fail for a period of thirty (30) years from date of original delivery by Xerxes due to natural external corrosion.
- 2) Will not fail for a period of thirty (30) years from date of original delivery by Xerxes due to internal corrosion, provided the tank is used solely, with or without tank water bottoms, to store the following products at ambient temperatures, or fuel oils at temperatures not to exceed 150° F:
 - a. Gasoline, jet fuel, aviation gasolines, motor oils, motor vehicle waste oils, kerosene, diesel fuels, or fuel oils.
 - b. Alcohol, alcohol-gasoline blend, and oxygenated motor fuels:
 1. ethanol and ethanol blends
 - 100% Ethyl Alcohol
 - gasohol (90% gasoline and 10% ethyl alcohol)
 - E 85 (85% Ethanol and 15% gasoline)
 2. methanol and methanol blends
 - 100% methyl alcohol
 - M85 (85% methanol and 15% gasoline)
 - Oxinol-50¹ waiver (90.5% gasoline and 9.5% Oxinol-50¹ comprised of a 4.75% methanol and 4.75% GTBA mixture)
 - Dupont EPA waiver (gasoline with 5% methanol and a minimum of 2.5% cosolvent — the blend may contain a maximum concentration of up to 3.7%, by weight, oxygen in the final fuel)
 3. other oxygenated fuels
 - gasoline with up to 20%, by volume, of methyl tertiary butyl ether (MTBE), ethyl tertiary butyl ether (ETBE), di-isopropyl ether (DIPE), tertiary amyl methyl ether (TAME), or tertiary amyl ethyl ether (TAE).
- 3) Will not fail for a period of thirty (30) years from date of original delivery by Xerxes due to structural failure (defined as spontaneous breaking or collapse caused by material defects in materials or workmanship).
- 4) Will meet Xerxes' published specifications and will be free from material defects in materials and workmanship for a period of one (1) year following the date of original delivery by Xerxes.

Methanol (methyl alcohol) has been designated as "hazardous" in Section 101(14) of the Comprehensive Environmental Response, Compensation, and Liability Act of 1980. Hazardous substances must be stored within secondary containment and have interstitial monitoring, according to federal law.² This warranty is null and void if a single-wall tank has been purchased and installed for products containing a hazardous substance without use of secondary containment and interstitial monitoring as required.

Xerxes warrants to Owner that all Xerxes manufactured tank accessories, if installed, used, and maintained in the United States in accordance with Xerxes' published specifications, installation instructions and operating guidelines, and all applicable laws and regulations, will be free from material defects in materials and workmanship for a period of one (1) year following the date of original delivery by Xerxes.

If any tank is to be removed from an installation, moved to Owner's new location and is intended for active service at the new location, the tank must be recertified by Xerxes in order to maintain the warranty as originally extended. The foregoing warranty does not extend to tanks or accessories (collectively "Goods") damaged due to acts of God, war, terrorism, or failure of Goods caused, in whole or in part, by misuse, improper installation, storage, servicing, maintenance, or operation in excess of their rated capacity or contrary to their recommended use, whether intentional or otherwise, or any other cause or damage of any kind not the fault of Xerxes. Xerxes only warrants repairs or alterations performed by Xerxes or its authorized contractors. Xerxes does not warrant any product, components or parts manufactured by others.

Owner's sole and exclusive remedy for breach of warranty is limited at Xerxes' option to: (a) repair of the defective tank or accessory, (b) delivery of a replacement tank to the point of original delivery, or (c) refund of the original purchase price. A claimant must give Xerxes the opportunity to observe and inspect the tank and accessory prior to removal from the ground or the claim will be forever barred. All claims must be made in writing within one (1) year after tank and/or accessory failure or be forever barred. THE FOREGOING WARRANTY CONSTITUTES XERXES' EXCLUSIVE OBLIGATION AND XERXES MAKES NO OTHER WARRANTY OR REPRESENTATION, EXPRESS OR IMPLIED, WITH RESPECT TO THE GOODS, OR ANY SERVICE, ADVICE, OR CONSULTATION, IF ANY, FURNISHED TO OWNER BY XERXES OR ITS REPRESENTATIVES, WHETHER AS TO MERCHANTABILITY, FITNESS FOR A PARTICULAR PURPOSE, OR OTHERWISE. THE SELLER (XERXES) UNDERTAKES NO RESPONSIBILITY FOR THE QUALITY OF THE GOODS, EXCEPT AS OTHERWISE PROVIDED IN THIS CONTRACT. THE SELLER (XERXES) ASSUMES NO RESPONSIBILITY THAT THE GOODS WILL BE FIT FOR ANY PARTICULAR PURPOSE FOR WHICH YOU (OWNER) MAY BE BUYING THESE GOODS, EXCEPT AS OTHERWISE PROVIDED IN THE CONTRACT. THE REMEDIES SET FORTH IN THE ABOVE WARRANTY ARE THE ONLY REMEDIES AVAILABLE TO ANY PERSON OR ENTITY FOR BREACH OF WARRANTY OR FOR BREACH OF ANY OTHER COVENANT, DUTY, OR OBLIGATION ON THE PART OF XERXES. XERXES SHALL HAVE NO LIABILITY OR OBLIGATION TO ANY PERSON OR ENTITY FOR BREACH OF ANY OTHER COVENANT, DUTY, OR OBLIGATION UNDER THIS WARRANTY EXCEPT AS EXPRESSLY SET FORTH HEREIN. IT IS EXPRESSLY AGREED THAT THIS WARRANTY DOES NOT FAIL OF ITS ESSENTIAL PURPOSE. XERXES SHALL HAVE NO LIABILITY FOR COSTS OF INSTALLATION OR REMOVAL OF GOODS, ENVIRONMENTAL CONTAMINATION, FIRES, EXPLOSIONS, OR ANY OTHER CONSEQUENCES ALLEGEDLY ATTRIBUTABLE TO A BREACH OF WARRANTY, OR INCIDENTAL, CONSEQUENTIAL, PUNITIVE OR OTHER DAMAGES OF ANY DESCRIPTION, WHETHER ANY SUCH CLAIM OR DAMAGES BE BASED UPON WARRANTY, CONTRACT, NEGLIGENCE, STRICT LIABILITY OR OTHER TORT, OR OTHERWISE. IN NO EVENT SHALL XERXES' TOTAL LIABILITY HEREUNDER EXCEED THE ORIGINAL PURCHASE PRICE OF THE GOODS WHICH GAVE RISE TO SUCH LIABILITY.

Consumer Notice: This warranty gives you (Owner) specific legal rights. You (Owner) may also have other rights which vary from state to state.

¹ TM Arco Chemical Co.

² Secondary containment as defined by Federal Law 40 C.F.R. [280.42] (1988), found in the Federal Register Vol. 53 No. 185 (9/23/88)

XERXES®

CORPORATION

7901 Xerxes Avenue South
Minneapolis, MN 55431-1288
Phone (952) 887-1890
Fax (952) 887-1882

www.xerxescorp.com



Manufacturing Facilities

Anaheim, CA
Phone (714) 630-0012
Fax (714) 632-7133

Hagerstown, MD
Phone (301) 223-6961
Fax (301) 223-6836

Seguin, TX
Phone (830) 372-0090
Fax (830) 372-0321

Tipton, IA
Phone (563) 886-6172
Fax (563) 886-2042