



Flow Switches

McDonnell & Miller

Flow Switches – Air

Series AFE-1 Air Flow Switches

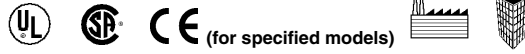

- For industrial hazardous environment applications requiring a **NEMA 7 (Class I, Division I, Group C and D)** or **NEMA 9 (Class II, Division I, Group E, F, and G)** rated flow switch for medium velocity
- 1/2" NPT conduit connection
- Paddle fits 8" (203mm) minimum duct size
- Brass, steel and aluminum construction
- Single pole, double throw snap switch
- Magnetic switching mechanism eliminates need for bellows
- Sensitivity adjusting screw makes flow adjustment easy
- Maximum ambient temperature 120°F (49°C)
- Maximum duct temperature 275°F (135°C)

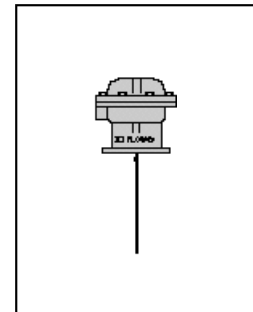
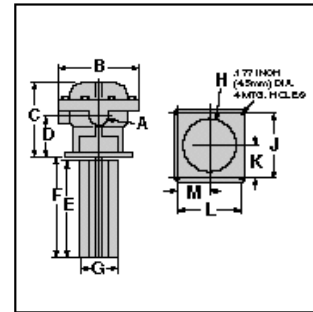

Electrical Ratings

| Voltage | Motor Switch Rating (Amperes) | | Pilot Duty |
|---------|-------------------------------|--------------|--|
| | Full Load | Locked Rotor | |
| 120 VAC | 7.4 | 44.4 | 125 VA at 120 or 240 VAC 50 or 60 cycles |
| 240 VAC | 3.7 | 22.2 | |

Ordering Information

| Model Number | Part Number | Description | Weight lbs. (kg) |
|--------------|-------------|--|------------------|
| AFE-1 | 123010 | Air flow switch w/NEMA 7 & 9 enclosure | 6 (2.7) |
| AFE-1-E | 123011 | AFE-1-CE conformance rated | 6 (2.7) |

See page 132 for CE Conformance information

Flow Rates – feet per minute (meters per minute)

Horizontal Duct (Recommended Installation)

| Mounting/Duct | Settings | Mode of Operation | |
|----------------------|--------------------|-------------------|-------------------|
| | | Flow fpm (mpm) | No Flow fpm (mpm) |
| Top (Recommended) | Factory or Minimum | 300 (91) | 100 (30) |
| | Maximum | 1900 (579) | 500 (152) |
| Side | Factory or Minimum | 350 (107) | 100 (30) |
| | Maximum | 1950 (594) | 900 (274) |

Based on Standard Air 0.075 pounds per Cubic Foot (1.205 kg/m³)
Values are ± 10%

Dimensions, in. (mm)

| A NPT | B | C | D | E | F |
|------------|-------------|-----------------|--------------|-------------|--------------|
| 1/2 | 5 3/4 (146) | 5 13/32 (137.3) | 2 29/32 (74) | 7 1/8 (181) | 7 1/2 (191) |
| G | H | J | K | L | M |
| 2 3/4 (70) | 3 5/8 (92) | 4 3/8 (111) | 2 3/16 (56) | 4 3/8 (111) | 2 13/16 (56) |

Flow Switches