



UNITED BRASS WORKS, INC.

714 S. Main St., Randleman, NC 27317

Tel: 800-334-3035 Fax: 800-498-4696 www.ubw.com



Model 34031

1/2" Short Shank Gauge Fixture Set w/ Ball Valve & Ball Check

250 WSP @ 406°F Max

400WOG

Rising Stem

Aluminum Hand Wheel

Ball Valve for Blow Off

Ball Check to Prevent Leakage, if glass breaks

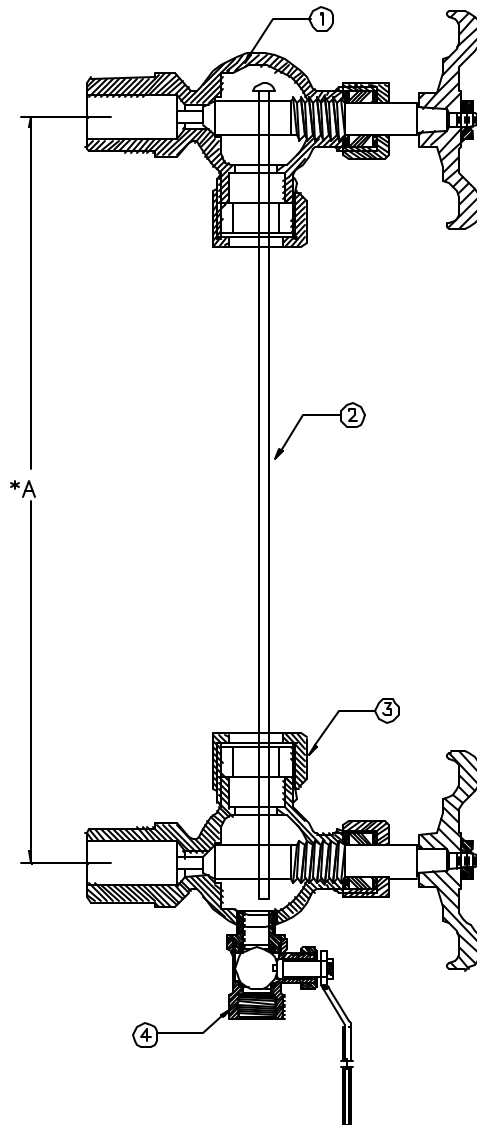

MATERIAL LIST

NO.	DESCRIPTION	MATERIAL
1	Upper Fixture	See Specs for 905AS 1/2"
2	Protector Rods	Steel
3	Lower Fixture	See Specs for 946AXFS 1/2"
4	Ball Valve	See Specs for 80MXF 1/4"

* A To determine proper glass length, subtract 1 1/8" from center to center dimensions of the installed valves.