



UNITED BRASS WORKS, INC.

714 S. Main St., Randleman, NC 27317

Tel: 800-334-3035 Fax: 800-498-4696 www.ubw.com



Sprinkler Head Extensions

200 lbs. WOG
1/2" NPT Male X 1/2" NPT Female
Brass (ASTM B16)
Heavy Knurl

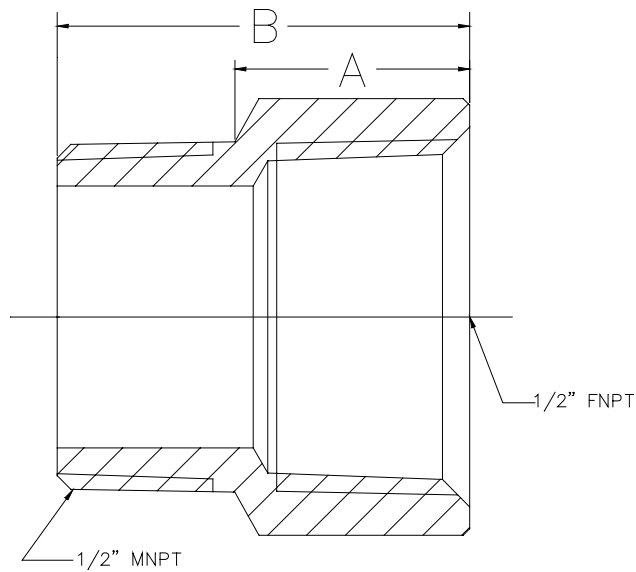

Part #	A Nominal Length	B Overall Length	Weight	Qty./Box
101	0.50	1.00	0.08	100
102	0.75	1.38	0.11	100
103	1.00	1.75	0.16	50
104	1.50	2.25	0.21	50
105	2.00	2.75	0.27	50

Part #101 Threads are shorter than standard to provide minimum length of extension. (Use this size only when absolutely necessary.) These fittings may not seal if mating parts are not made to 1/2" NPT gauge. Use care in applying sufficient thread sealant and tightening properly. Inspect for leaks.