



UNITED BRASS WORKS, INC.

714 S. Main St., Randleman, NC 27317

Tel: 800-334-3035 Fax: 800-498-4696 www.ubw.com



Model 946A 1/2" Short Shank Lower Fixture

250 WSP @ 406°F Max

400WOG

Rising Stem

Bronze Body

Aluminum Hand Wheel

MATERIAL LIST

NO.	DESCRIPTION	MATERIAL
1	Screw	Steel
2	Hand Wheel	Aluminum
3	Stem	Brass
4	Packing Nut	Brass
5	Washer	Brass
6	Glass Washer	EPDM
7	Glass Washer Nut	Brass
8	Washer	Steel
9	Body	Bronze
10	Drain Cock	Brass
11	Packing	PTFE Aramid

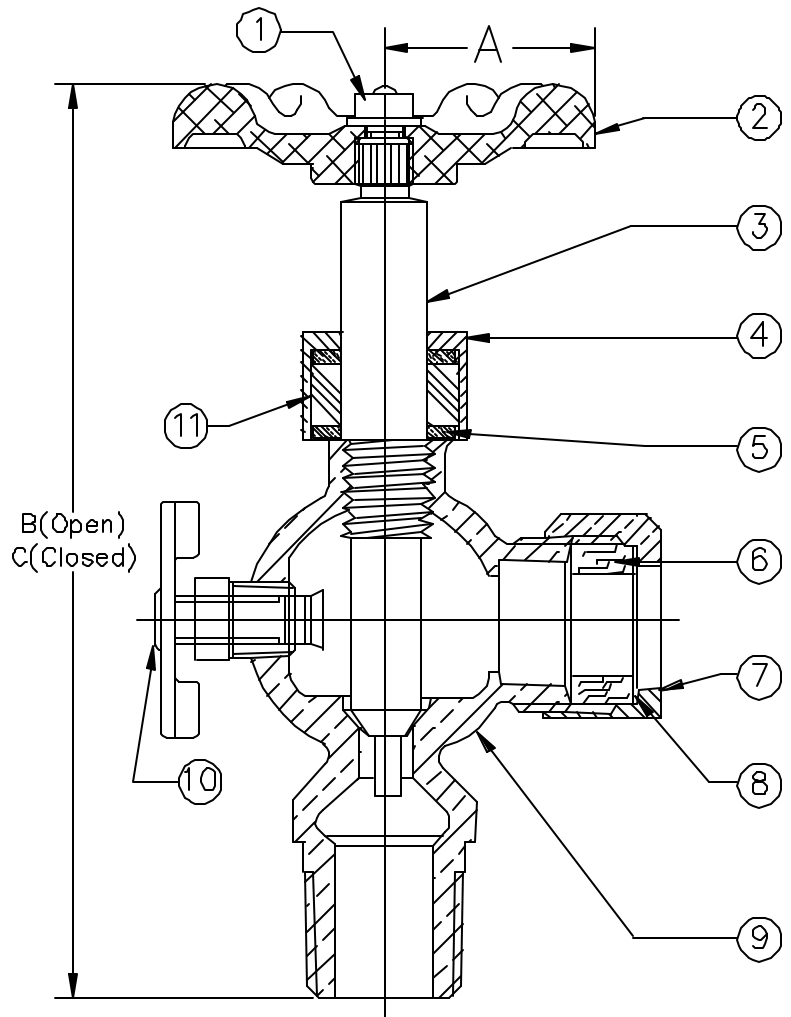

Size	1/2"
A	1.25
B	5.20
C	5.02
Ship Wt. (lbs.)	0.63
Qty. Per Carton	12