



UNITED BRASS WORKS, INC.
 714 S. Main St., Randleman, NC 27317
 Tel: 800-334-3035 Fax: 800-498-4696 www.ubw.com



Model 127TSB Sampler Valve

300 WOG • 100% Pressure Tested
Flanged Inlet x Threaded Inlet
PTFE Disc • Bronze Hand Wheel
Gasket Groove

MATERIAL LIST

NO.	DESCRIPTION	MATERIAL
1	Nut	Steel
2	Washer	Steel
3	Hand Wheel	Bronze
4	O-Ring Nut	Brass
5	O-Ring	Buna
6	Body	Bronze
7	Bonnet 1" Bonnet 2"	Brass Bronze
8	Stem & Disc Assembly	Brass
9	Gasket	Buna

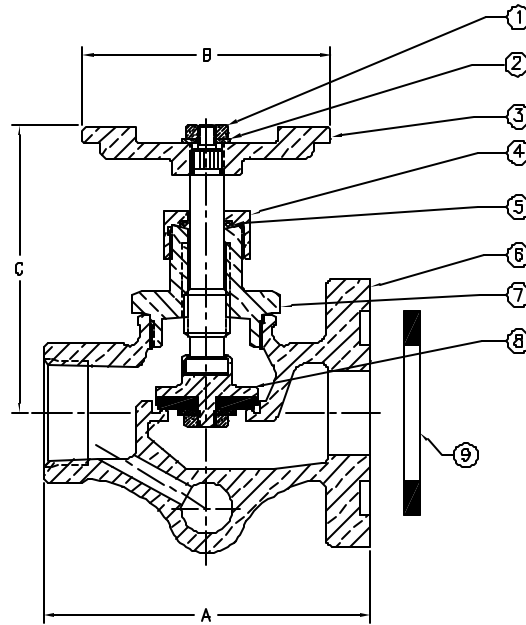

Size	A	B	C (Open)	C (Closed)	Bolt Circle	Bolt Hole	Weight
1"	3.81	2.94	3.75	3.31	3.13	0.625	4.10
2"	5.69	3.75	6.13	5.63	4.75	0.750	11.35