



UNITED BRASS WORKS, INC.

714 S. Main St., Randleman, NC 27317

Tel: 800-334-3035 Fax: 800-498-4696 www.ubw.com



Model 53 Check Valve

Full Flow Spring-Loaded Lift Check
Complies with MSS-SP-80-97

200WSP @ 406° Max

400 WOG

100% Pressure Tested

Threaded Ends • Solid PTFE Disc
Integral Seat

MATERIAL LIST

NO.	DESCRIPTION	MATERIAL
1	Bonnet Nut (1/4" - 3/8") Bonnet Nut (1/2" - 2")	Brass Bronze
2	Spring	Stainless Steel
3	Disc	PTFE
4	Body	Bronze
5	Guide (1/4" - 3/4") Guide (1" - 2")	Brass Bronze

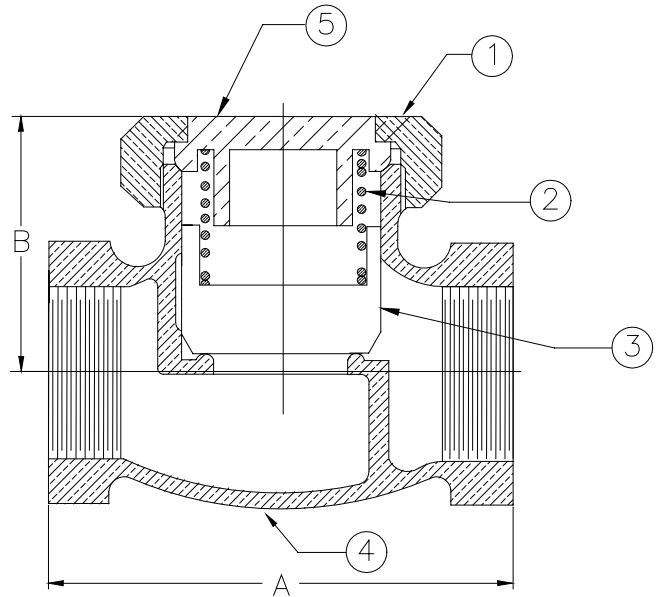

Size	1/4"	3/8"	1/2"	3/4"	1"	1 1/4"	1 1/2"	2"
A	2.19	2.36	2.59	3.17	3.75	4.28	4.78	5.88
B	1.19	1.50	1.88	1.81	2.06	2.38	2.63	3.25
Ship Wgt. (lbs.)	0.56	0.75	1.03	1.61	2.44	3.84	5.20	9.00
Qty. Per Ctn.	12	12	12	6	6	2	2	1