



UNITED BRASS WORKS, INC.
 714 S. Main St., Randleman, NC 27317
 Tel: 800-334-3035 Fax: 800-498-4696 www.ubw.com



Model 127TNG Sampler Valve

300 WOG • 100% Pressure Tested
Flange Inlet x Thread Outlet
ANSI Standard 150 Flange • No Gasket Groove
PTFE Disc • Aluminum Hand Wheel

MATERIAL LIST

NO.	DESCRIPTION	MATERIAL
1	Nut	Steel
2	Hand Wheel	Aluminum
3	O-Ring Nut	Brass
4	O-Ring	Buna
5	Body	Bronze
6	Bonnet 1" Bonnet 2"	Brass Bronze
7	Stem & Disc Assembly	Brass

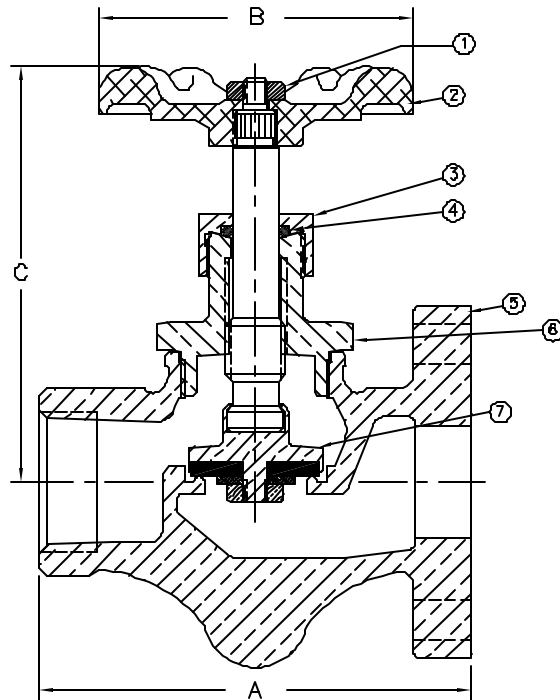

Size	A	B	C (Open)	C (Closed)	Bolt Circle	Bolt Hole	Weight
1"	3.81	2.94	3.75	3.31	3.13	0.625	3.93
2"	5.69	3.75	6.13	5.63	4.75	0.750	11.10