



UNITED BRASS WORKS, INC.

714 S. Main St., Randleman, NC 27317

Tel: 800-334-3035 Fax: 800-498-4696 www.ubw.com



Model 126MM Angle Valve

Metal to Metal Seat & disc

125 lbs. WSP @ 350 ° Max

200 lbs. WOG

100% Pressure Tested

Threaded Ends

Rising Stem

Swivel Disc Holder

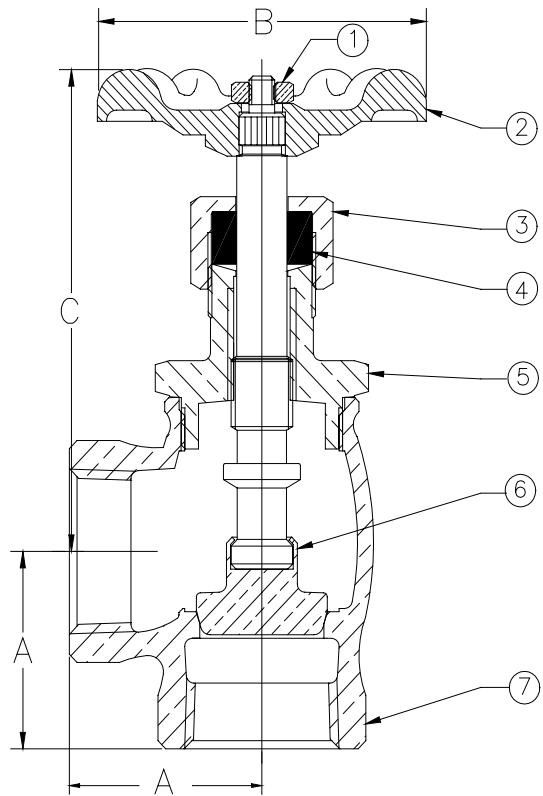

MATERIAL LIST

NO.	DESCRIPTION	MATERIAL
1	Hex Nut	Steel
2	Hand Wheel	Aluminum
3	Packing Nut	Brass
4	Packing	Graphite Non-Asb.
5	Bonnet (1/4" - 1") Bonnet (1 1/4" - 2")	Brass Bronze
6	Stem & Disc Holder	Brass
7	Body	Bronze

Size	1/4"	3/8"	1/2"	3/4"	1"	1 1/4"	1 1/2"	2"
A	0.84	0.94	1.09	1.22	1.47	1.75	2.00	2.34
B	1.75	1.75	2.03	2.38	2.75	3.00	3.72	3.72
C (closed)	2.63	3.00	3.13	3.25	4.38	4.50	5.25	5.63
Ship Wt. (lbs.)	0.44	0.56	0.69	0.94	1.76	2.50	3.26	5.32
Qty. Unit Pack	12	12	12	6	6	4	2	2
Qty. Per Case	60	60	72	60	36	24	12	12