

Auxiliary Finishing

ASF

Air Steam Finisher

Features

- Automatic Cycle with Adjustable Timers
- Vented Shoulder Forms
- Independent Foot Pedals for Blower and Steam Cycles
- Rugged Construction
- Large, Powerful Blower Motor
- Easy to Change Bag
- Dry Steam System
- Designed and Manufactured in USA

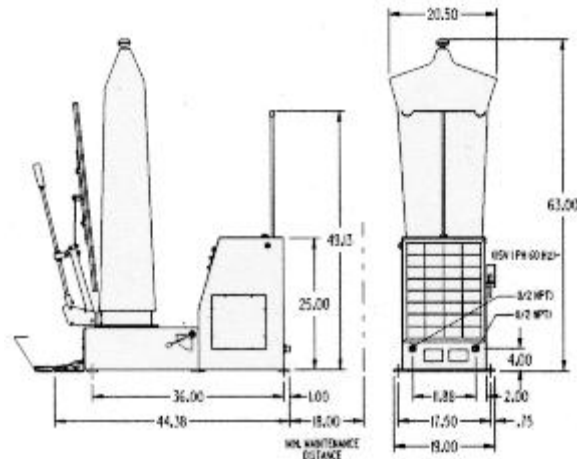

- Large Vacuum Area
- Fast Drying
- Removable Tip
- Rugged Construction
- Designed and Manufactured in USA

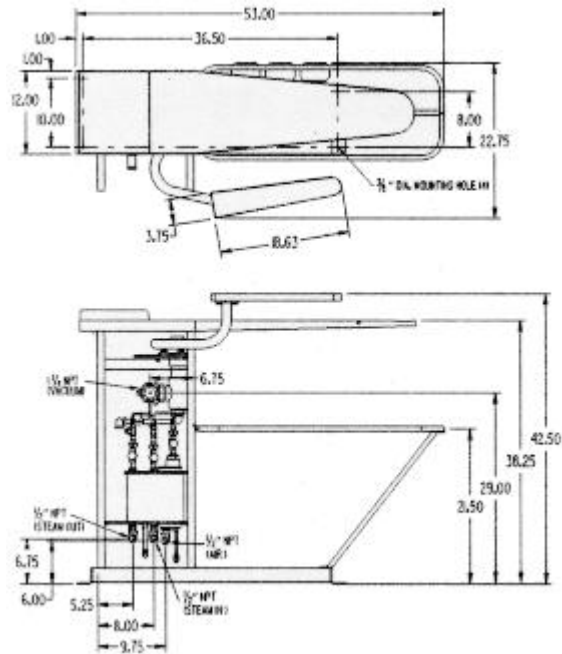

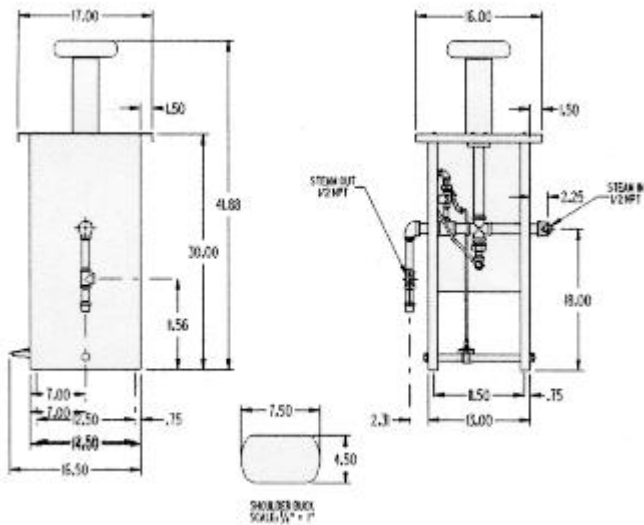

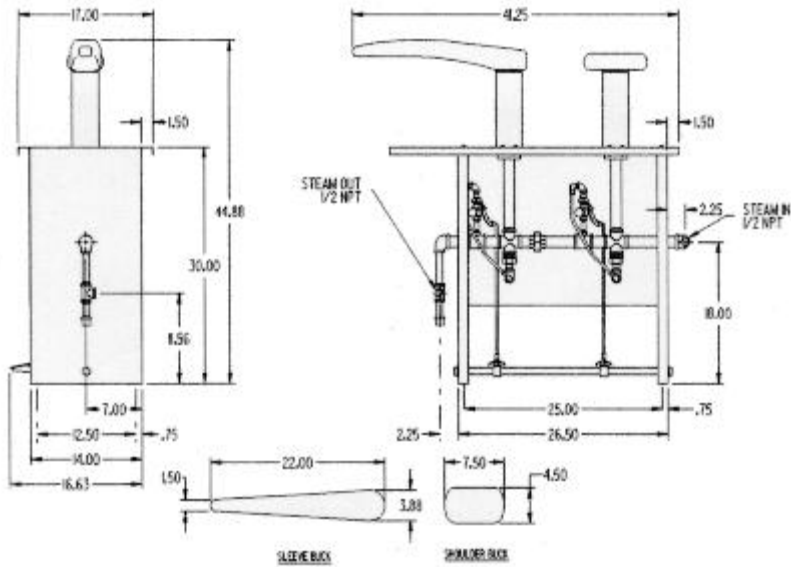

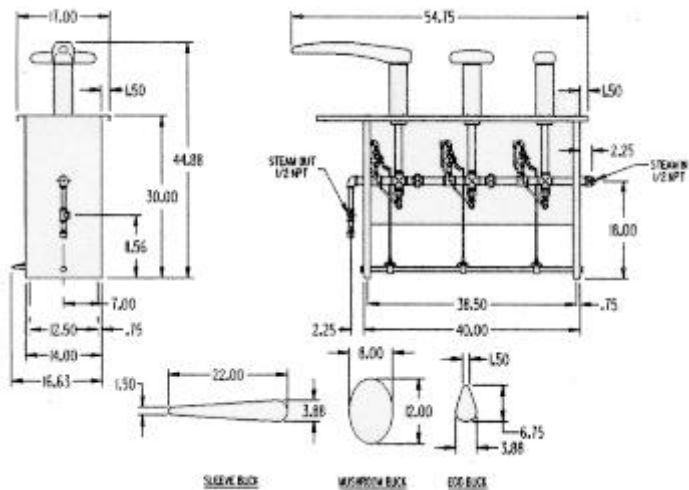

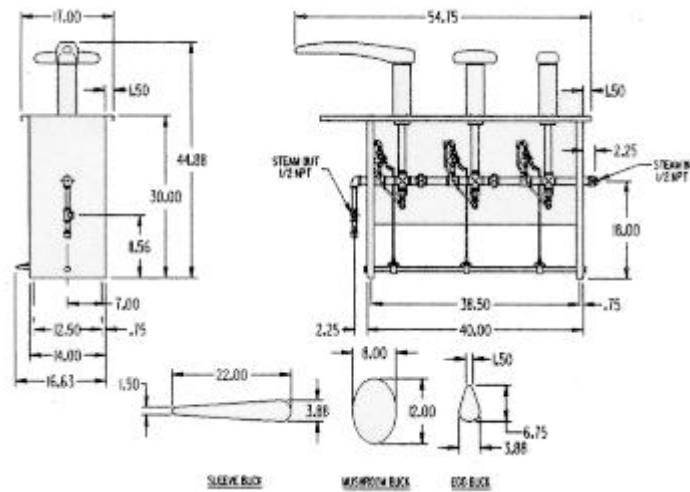

PI-3HV

Puff Iron (Egg, Mushroom and Sleever with Fabric heads and Vacuum)

Features

- Designed and Manufactured in USA
- Minimum floor space is required
- Durable Construction
- High Quality Valves



