



# **ABS JS-SERIES SUBMERSIBLE SLUDGE PUMPS.**

# ABS SUBMERSIBLE SLUDGE PUMPS

## Trouble free and safe handling

ABS dewatering pumps are equipped for immediate use. The slim design, encapsulated motor and no external moving parts makes installation and operation easy and safe.

## Non overloading performance

Flexible curve selection offers impeller with smaller diameter when you expect dry or snore running conditions. When half the motor is submerged (pump can operate lying down) you may choose the maximum impeller diameter for continuous duty.

## Easy service and maintenance

Common philosophy through the complete range with modular design and interchangeable spare parts. (For example identical shaft seals and shaft end on JS 24 to JS 84). Easy access to separate sealed electrical junction box. Easy to replace hydraulic parts such as impeller and volute.

## Plug-in start with motor protection

Built-in contactor, capacitor (Single Phase) and thermal protectors in the stator windings protects the motor and features an automatic restart function. This eliminates need for bulky external control boxes.

## Environmentally safe

The oil housing is filled with environmentally safe white oil. Non toxic coatings are used.

## High wear resistance

Impeller and pump housing are made in wear resistant ductile iron for maximum wear resistance and durability, extending the life of the pump. For extreme conditions choose ABS stainless steel vortex impellers.

## Solids handling capability

The JS sludge pumps are fitted with free flow vortex impeller and pump housing that provides great flows without clogging.

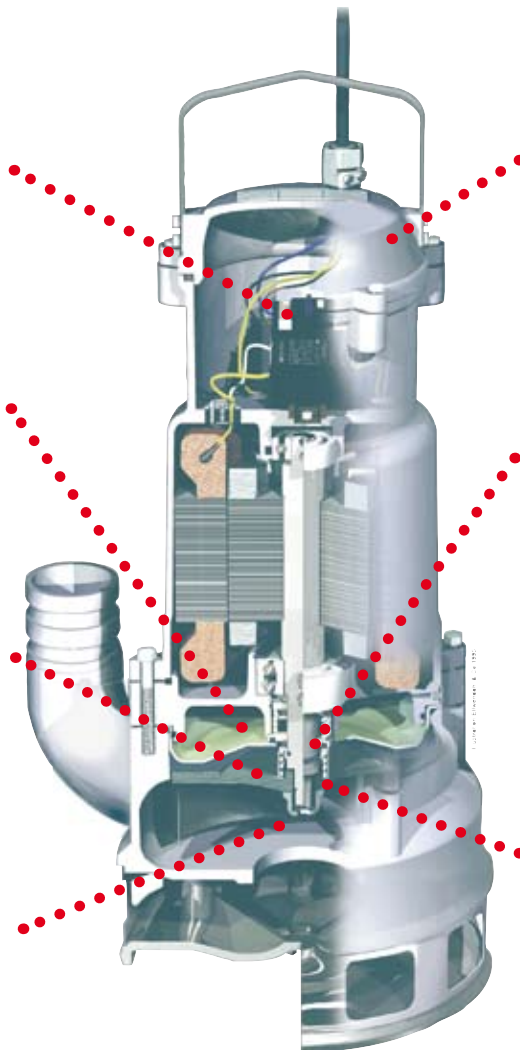

## Easy to move

Casted motorparts are made in light-weight aluminium alloy so the pump can easily be moved to the right location.

## High reliability

Double mechanical shaft seal in oil bath (silicon carbide on silicon carbide in the primary seal) for long life even under the most demanding running conditions.

Rigid stainless steel shaft and high quality ball bearings for vibration-free operation and long pump life.

## High flexibility

The pump can operate in any position, vertical or horizontal. The impellers are available in two various diameters to meet your specific pumping requirements.

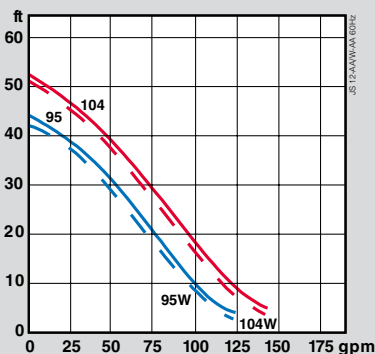

## ABS JS 12

JS 12 W -95  
JS 12 W/WKS\* -104  
JS 12 D -95  
JS 12 D/DKS\* -104

Rating (HP)  
Voltage (V)  
Full load (A)  
Speed  
Motor protection  
Power cable  
Free passage  
Discharge connection

Weight (excl. cable)

Single Phase  
Single Phase  
Three Phase  
Three Phase

1.5  
230 (Single Phase)  
6.6 (Single Phase)  
3360 rpm (Single Phase)  
built-in  
65 ft  
1 3/4" x 1 1/16"  
NPT 2", 3"  
Hose 2", 2 1/2", 3"  
40 lb

Dual 230/460 or 575 (Three Phase)  
3.8/1.9/1.5 (Three Phase)  
3400 rpm (Three Phase)

\* Built in float switch available as option.

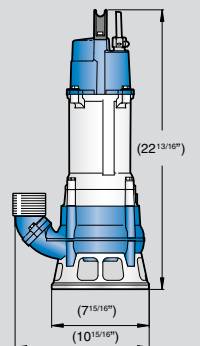

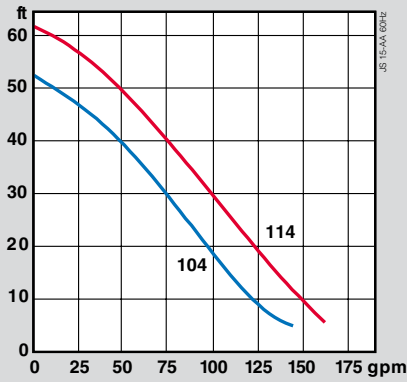

## ABS JS 15

**JS 15D -104**  
**JS 15D/DKS\* -114**

Rating (HP)  
Voltage (V)  
Full load (A)  
Speed  
Motor protection  
Power cable  
Free passage  
Discharge connection

**Three phase**  
**Three phase**  
2  
Dual 230/460 or 575  
5.2/2.6/2.1  
3400 rpm  
built-in  
65 ft  
1<sup>3</sup>/<sub>4</sub>" x 1<sup>1</sup>/<sub>16</sub>"  
NPT 2", 3"  
Hose 2", 2 1/2", 3"  
40 lb

Weight (excl. cable)

\*Built in float switch available as option.

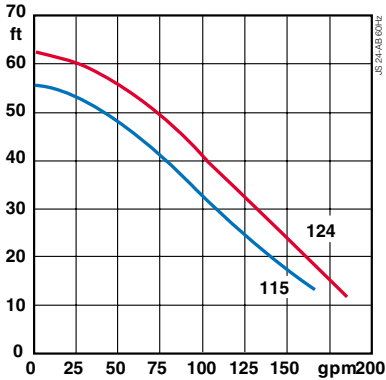
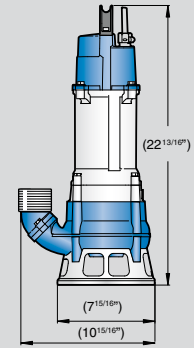

## ABS JS 24

**JS 24D/DKS\* -115**  
**JS 24D/DKS\* -124**

Rating (HP)  
Voltage (V)  
Full load (A)  
Speed  
Motor protection  
Power cable  
Free passage  
Discharge connection

**Three phase**  
**Three phase**  
3  
Dual 230/460 or 575  
8/4/3.2  
3400 rpm  
built-in  
65 ft  
2<sup>3</sup>/<sub>16</sub>" x 1<sup>1</sup>/<sub>16</sub>"  
NPT 3", 4"  
Hose 2 1/2", 3", 4"  
64 lb

Weight (excl. cable)

\*Built in float switch available as option.

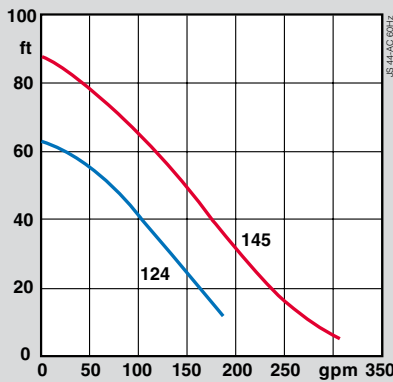
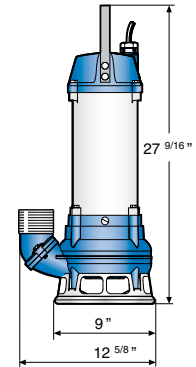

## ABS JS 44

**JS 44D/DKS\* -124**  
**JS 44D/DKS\* -145**

Rating (HP)  
Voltage (V)  
Full load (A)  
Speed  
Motor protection  
Power cable  
Free passage  
Discharge connection

**Three phase**  
**Three phase**  
5  
Dual 230/460 or 575  
14/7/5.6  
3400 rpm  
built-in  
65 ft  
2<sup>3</sup>/<sub>16</sub>" x 1<sup>1</sup>/<sub>16</sub>"  
NPT 3", 4"  
Hose 2 1/2", 3", 4"  
79 lb

Weight (excl. cable)

\*Built in float switch available as option.

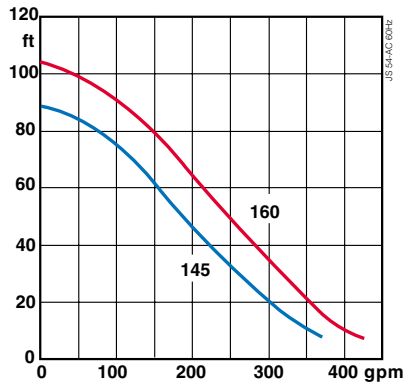
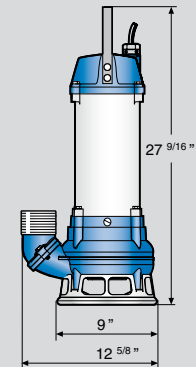

## ABS JS 54

**JS 54D-145**  
**JS 54D-160**

Rating (HP)  
Voltage (V)  
Full load (A)  
Speed  
Motor protection  
Power cable  
Free passage  
Discharge connection

**Three phase**  
**Three phase**  
8  
Dual 230/460 or 575  
22/11/8.8  
3400 rpm  
built-in  
65 ft  
2<sup>3</sup>/<sub>16</sub>" x 1<sup>3</sup>/<sub>4</sub>"  
NPT 3", 4"  
Hose 3", 4"  
119 lb

Weight (excl. cable)

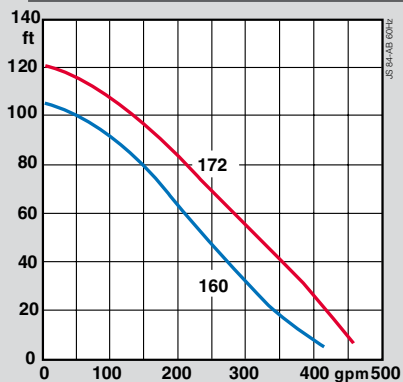
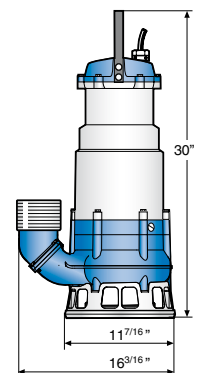

## ABS JS 84

**JS 84D-160**  
**JS 84D-172**

Rating (HP)  
Voltage (V)  
Full load (A)  
Speed  
Motor protection  
Power cable  
Free passage  
Discharge connection

**Three phase**  
**Three phase**  
12  
Dual 230/460 or 575  
30/15/12  
3400 rpm  
built-in  
65 ft  
2<sup>3</sup>/<sub>16</sub>" x 1<sup>3</sup>/<sub>4</sub>"  
NPT 3", 4"  
Hose 3", 4"  
148 lb

Weight (excl. cable)

