

# Legal-for-Trade Smart Dumper™

for accuracy, accountability, and economy

The "Smart Dumper System" combines a legal-for-trade weighing system and an easy-to-operate, hydraulic cart dumping unit. It incorporates the accuracy and durability of the LTS scale with the quality and reliability of an Ameri-Kart dumping system.

## NTEP Approved Weighing System:

The weighing system in the Smart Dumper is the only unit of its type to receive National Type Evaluation Program (NTEP) approval on a dumper/scale combination for refuse collection. A legal-for-trade designation enables the hauler to charge by accurate weight, not container size.

## Accuracy:

The LTS system has a guaranteed accuracy of 0.1% of capacity that prevents overload fees and charge disputes between haulers and waste generators.

## Options:

For access control and individual user activity records, the Smart Dumper can be ordered with an RFID reader, or bar code reader, or printer, or port for hard wire data transmission to a PC.

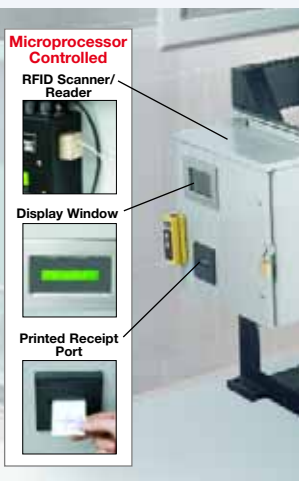

## Specifications:

Footprint:  
 H 49-1/2 x W 42 x D 36-1/2"  
 Clearance required for use with One-Yard Cart:  
 Overhead 132"  
 Horizontal 93"  
 Capacity:  
 500 lbs. (legal-for-trade approved)  
 1000 lbs. units available  
 Shipping Weight:  
 Approx. 1000 lbs.

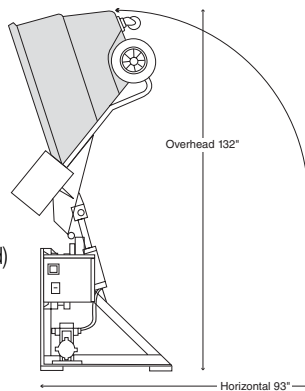

The standard Smart Dumper is equipped with an AC power supply, audio or visual alarm, and an accumulator to monitor total container weight.



Precision load-cell for weighing accuracy.