

PRINT

E-12

If elevators help move you around, the E-12 will give your efficiency a lift.

Compact design allows the E-12 to fit in tight corners. A traveling speed of 7 mph lets it transport you and your stock twice as fast as by foot! Save four hours over every eight hours of walking work, and increase your time for value-added service!

The E-12 features durable steel construction and a loading platform for a range of applications.

Benefits

RANGE OF APPLICATIONS:

- Mail delivery.
- Maintenance.
- Order picking.
- Supervision.
- Plant security.
- First aid.

MOTREC
Industry driven
www.motrec.com



E-12

Dimensions

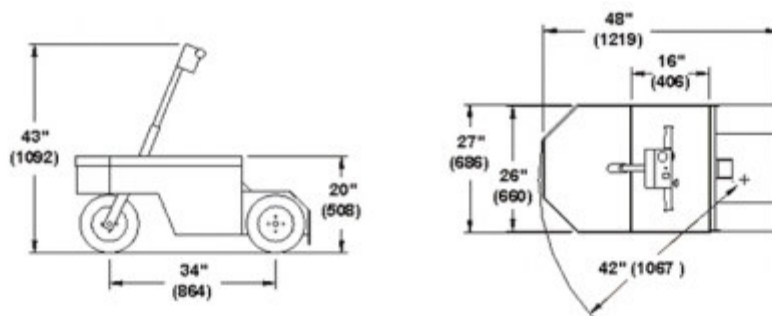

Technical specs	
Type	24-volt personnel carrier
Capacity	*300 lb. (227 kg)
Speed (Max)	7 mph (11 km/h)
Motor	1 hp
Controller	Electronic speed controller, twist grip throttle handle
Battery	Two 12V-105AH batteries
Charger	15 amp, built-in automatic
Transmission	V-Belt drive, chain reduction
Drive axle	Front-wheel drive
Brakes	Dual drum brakes on rear, brake pedal.
Steering	Handlebar
Suspensions	Rigid axles on front and rear
Seats	N/A
Indicators	Battery status indicator
Safeties	Optional reverse alarm and deadman foot switch
Lights	Head light
Accessories	Horn
Wheels	4.1x6 LRB pneumatic tires
Unit Weight	320 lb. (145 kg)
Options	Reverse alarm and deadman foot switch. Slide-out or lift-out battery box. Digital battery status indicator. Hour meter. Maintenance meter. Strobe light.
Standard	Conforms to requirements for type E as stated in UL 583 and ANSI B56.8
Notes	*includes 200 lb. per passenger. Specifications and standard equipment are subject to change without notice.



MOTREC
Industry driven
www.motrec.com