

# GO ANYWHERE DO ANYTHING

SCOUT SC-50 TRACKED UTILITY VEHICLE



**ASV**



# THERE ARE NO BOUNDARIES

At home, on a jobsite, working your ranch or grooming trails, the Scout can take you there like no other vehicle. This unique utility machine treks through virtually any ground conditions - even where others only spin their wheels. Roam the woods or criss-cross pristine landscaping - with the Scout, you can travel in style and not leave a trace.

At work or play the Scout makes traveling enjoyable. The operator and passenger ride in a comfortable, spacious compartment that can be outfitted to suit your personal needs.

The Scout comes ready to tackle serious work. Its 50-horsepower diesel engine, hydrostatic drive system and rubber track undercarriage come from ASV's legendary Posi-Track™ Loaders. With a generous fuel capacity, you can travel with confidence into remote locations not accessible any other way.

Outfit the Scout with a hydraulically-operated dump box for productive material hauling. Or use the rear deck for transporting cargo. There's plenty of room and capacity to mount the tools, attachments or equipment you need for special applications. Add the optional auxiliary power system and you get powerful hydraulics and quick-connect fittings at the front bumper and behind the operator station.

*THE POSSIBILITIES ARE UNLIMITED*

# SAFE, EASY AND COMFORTABLE

The Scout gives you and a passenger plenty of room while comfortable contoured seats help the miles pass quickly. Two-inch wide seat belts and grab handles keep you safely in place when negotiating rough terrain. A certified Roll Over Protection Structure (ROPS) is standard.

Steering the Scout is effortless and control is precise. Unlike other tracked vehicles, the Scout uses a steering wheel so driving is as natural as in your car.

An innovative Quick-Shift™ pedal makes operation even easier. Push the right side to go forward and the left side for reverse. It's the quickest and simplest way to travel. The drive system is fully hydrostatic; braking is automatic.

Standard convenience features include two 12V power ports, two cupholders and over 1,000-in<sup>3</sup> of personal storage space under the driver's seat.

Optional features for the operator station include a fully-enclosed cab with locking doors, heater, a tilt-out windshield and a choice of canopies.



# POWER AND TRACTION TO GO ANYWHERE

The Scout can take you places that might surprise you. It has the power and traction to go virtually anywhere and an extended travel range to get you there and back.

The Scout is powered by a reliable 50-horsepower Perkins 404C-22 diesel engine. A Posi-Power™ power management system helps the engine work in harmony with the machine's hydraulic system, reducing the chance of engine stall, even under peak loads.

The Scout's rubber tracks are hydrostatically-driven by a sprocket and free-turning, low-friction rollers. Rollers engage lugs inside the track to drive the track forward and reverse with smooth, efficient and reliable power.

Twenty-four rollers in the Scout's undercarriage distribute its weight throughout the length and width of the tracks. This translates to a mere 2.5 pounds per square inch (psi) ground pressure under the tracks - *about half the psi of a person on foot*. This lets the Scout travel over soft, wet conditions where you couldn't even walk.

On turf, landscaping and other sensitive surfaces, the Scout's low ground pressure lets you work without causing damage, making it ideal for landscapers, arborists and others who work on or near sensitive, fragile environments.

The Scout also has incredible traction - enough to pull 5,000-lb. That's far more towing capacity than any 4x4 or 6x4 utility vehicle. Torsion axles suspend the undercarriage to absorb bumps and keep tracks on the ground. As a result, there's more traction and a softer ride for passengers and cargo.

Not only can the Scout take you where other vehicles cannot - it takes you further. With a 30-gallon fuel capacity, the Scout runs all day. That makes the Scout the ideal vehicle to penetrate deep into territories not normally accessible by ground.

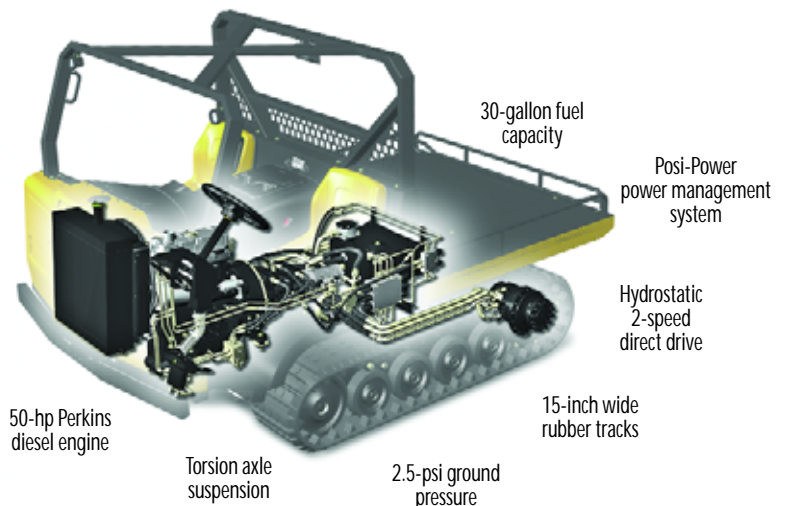

50-hp Perkins diesel engine

Torsion axle suspension

30-gallon fuel capacity

Posi-Power power management system

Hydrostatic 2-speed direct drive

2.5-psi ground pressure

15-inch wide rubber tracks

# VERSATILE ENOUGH TO DO ANYTHING

The Scout's 24-ft<sup>2</sup> of cargo space handles up to 2-tons of payload. Use it to haul virtually anything. Bolt-on side rails are available to keep loads stabilized when traveling over rough terrain.

The Scout can be factory-fitted with a hydraulically-operated dump box with a 1.3 yd<sup>3</sup> heaped capacity - even more when side boards are added. You can haul and dump more than 3,200-lb of material without leaving the operator seat. And you can remove or install the dump box in well under an hour using a fork lift.

Use the rear deck to customize the Scout to do anything you want. Front and rear auxiliary hydraulics are available and include quick-connect coupler fittings and variable flow up to 16.3 gallons per minute (gpm) at 3,000 psi. That's up to 28 hydraulic horsepower to run a wide range of hydraulic tools and attachments. Power to attachments is controlled from the operator seat by a center console-mounted low-effort joystick.

A front-mounted snow blade also is available. It features full power for up, down, angle and float

positions. Combine the snow blade, the Scout's incredible traction, and hauling capacity for a world-class snow removal system.



# CUSTOMIZE A SCOUT OF YOUR OWN



1.3 yd<sup>3</sup> Hydraulic Dump Box Option



Turf Edition with Smooth Tracks



Brushguard

The Scout comes well-equipped to handle a wide range of tasks in a wide range of conditions. Or outfit the Scout with available options to fit your own requirements.

## Standard Equipment

---

- Air cleaner, dual-stage
- Alternator, 65-amp
- Battery, 770 CCA
- Brake, parking
- Electrical system, 12-volt
- Engine, Perkins 404C-22
- Final drive, direct hydrostatic
- Fuse box, automotive style
- Heater, engine block
- Hitch receivers, front and rear
- Ignition switch, key
- Operator presence switch
- Roll Over Protection Structure - ROPS
- Rubber track undercarriage, 15-inch wide tracks
- Throttle, hand-operated
- Tie-down loops, front and rear
- Transmission, hydrostatic
- Seat belts, 2-inch wide
- Storage compartment
- Working lights - two front, one rear
- Warning lights:
  - coolant temp
  - engine oil pressure
  - hot hydraulic oil
  - low battery

## Optional Equipment

---

- Auxiliary hydraulics - 16.3 gpm
- Back-up alarm
- Beacon, rotating
- Bed rails
- Brushguard
- Bumper, front
- Cab enclosure
- Canopy and rear window
- Dump box, hydraulic, 1.3 yd<sup>3</sup> capacity
- Horn
- Heater
- Turf Edition with turf-friendly smooth tracks
- Windshield, tilt-out
- Work attachments (consult your ASV Dealer for the full line of attachments available)

# Specifications and Dimensions

## Power Train:

Engine	Perkins 404C-22
Type	Diesel
Displacement	134 in <sup>3</sup> / 2.2 Liters
Cylinders	4, In-Line
Gross power @ 2800 rpm	50 hp / 37.3 kW
Net power @ 2800 rpm	46 hp / 34.3 kW
Torque, peak	105 ft-lbs / 143 Nm

## Machine Weight:

Shipping weight	4,220 lb / 1914 kg
Operating weight	4,562 lb / 2069 kg
Ground pressure:	
@ Shipping weight	2.38 psi / 16.4 kPa
@ Operating weight	2.56 psi / 17.6 kPa

## Operating Specifications:

Bed capacity:	4,000 lb / 1814 kg
Gross vehicle weight:	9,000 lb / 4082 kg
Maximum speeds:	
Low range	6.5 mph / 10.5 kmh
High range	11.5 mph / 18.5 kmh

## Auxiliary Hydraulic System:

Maximum flow	16.3 gpm / 61.7 lpm
Maximum system pressure	3,000 psi / 20 670 kPa

## Undercarriage Specifications:

Track width	15 inches / 381 mm
Track length on ground	59 inches / 1499 mm
Ground contact area	1,770 inches <sup>2</sup> / 1.14 m <sup>2</sup>
Suspension	Torsion bars (4)

## Steering System:

Type	Hydraulic
Control	Steering wheel
Lock-to-lock	330°
Minimum turning radius	64 in. / 1626 mm

## Capacities:

Fuel tank	30 gallons / 113.5 liters
Hydraulic system	10 gallons / 37.9 liters
Engine coolant	2 gallons / 7.6 liters
Engine oil, including filter	2.8 gallons / 10.6 liters

## Dump Box:

Box volume, heaped	1.3 yards <sup>3</sup> / .99 meters <sup>3</sup>
Box volume, struck	1 yard <sup>3</sup> / .76 meters <sup>3</sup>
Bed height, loaded	26 inches / 660 mm
Bed height, unloaded	28 inches / 711 mm
Box maximum load	3,298 lb / 1496 kg

*Machines featured in photos/illustrations may include additional equipment. Specifications, standard features and optional equipment are subject to change without notice. Consult your ASV Dealer for details.*

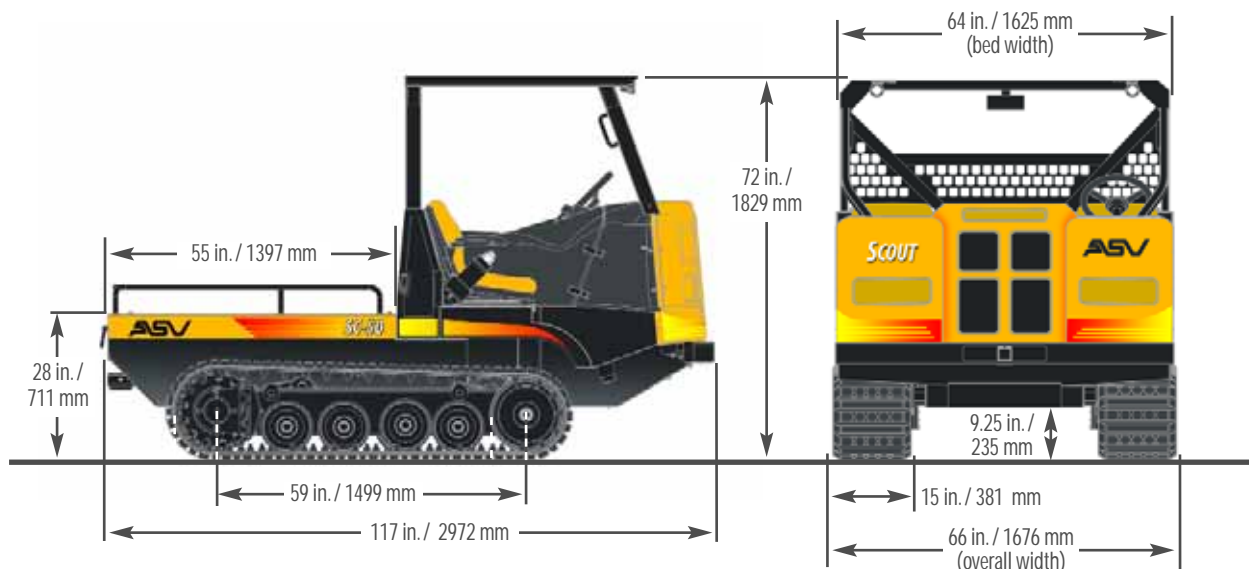



## TIME-PROVEN TRACK RECORD

**The Scout is new.** The patented technology that makes the Scout so versatile has been around for a long time. In fact, ASV equipment has run on suspended rubber tracks for nearly 25 years. The power train, undercarriage and tracks on the new Scout have been on Posi-Track loaders for years working in rough, demanding construction applications. It's a field-proven design that stands up to long hours of hard work and harsh environments.

Your ASV Dealer also stands behind the Scout. With more than 300 ASV Dealers worldwide, you probably have one close to you. Each ASV Dealership is committed to bringing you the best rubber-tracked equipment available, along with superior customer support to keep you moving at full speed.

For more information about the Scout, contact your ASV Dealer. You can find your closest dealer on [www.ASVI.com](http://www.ASVI.com).

A.S.V., Inc.  
840 Lily Lane  
Grand Rapids, MN 55744  
800.346.5954 • [www.ASVI.com](http://www.ASVI.com)

© 2007 A.S.V., Inc.  
ASVSC002 (06/07)