

STELLAR AGGRESSOR™

1302 Mini OTR



The 1302 OTR Series is a tire service truck for multi-purpose use. It is the ideal, multi-functional tire service truck capable of meeting any size commercial truck and mini-OTR tire dealer's needs. It offers a greater payload, larger capacity and state-of-the-art components as a result of extensive field research.

This industry proven 13' aluminum body centers around an advanced use of design and materials. With a standard body weight of approximately 1000 pounds, maximized payload and better fuel economy are easily realized. The 43" high x 96" wide body is designed to hold 3 rows of 8 standard truck tires. The 1302 OTR's sub-structure is based around the industry proven extruded aluminum plank floor. It was designed to be stronger, more durable, and longer lasting than a flat sheet of deck plate commonly found on most tire service bodies.



The 1302 OTR truck is mounted on a chassis cab with a 108" cab to axle and can be equipped with either a model 2200 or 3200 hydraulic knuckleboom crane. Both of these cranes are designed to handle the largest of farm tires and the smaller sized OTR tires. These cranes are both operated by a standard fully proportional radio remote control.



The driver-side front vertical cabinet has standard 3/8" x 50' and 1/2" x 50' hose reels along with an air filter and regulator mounted to the top of the compartment for ease of accessibility. Options available include a 2-drawer cabinet with a 15-pin socket rack and compartment lights.

Stellar's EDL-16-86 1600-pound all-hydraulic liftgate with a galvanized grip-strut platform and folding rail tire stop is optional. Top mounted stop, tail and turn lights are used for greater visibility and safety and are standard equipment. (Shown are the optional strobes).

STELLAR AGGRESSOR™ 1302 Mini OTR

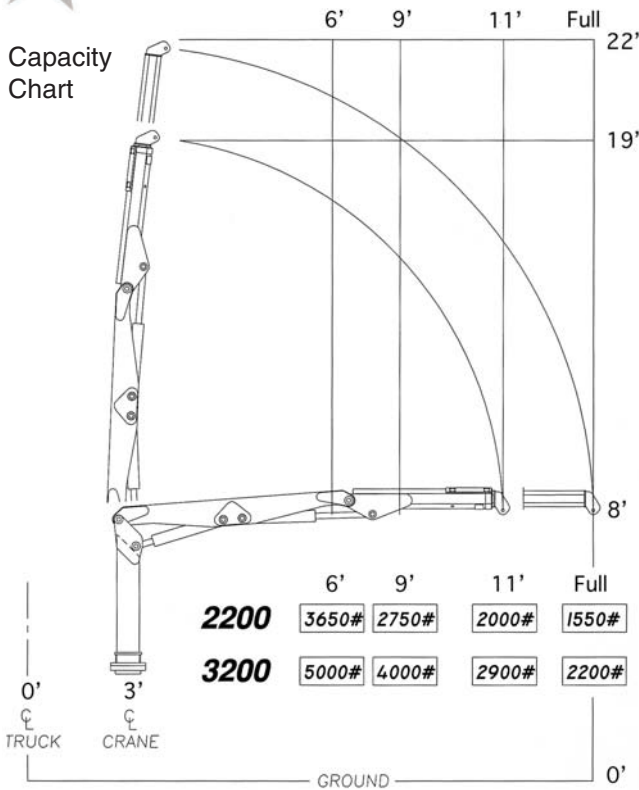

Above is a 26" vertical cabinet as shown from the passenger's side. Note the large adjustable shelves and the heavy-duty reinforced door design with stainless steel hinges. All door hardware is bolted on with stainless steel bolts and lock nuts. The optional road service strobe light is located on the top of the crane.

Also included are rounded automotive style wheel wells with rubber trim and standard halogen low level built-in flood light on both left and right sides.

Specifications	2200	3200
Crane Rating	22,000 foot/pounds	32,000 foot/pounds
Boom Extension	Hydraulic 32 inches	Hydraulic 32 inches
Max. Horizontal Reach	14 foot-from CL of Crane	14 foot-from CL of Crane
Rotation	320 degree power (worm gear drive)	290 degree power (worm gear drive)
Lifting Capacities (from CL of truck)	3,650 lbs. @ 6 foot 2,750 lbs. @ 9 foot 2,000 lbs. @ 11 foot 1,550 lbs. @ Full	5,000 lbs. @ 6 foot 4,000 lbs. @ 9 foot 2,900 lbs. @ 11 foot 2,200 lbs. @ Full
Power Supply Required	PTO & Pump (4 gpm @ 2800 psi)	PTO & Pump (4 gpm @ 2800 psi)
Controls	Proportional Radio Control Standard	Proportional Radio Control Standard
Stowed Height (above truck frame)	65 inches	67 inches
Mounting Space Req.	24 inches	24 inches
Approx. Shipping Weight	1,350 lbs.	1,900 lbs.



The SHD-66DD direct-driven hydraulic-drive air compressor is mounted to a 20-gallon air tank on the crane base. This compressor has a 46 CFM at 175 PSI output. The location allows for cool, clean, fresh air intake, and easy maintenance and serviceability. The SHD-66DD carries a 2-year warranty because of these features.



280 West Third Street
 Garner, Iowa 50438
 1-800-321-3741
 Fax: 641-923-2812
 E-mail: sales@tiretruck.com
 www.tiretruck.com

Designed & Manufactured in the U.S.A.

*Specifications may change without notification.
 Copyright © 2004 Stellar Industries, Inc.