

# Harris

## *H562 Series Shear/Logger/Baler*

Model H562DT Diesel  
Transportable Shown



### Processes:

Selected #1 & #2 Scrap

Misc Light Scrap

Shapes

Auto Body Parts

White Goods

Pipe

**H562DT Diesel Transportable  
Shear/Logger/Baler**

**H562SE Stationary Electric  
Shear/Logger/Baler**



# Harris

200 Clover Reach Dr  
Peachtree City, GA 30269

(800) 373-9131  
(770) 631-7290

(770) 631-7299 FAX  
[www.harriswaste.com](http://www.harriswaste.com)

# Harris H562 Series

## Shear/Logger/Baler

|  |   |
|--|---|
| Box Open Dimensions  | 236"L x 95"W x 39"D (6000mm x 2400mm x 990mm)                               |
| Box Closed Dimensions  | 236"L x 35"W x 24"D (6000mm x 880mm x 600mm)                                |
| Shear Throat   | 37"W x 25"H (940mm x 635mm)   |
| Shearing Force   | 520 tons (470 tonne)  |
| Clamp Force  | 99 tons (90 tonne)  |
| Shearing Capacity  | Mild Steel Plate 2 1/4" x 34" (57mm x 864mm)                                |
| Production Rate (shearing)   | Up to 16 tons/hr (14.5 tonne/hr)  |
| Cuts per Minute  | Up to 5.5 crosshead only (empty). 4 @ 24" feed length, with clamp, unloaded |
| Side Force   | 253 tons, each side (230 tonne)   |
| Baling Force   | 150 tons (136 tonne)  |
| Bale Size  | 35"W x 24"H x V (880mm x 600mm x V)   |
| Bale Density   | 60 - 85 lbs/cu ft. (960 - 1400 kg/cu meter)                                 |
| Bale Weight (average)  | 880 lbs. (400 kg)   |
| Log Density  | 25 - 40 lbs/cu ft. (400 - 640 kg/cu meter)                                  |
| Log Weight (average)   | Up to 1600 lbs (730 kg)   |
| PERFORMANCE RATES, BALE WEIGHTS, AND BALE DENSITIES ARE SUBJECT TO MATERIAL PRE-BALE DENSITIES, FEED RATES, AND OTHER VARIABLES IN BALING. |   |
| Production Rate (baling)   | 20 - 30 bales/hr. Up to 13 tons/hr  |
| Production Rate (logging)  | Up to 16 tons/hr.   |
| 562DT-Diesel Engine  | (1) 214 HP, @ 1800 RPM (160 kw)   |
| 562DT-Diesel Fuel Capacity   | 80 gallons (300 Liters)   |
| 562SE Electric Motor   | 200 HP 3/60/480v  |
| Main Pump  | Pressure-compensated, Torque-limited piston & heavy-duty vane               |
| Shear Cylinders  | (2) Maximum Force 520 tons (471 tonne) (260 tons each) (236 tonne)          |
| Clamp Cylinder   | (1) Maximum Force 99 tons (90 tonne)  |
| Feed Cylinder  | (1) Maximum Force 150 tons (136 tonne)                                      |
| Side Compression Cylinders   | (4) Maximum Force 506 tons (460 tonne) (253 tons each side) (230 tonne)     |
| 562DT-Lifting Cylinders  | (4) Maximum Force 80 tons (total) (73 tonne)                                |
| Oil Reservoir  | 530 gallon capacity (2000 liters)   |
| Hydraulic Oil Filtration   | 5 & 10 micron replaceable cartridge   |
| Gross Weight   | 62 tons, approx. (56 tonne approx.)   |

M00003

revised 9/04

Specifications subject to change without notice.

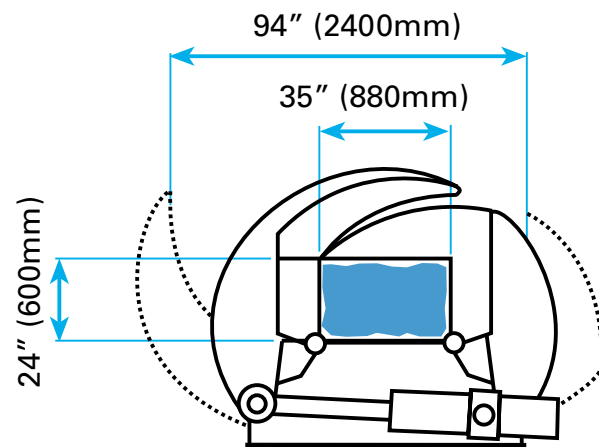
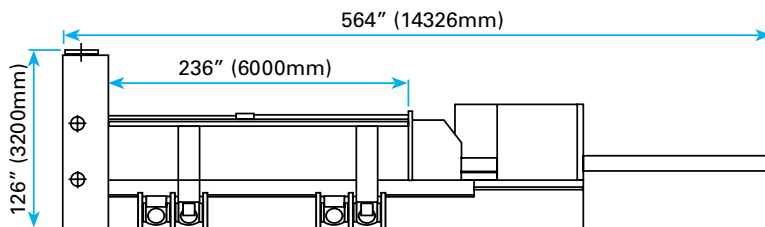

200 Clover Reach Drive  
 Peachtree City, GA 30269  
[www.harriswaste.com](http://www.harriswaste.com)  
 770-631-7290  
 800-373-9131  
 770-631-7299 fax