

RC-30

TURF EDITION™

Posi-Track™

Rubber Track Loader



The RC-30 Turf Edition is a special version of ASV's most compact Rubber Track Loader. It was designed specially for turf professionals for use on golf courses, parks and other turf surfaces. It's the ideal alternative to small skid steer loaders, small 4-wheel drive tractors and compact walk-behind equipment.

The RC-30 Turf Edition is compact enough to travel and work where other ride-on machines cannot, yet versatile and productive enough to

replace an entire crew of hand labor.

Tracks on the RC-30 Turf Edition have a unique smooth surface that lets you travel and work on turf without leaving a trace. You have the traction needed to work productively in most conditions.

Unique, patented undercarriage technology lets the RC-30 crawl over virtually any surface with only 2.8 psi ground pressure. The 11-inch wide green rubber tracks give exceptional traction and stability for tough earth-

moving applications. The undercarriage also includes suspension for a smooth, stable ride.

A broad selection of performance-matched Posi-Tool™ attachments for the RC-30 assure maximum versatility and productivity in all applications. This makes the RC-30 Turf Edition ideal for new construction and reconstruction projects, plus daily and seasonal maintenance tasks.

Horsepower: 31.5 HP / 23.5 kW

Operating Weight: 3,305 lb / 1500 kg

Ground Pressure: 2.8 psi / 19.3 kPa



A compact, low-impact loader designed for turf RC-30 Rubber Track Loader,



Turf-friendly Rubber Tracks

Smooth rubber tracks set the RC-30 Turf Edition apart from all other equipment. These unique patent-pending tracks enable the RC-30 to work hard in tough conditions, yet make it virtually impossible to scuff or damage sensitive turf surfaces. That gives you the best of both worlds - *not something you get from a wheeled machine.*

Twenty-four rubber wheels spread the RC-30's weight evenly over the 11-inch wide rubber tracks. As a result, there is only 2.8 psi ground pressure - *about half the ground pressure of a person on foot.* This light footprint

reduces soil compaction and helps prevent damage to anything underground such as root systems and irrigation water lines.

There is no steel inside ASV rubber tracks. An internal positive drive

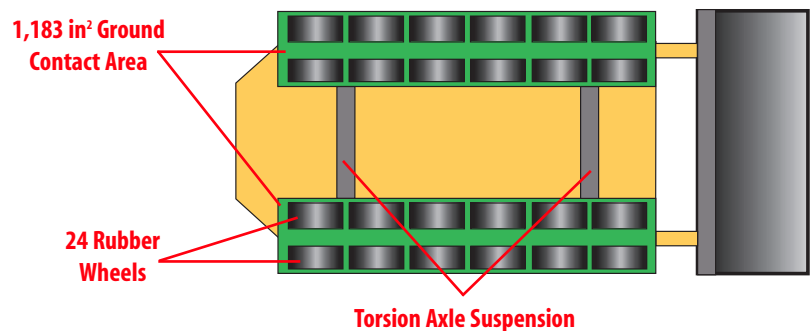

professionals. TURF EDITION.

system uses hydrostatically-driven sprockets with free-turning rollers to engage drive lugs inside the track. Operation is smooth, quiet and very efficient.

Torsion axle suspension of the undercarriage is another ASV exclusive. Suspension helps maximize contact with the ground for better traction and stability. It also gives a much smoother ride for the operator, improves load-retention and is easier on the machine, too.

Easy, Comfortable Operation

The RC-30's operator station is designed for comfort and control. For such a compact machine, the RC-30 offers a surprisingly roomy and comfortable operator station. No foot controls mean plenty of leg room and less operator fatigue. For work in tight and confined areas, the RC-30 offers excellent all-around visibility.

Ergonomic controls include pilot-operated implement and propel levers. A full spectrum of gauges and

switches are conveniently located in the heads-up position for easy view and reach. Safety-related features include full ROPS/FOPS canopy, lap bar, comfortable seat belt and brake. An enclosed cab is also available with a sound insulation package.

Powerful, Reliable Powertrain

The RC-30 Turf Edition is powered by the Perkins 403C-15 - a tough, reliable 1.5 liter 3-cylinder diesel engine.

Attachments for Every Application

The RC-30 comes ready to take on a wide variety of performance-matched attachments. The line of ASV Posi-Tool™ attachments for the RC-30 include augers, buckets, rakes, mowers, sod-laying equipment and many more.

Available Machine Configurations

The ASV RC-30 , RC-50 and RC-60 are available in Turf Edition configurations. You can also get these models, plus the larger Posi-Track Loaders, in the standard configuration that includes black rubber tracks with treads for added traction in wet, slippery ground conditions.



RC-30 TURF EDITION

Posi-Track™ Rubber Track Loader

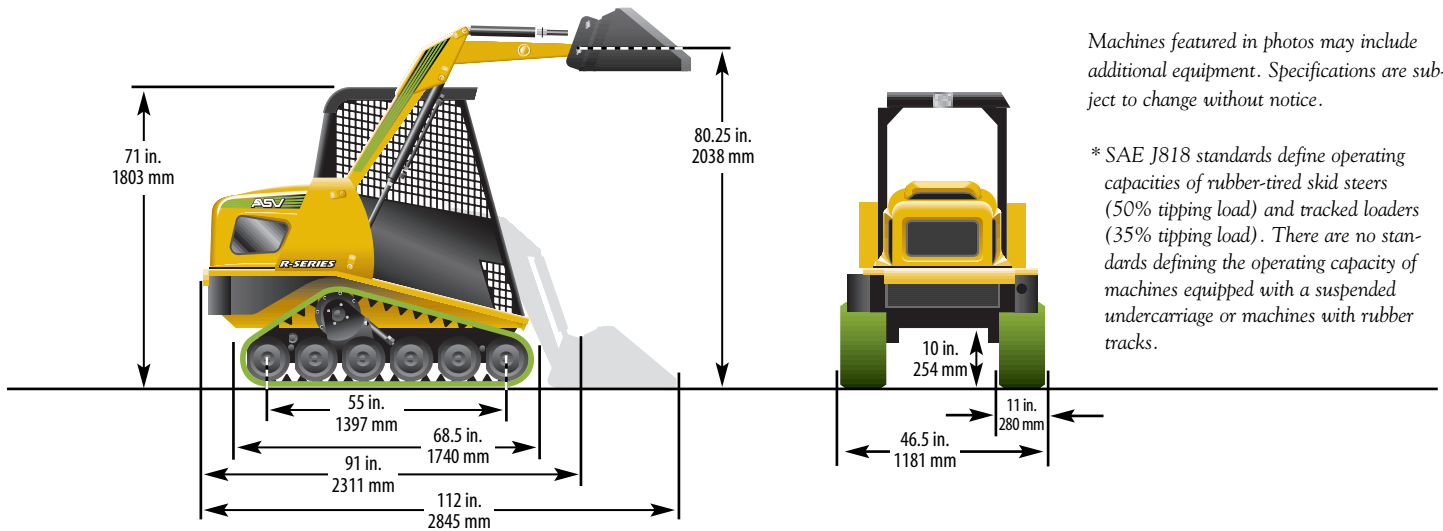

Machines featured in photos may include additional equipment. Specifications are subject to change without notice.

* SAE J818 standards define operating capacities of rubber-tired skid steers (50% tipping load) and tracked loaders (35% tipping load). There are no standards defining the operating capacity of machines equipped with a suspended undercarriage or machines with rubber tracks.

Machine Weight

Operating weight:	3,305 lb. / 1500 kg.
Shipping weight, w/out bucket:	2,935 lb. / 1331 kg.
Ground pressure:	
@ shipping weight	2.5 psi / 17.5 kPa
@ operating weight	2.9 psi / 19.3 kPa

Track Specifications

Track width:	11 in. / 280 mm
Track length, on ground:	55 in. / 1397 mm
Ground contact area:	1,183 in. ² / .76 m ²

Auxiliary Hydraulic Pump

Flow, maximum:	10 gpm / 37.9 lpm
Pressure:	3,000 psi / 20 670 kPa

Engine

Type (Diesel) :	Perkins 403C-15
Displacement:	92 in. ³ / 1.5 L
Gross power @ 2800 rpm:	31.5 hp / 23.5 kW
Torque, peak:	64.39 ft-lb / 87 Nm

Operating Specifications

Tipping load:	1,600 lb. / 726 kg
Operating capacity 50% tip load*:	800 lb. / 363 kg
Operating capacity 35% tip load*:	560 lb. / 254 kg
Travel speed, max.:	6 mph / 9.4 kmh

Service Refill Capacities

Fuel tank:	10 gal. / 37.9 L
Hydraulic tank:	8 gal. / 30.3 L
Engine coolant:	1.5 gal. / 5.6 L
Engine oil, inc. filter:	4 qt. / 3.8 L

Standard Features

Air cleaner, dual-stage
 Alternator, 55-amp
 Auxiliary hydraulics
 Battery, 750 CCA
 Brake, parking
 Bucket controls, pilot hyd.
 Drive control, pilot hyd.
 Electrical system, 12-volt
 Engine, diesel,
 Perkins 403C-15
 Final drive, direct hydrostatic
 Fuse box, automotive type
 Gauges:
 - fuel level
 - hour meter
 - slope indicator
 Heater, engine block
 Hitch receiver
 Ignition switch, key
 Interior dome light
 Lap bar/arm rest
 Loader arms

Operator presence switch
 Quick-attach interface
 Quick-connect auxiliary hydraulic fittings
 ROPS/FOPS canopy
 Rubber track undercarriage
 Screened engine compartment
 Throttle, hand-operated
 Tie-down loops, front/rear
 Transmission, hydrostatic
 Seat belt, two-inch wide
 Working lights, halogen:
 - two front, fixed
 - one rear, adjustable
 Warning lights:
 - coolant temp
 - engine oil pressure
 - hot hydraulic oil
 - low battery
 Wiring - pre-installed for all accessory switches

Options

Back-up alarm
 Beacon, rotating
 Cab enclosures
 Front door
 Heater, cab

Horn
 Lift points, bolt-on
 Seat belt, three-inch wide
 Sound insulation
 Wiper, front door
 Windows, glass