

HiReach™ H90F

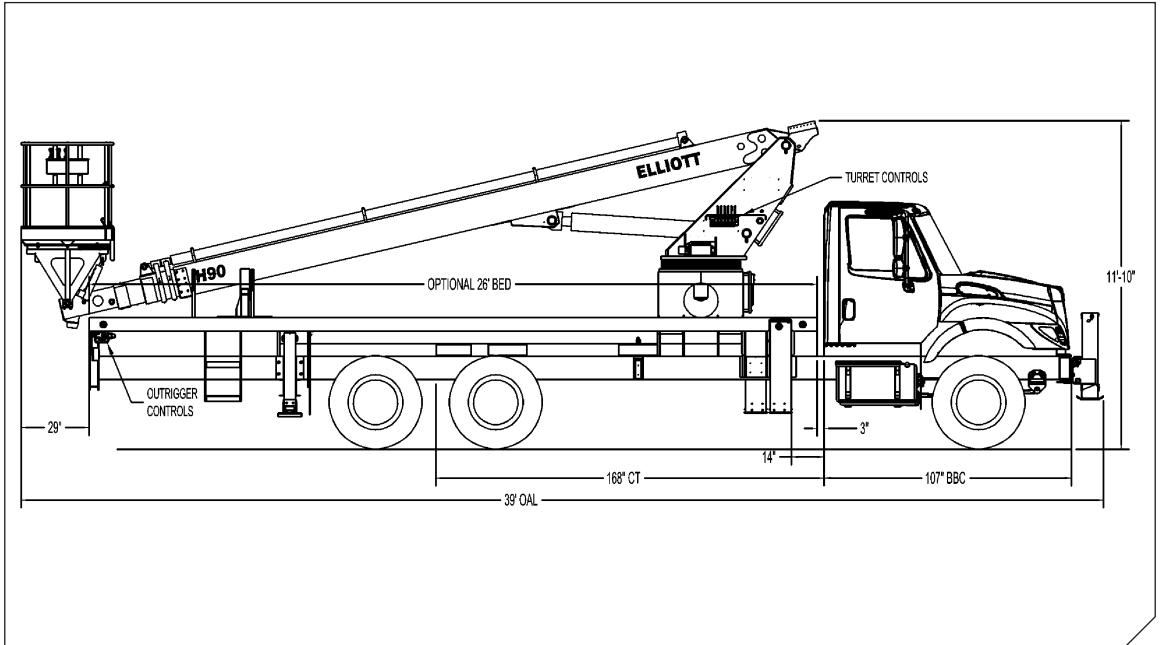

General Unit Description

HiReach – The machine that launched an industry, the wide-ranging Elliott HiReach telescoping aerial workplatforms and cranes allow you to do more with just a single machine. From material handling and digging to basic crane and boom, the HiReach does the work of a fleet of trucks. Available with heights ranging from 35 feet to 158 feet, the HiReach comes fully equipped with standard features that are sold as options by our competition. Only Elliott features full hydraulic extension with no cables and chains. Our extension cylinder arrangement gives you the smoothest, most precise ride in the industry. What's more, all of Elliott's products can be customized to create tailor-made machines that include special platform features, pressure washers, body and tool box packages and more.

Basic unit includes base assembly supporting front mounted rotating turret, hydraulically powered continuous rotation mechanism, oil reservoir mounted to truck frame, oil, and manual hydraulic controls mounted to turret. Electronic proportional three stick remote controls on platform. Base mounted "MH" type hydraulically powered individually controlled main outriggers. Underslung "A" type outriggers for rear stabilization. Front bumper stabilizer. High strength steel four section hydraulically telescoping boom with one double acting 6-1/2" lift cylinder. Two exposed cable carriers to boom tip. Hydraulically self-leveling 40" x 60" top mounted work platform with remote leveling from platform. Power take off and pump drive, pressure gauge, pump and holding valves on all cylinders. Remote start/stop at upper and lower controls, 12-volt emergency pump with switch at upper and lower controls, PTO hour meter, backup alarm, fire extinguisher, and two body harnesses and lanyards. Paint Hi-Reach white, outriggers red and bed and boxes black. Installed on chassis, tested and ready to operate. Unit certified to ANSIA92.2 for Vehicle-Mounted Elevating and Rotating Aerial Devices. Platform capacity 600 Lbs.

Technical Specifications

Minimum Platform Height: 90' ground to platform floor.

Working Range: 95' max. height and 61' max. side reach.

Work Platform: Inverted "A" sub-frame with steel frame expanded metal floor and light wall tubular rails. Detachable platform support fitted to end of telescoping section with 1-1/2" diameter platform pivot shaft. Equipped with safety chain on opening and two safety lanyard attachment loops. Two safety harnesses with 72" lanyards provided. Standard rating 600 lbs.

Platform Leveling System: Hydraulic "closed" system consisting of twin platform cylinders interacting with a boom-actuated master cylinder mounted in boom support turret. System provided with factory-set relief valves to compensate for oil expansion or overload during platform leveling operation. Remote leveling controls provided in platform and at ground controls to give precise releveling capability.

Platform Controls: Three individual proportional electronic controllers meter pilot-operated, pressure-compensated modulating valves. Remote controls for boom operations from platform operate from a removable remote control box. Hi/Lo range, start/stop and engine speed toggle controls are also located at platform. Electric remote control cable extends through the electrical slip ring to cable carrier on side of boom to extending boom sections.

Lower Controls: Mounted on curbside of turret.

Outrigger Controls: Parallel open-center stack valve for lever-operated control of right and left outriggers. The main and secondary outrigger valves are mounted at the rear, under each corner of the bed with roadside valve controlling roadside outriggers and curbside valve controlling curbside outriggers. Front bumper jack controlled with single valve at front bumper.

Outriggers: "MH" out-and-down main outriggers with 18 ft. spread. Additional stabilization provided by underlung rear outriggers and one tilting front bumper jack.

Frame: One piece, all welded, box-type fabrication with integral outrigger mounts. Bolt-on torque frame distributes load to rear outriggers.

Turret: Reverse offset turret is one-piece weldment. Turret rotates on large diameter ball bearing.

Rotation: Continuous turret rotation with no stops. Hydraulic motor drives turret through self-locking gear box.

Boom: High Strength steel rectangular tube sections with 1/4" wall thickness. Assembly includes heavy-duty cylinder fittings, pivot pins, and replaceable wear pads.

Boom Extension: 3" "Piggyback" internal cylinders with 2" rods extending the two outer boom sections. Largest telescopic section extends with an overslung 3-1/2" external cylinder with 2" rod.

Lift: One double-acting 6-1/2" full displacement, long stroke cylinders provide smooth and stable boom elevation. Holding valve prevent boom from falling in event of hose failure.

Cylinders: All cylinders use microhoned cylinder tubing, chrome shafts, top grade packing and protective rod wipers. Cylinder-mounted holding valves provided on all load-holding cylinders.

Hoses: All high pressure hose is wire braid reinforced with a minimum safety factor of 4 to 1.

Oil Tank Capacity: 70 gallon mounted to truck frame on roadside.

Hydraulic System: Operating pressure approximately 3,000 PSI. System is parallel open center type and is equipped with liquid-filled pressure gauge. Oil is supplied to upper cylinders through hydraulic union in center of turret to cable carrier along side of the boom.

Pump: Gear type, direct mount to truck PTO. 20 GPM @ 3,000 PSI on high engine speed.

PTO: Heavy-duty, high-speed. Cable engaged from cab.

Cab Equipment: PTO cable with indicator lights installed in truck cab. Engine speed control and start/kill installed with control switches in platform remote control box and also located at lower controls. U/L approved 5:BC dry chemical fire extinguisher installed in truck cab.

Operators Manual & Video: Two copies of operation, maintenance, safety and parts manual provided with each unit. Operational and safety video provided at delivery.

Installation: Unit installed on customer's truck, painted, system and tank filled with oil, tested, inspected, certified and ready to operate.

Standard Paint: Paint Hi-Reach white, outriggers red, and bed and boxes black. Top of bed painted with black nonskid surface.

Bumper: Bureau of Motor Carrier Safety rear bumper.

Weight: Approximately 21,000 lbs. with 26' steel-floor bed less truck.

Truck Chassis Required: Approx. 168" C.T. RBM 2,000,000 in-lb. per rail, 14,000 lb. front axle and 48,000 lb. GVWR required. Trucks must have extended rear frame, increased cooling, heavy-duty front and rear springs, 12V electrical system with high capacity alternator, cab clearance stop/tail/backup lights, and I.D. lamps. Additional equipment to consider: front tow hook, pintle hook, mud and snow tires for off highway use. Recommended GVWR is minimum for HI-REACH with flatbed only. Contact factory when additional equipment is to be added.

Options

Bed: Length 26' (other lengths available) Width 98" with 3/16" steel tread plate floor, 6" rub rail and heavy duty cross members. Stake pockets on both sides of bed. Spray suppressant splash guard installed. Chassis stop/turn/back-up lights remounted as necessary. Rear clearance and side market lights with reflectors on bed.

Platform Rotation: Manual, electric or hydraulic platform rotation available.

Heavy-Duty Hydraulic Winch: Mounted at the base of the boom for a long fleet angle and flat level spooling of cable. Option includes separate PTO, pump and valve for winch. Heavy-duty two-speed winch supplied with 250 ft. of 1/2" diameter 6x37 EIPS IWRC wire rope and swivel hook. Anti-2-block switch, 2-part hook, horn, load indicator system with digital display and certification to ANSI B 30.5 mobile cranes provided.

Platform Jib
Hydraulic, Air & 110V Lines to Platform

Welder Generators

Wood-Floor Bed

Line Bodies

Tool Storage

Full Cab Guard

Miscellaneous Options...Contact factory for details

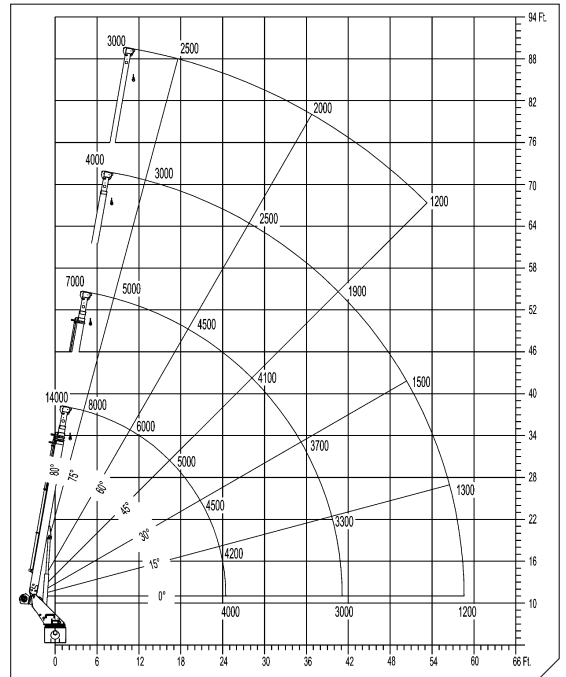

THIS AERIAL DEVICE IS NON-INSULATING. IT PROVIDES NO ELECTRICAL PROTECTION. CONTACT WITH OR INADEQUATE CLEARANCE TO AN ENERGIZED LINE OR APPARATUS IS AN ELECTROCUTION HAZARD.



4427 South 76th Circle

Omaha, NE 68127

Phone: 402-592-4500

Fax: 402-592-4553

Email: info@elliottequip.com

www.elliottequip.com