

STELLAR AGGRESSOR™

15000 OTR



Power, Precision, Durability. That's what you get with the Stellar 15000 OTR series, designed from the ground up to work in the OTR tire service industry. A durable 320° turntable rotation system driven by a worm gear / pinion system ensures rock solid rotation performance. This crane features a lifting capacity of 15,000 lbs. at 10' and 9,000 lbs. at 16'6" of total reach, without the tire manipulator.

Stellar's modified A-frame outrigger design is an industry first. Only the Stellar 15000 offers the stability and durability of A-frame outriggers with the diversity of out and down style outriggers. By modifying the A-frame geometry and using dual cylinders we are able to allow A-frame stability at differing outrigger widths.



The TM6120 offers over 143 ° of articulation and 360° continuous rotation. Shown below is the TM6120 at full upward and downward articulation. The TM6120's flexibility of movement allows the operator to maneuver OTR tires in the safest and quickest manner possible. With a clamping width of 120", the TM6120 can easily handle tire and tire rim combinations up to 6,800 lbs. The unique parrallelogram design of the TM6120 not only gives it considerable clamping width, but it also has the ability to clamp tires as small as 48" without a pad extension kit.

15000 OTR Series

STELLAR AGGRESSOR™ 15000 OTR

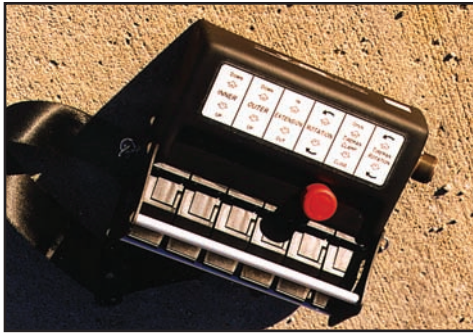

The Stellar infinitely proportional remote control system offers precise, smooth, multi-function crane operation. The radio remote control features paddle handles which allow the crane operator to engage multiple crane functions with the same precision as manual controls. This system comes standard on the 15000 crane.

(A tethered radio remote control system is optional.)

Stellar's model SHD-245 air compressor is designed to meet the rigors of the heavy duty OTR tire service industry. The industrial 4-cylinder, 2-stage compressor is powered by a hydraulic motor and outputs 110 CFM @ 175 PSI. All air compressors are top mounted to stay clean and cool. This also enhances serviceability and easy access



The chart below shows the lifting capacities and reach for the 15000 crane **without** the TM6120.

The TM6120 has a lifting capacity of 6,000 lbs.

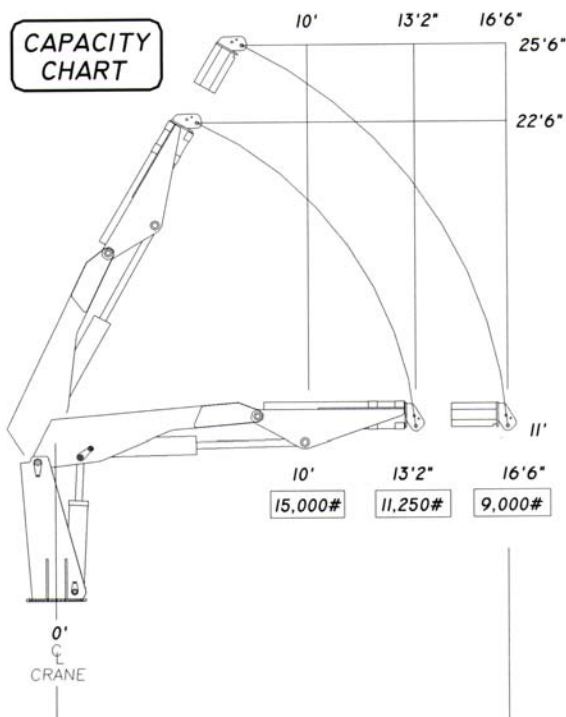

The 156-17 heavy duty OTR body shown below is designed to meet your heavy duty OTR needs. Features include underbody tool compartments with slide top doors, front mounted vertical cabinets for abundant storage of tools, tubes, workwear and a 5-gallon insulated water cooler. All tool boxes are equipped with stainless steel automotive style slam latches. D-ring tie downs, recessed skirt-mounted halogen floodlights, DuPont Imron 5000 paint, and complete body undercoating. A heavy duty frame mounted push bumper is located at the rear of the body.



280 West Third Street
 Garner, Iowa 50438
 1-800-321-3741
 Fax: 641-923-2812
 E-mail: sales@tiretruck.com
 www.tiretruck.com

Designed & Manufactured in the U.S.A.

*Specifications may change without notification.
 Copyright © 2003 Stellar Industries, Inc.