

Stellar Slider65



The Stellar Slider65 hooklift is a body handling system mounted on a truck chassis that is capable of loading, unloading and dumping various bodies with lengths ranging from 16' to 22' (4877mm to 6706mm) with the use of a hexagonal sliding jib. Now with an adjustable hook height, the Slider65 will handle 54" (1372mm) or 61.75" (1568mm) hook height bodies and will accommodate capacities up to 65,000 pounds. The maximum dump angle is 50° on a 41-inch (1,041mm) high truck frame.



The Stellar Slider series hooklift is known for its versatile design and ease of operation. All models of the Stellar Slider feature permanently lubricated and greaseable bushings used throughout, the Stellar patented dump/load interlock system, and an efficient low flow/high pressure hydraulic system.

Safety features include rugged rear body tie-downs to insure body stability when in transit, in-cab controls and various safety latches. Only Stellar's Slider hooklifts provide a full-length dump frame with front saddles to support the body during the dump mode. The Stellar Slider65 also features hexagonal booms to reduce flexing, add structural integrity and ease the replacement of wear pads.



*Designed & Manufactured
in the USA*

STELLAR
INDUSTRIES INC.

65,000 Pound Capacity

Stellar Slider65

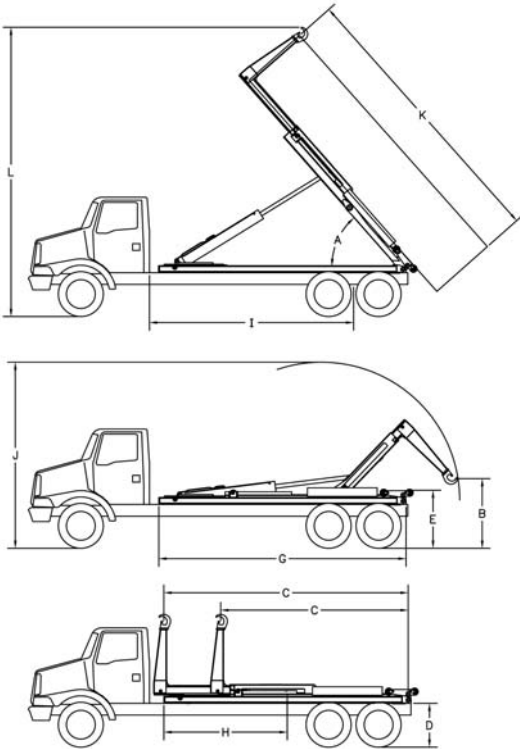

- Will accommodate bodies from 16-feet up to 22-feet (4877mm to 6706mm) long and still attain the maximum dump angle on a 41-inch (1041mm) high frame truck. Longer bodies may be accommodated with reduced dumping capabilities.
- Transmission-mounted PTO and hydraulic pump required to power the Hooklift loader.
- Standard in-cab manual controls which allow for precise metering of the manual hydraulic valve. Solenoid-activated hydraulic control valve with electric remote control pendant is optional.
- Twenty-five (25) gallon (95L) frame-mounted oil tank.
- Operating pressure is 4,500psi. (31Mpa)
- Hydraulic flow required is 20-gallons (76L) per minute.
- Patented dump/load interface as featured on most Stellar Shuttle Hooklift loaders.
- Hydraulic locks to prevent cylinder collapse in case of hose failure.
- Slide through rear body tie-down latches.
- Hydraulic lock-out valve to prevent front jib movement when the dump frame is raised.
- Permanently lubricated and greaseable bushings used throughout.
- Stainless steel pins used throughout.
- All weldments painted with DuPont® Imron® 5000.

Lifting Capacity	52,000lbs. (23,587kg)	54" Hook Height	65,000lbs. (29,484kg)	61.75" Hook Height	65,000lbs. (29,484kg)
Dumping Capacity	65,000lbs. (29,484kg)				
A Dump Angle	50°				50°
B Lowest Hook Height	44.51" (1,131mm)				38" (967mm)
C Effective Length	193" to 224" (4,902mm to 5,690mm)				193" to 224" (4902mm to 5,690mm)
D Truck Frame Height	41" (1,041mm)				41" (1041mm)
E Hooklift Height	53.44" (1,357mm)				53.44" (1,357mm)
G Hooklift Length	227" (5,766mm)				227" (5766mm)
H Hooklift Center of Gravity	103" (2,616mm)				103" (2616mm)
I Chassis Cab to Trunion	180" (4,572mm) optimum***				180" (4,572mm) optimum***
	170" (4,318mm) minimum***				170" (4,318mm) minimum***
	190" (4,826mm) optimum with tarping system***				190" (4,826mm) optimum with tarping system***
J Max. Height When Loading	175" (4,445mm)				179" (4547mm)
K Longest Body to Dump	24' (7,315mm)				24' (7315mm)
L Max. Height When Dumping	259" (6,579mm)				264" (6706mm)
Maximum Operating Pressure	4,500psi (31Mpa)				4,500psi (31Mpa)
Shipping Weight (pounds)	6,600lbs. (2,994kg)				6,600lbs. (2,994kg)
Shipping Dimensions (LxHxW)	234" x 86" x 53" (5944 x 2184 x 1346 mm)				234" x 86" x 53" (5944 x 2184 x 1346 mm)
Min. Truck GVWR (pounds)	54,000lbs. (2,4494kg)				54,000lbs. (2,4494kg)
Load Angle w/ Shortest Body Length	40°				37°
Recommended Container Lengths*	16' to 22' (4877mm to 6706mm)				16' to 22' (4877mm to 6706mm)
Recommended Flatbed Lengths**	16' to 24' (4877mm to 7315mm)				16' to 24' (4877mm to 7315mm)

*(Assumes 3ft. overhang from center of rear roller pin)
(Bumper typically 12" from center of roller pin)

** (Assumes 5ft. overhang from center of rear roller pin)
(May require bumper and latch options)

*** (Weight distribution should always be done)

Your local distributor:



Our People. Our Products.

Copyright © 2007 Stellar Industries, Inc.

190 State Street
Garner, IA 50438
Telephone: 800-321-3741
Fax: 641-923-2812
www.stellarindustries.com
sales@stellarindustries.com

*Specifications may change without notification.