

Stellar Cranes



The Stellar EC2K, or Econo-Crane 2000 is an economical service crane with a 6500 ft/lb. capacity. This mast crane is designed to be mounted on bodies ranging from foreign and domestic pickup boxes, to large garbage packers, and any application in between. The EC2K has four lifting positions, a hand-operated brake, and one folded position for space saving storage.



The EC2K-P offers a 12-volt power rotation for added ease of operation. The EC2K line of cranes has a 2000 lb. capacity (two-part line), with the option of a single-part line. It can be extended from a 4-foot stowed position to a maximum 7-foot reach. The rugged, dependable, 12-volt electric winch has a twelve-foot detachable remote control pendant to allow operation of the crane safely from the load area. With a line speed of 20-ft./min. one person can safely load and unload payloads up to 2000 lbs. quickly. For ease of operation, and economical investment, this crane is built to the highest standards demanded of all Stellar products.

Designed & Manufactured
in the USA **STELLAR**
INDUSTRIES INC.

EC2K & ECEK-P Crane

Stellar Cranes

CAPACITY CHART

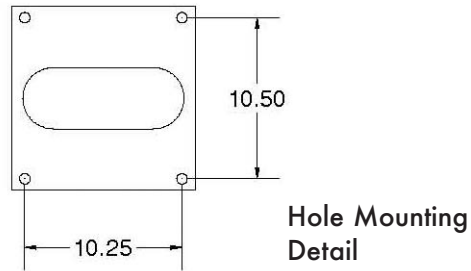
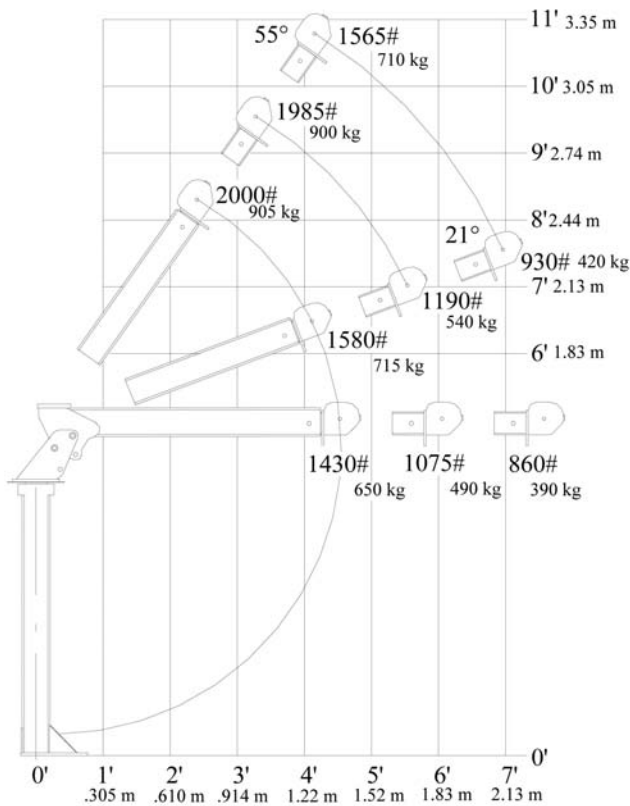

Crane Specifications

- Crane rating6,500 ft/lbs.
- Standard boom length.....4' from CL of crane
- Boom extension1st stage: Manual 18"
2nd stage: Manual 18"
- Cable40 ft. of 3/16" dia. GAC
- Max. horizontal reach7' from CL of crane
- Max. vertical lift10' 9"
- Speed ft/min.Unloaded (0 lbs.): 19.5
Loaded (1000 lbs.): 14.7
- Current draw 12-volt (amps)Unloaded (0 lbs.): 30
Loaded (1000 lbs.): 80
- Boom elevation0° to +21° to +56°
- Rotation340° manual
320° power rotation
- Lifting capacities1,580 lbs. at 4'
1,190 lbs. at 5' 6"
930 lbs. at 7'
- Stowed height59.50"
- Mounting space req.12" x 12"
- Approx. shipping weight275 lbs.
230 lbs. (short mast)
300 lbs. (power rotation)
- Also available in short mast versions



Tethered remote is removable for easy storage.



190 State Street
P.O. Box 169
Garner, IA 50438
Telephone: 800-321-3741
Fax: 641-923-2812
Internet: www.mechanictruck.com
email: sales@mechanictruck.com

Quality You Ask For By Name.
Designed & Manufactured in the U.S.A.

*Specifications may change without notification.
Copyright © 2004 Stellar Industries, Inc.