

STELLAR HOOKLIFT



The Stellar Flex36 series is a technologically advanced hooklift that has been designed to replace nine current Stellar hooklift models with four. These four Flex36 Series hooklifts, accommodating cab to axle measurements of 60, 84, 108 and 120 can be pressure adjusted* to accommodate lifting capacities ranging from 9,000 pounds up to 16,000 pounds depending on the GVWR of the chassis. No other hooklift manufacturer currently offers this kind of flexibility. The Flex36 can handle dump containers ranging from 8' to 15' and flatbeds ranging from 10' to 16' and has a lifting capacity of up to 16,000 pounds. It has a maximum dump angle of 50° to 54°, depending on the length of body.



The Flex36 Series was engineered using the most advanced levels of design tools, including finite element analysis and strain gauge validation testing as well as extensive data collected from our customers. This advanced design process has allowed Stellar to build a hooklift that will grow with the customer, effectively saving time and money by not having to purchase new equipment to accommodate this growth. It has also streamlined the manufacturing process, which has reduced the weight of the hooklift and has allowed for a greater net payload, making it even more competitive in the marketplace and more profitable for the end user.



The Stellar Flex36 also incorporates the same standard features found on all models of Stellar hooklifts, including the resettable dump/tilt tabs, DX pre-lubricated bushings, the Stellar patented dump/load interlock system, and an efficient low flow/high pressure hydraulic system. Rugged rear body tie-downs insure body stability when in transit. Only Stellar hooklifts provide a full length dump frame with front saddles to support the body during the dump mode.

At Stellar Industries, we work hard to give you a hooklift system that offers versatility while cutting costs and maintenance. We are committed to giving you the competitive edge.

*Designed & Manufactured
in the USA* **STELLAR**
INDUSTRIES INC.

* Please consult Stellar Flex36 owner's manual for proper adjustment procedures.

FLEX36 Series

STELLAR FLEX36 HOOKLIFT

	<u>60-8</u>	<u>84-10</u>	<u>108-12</u>	<u>120-14</u>
Lifting/Dumping Capacity (pounds)	Up to 9,000	Up to 16,000	Up to 16,000	Up to 16,000
A Dump Angle	54°	53°	54°	50°
B Lowest Hook Height	23.5"	25"	27"	28"
C Effective Length	91"	115"	142"	151"
D Truck Frame Height	34"	36"	36"	36"
E Loader Height	39.5"	41.5"	41.5"	41.5"
G Loader Length	99.25"	126"	154"	161"
H Loader Center of Gravity	43"	58"	68"	70"
I Chassis Cab to Axle	60"	84" to 96"	108" to 120"	120" to 130"
J Max. Height When Loading	104"	118"	135"	136"
K Longest Body to Dump	120"	144"	180"	192"
L Max. Height When Dumping	141"	162"	185"	187"
Shipping Weight (pounds)	1,275	1,360	1,615	1,650
Hook Height (from bottom of hook bar)	35.63"	35.63"	35.63"	35.63"
Shipping Dimensions (LxHxW)	100" x 49" x 47"	126" x 49" x 47"	154" x 49" x 47"	161" x 49" x 47"
Min. Truck GVWR (pounds)	10,500 to 15,000	10,500 to 26,000	10,500 to 26,000	10,500 to 26,000
Load Angle w/ Shortest Body Length	38.5°	35°	36°	32°
Recommended Body Lengths*	8' to 9'	10' to 12'	12' to 14'	13' to 15'
Recommended Body Lengths**	To 10'	To 13'	To 15'	To 16'

*Recommended container/dump body length
 **Longest recommended flatbed length

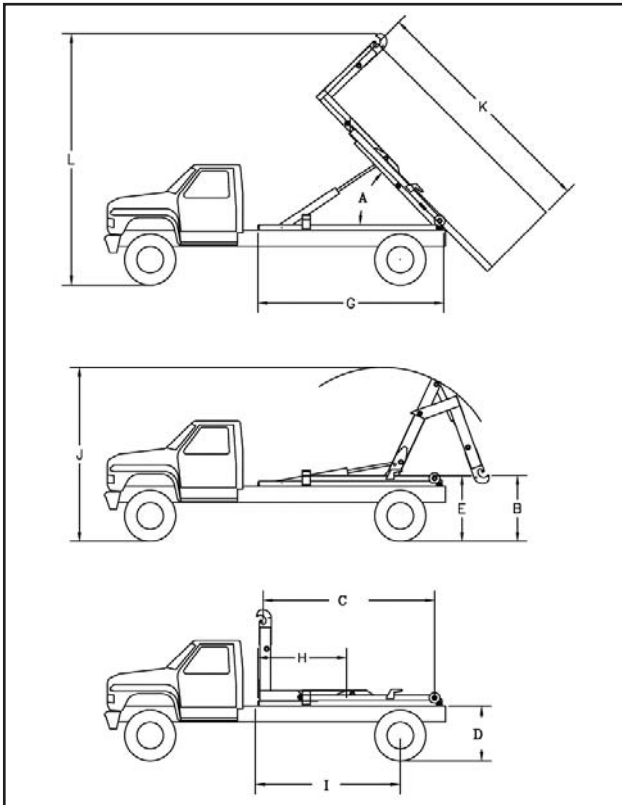

- Standard in-cab manual controls which allow for precise metering of the manual hydraulic valve. Solenoid-activated hydraulic control valve with electric remote control pendant is optional.
- Ten (10) gallon capacity frame-mounted oil reservoir.
- Hydraulic flow shall not exceed 16-gallons per minute.
- Patented dump/load interface on double pivot models.
- Hydraulic locks to prevent cylinder movement in case of pressure loss.
- Mechanical rear body tie-down latches.
- Resettable dump/tilt tabs.
- Hydraulic rotary valve to prevent front tilt movement when the dump frame is raised.
- DX pre-lubricated bushings used at pivot points.
- Grease zerks at all pin points to allow purging of contaminants.
- Greaseable load rollers.

Your local dealer:



Quality You Ask For By Name.

190 State Street
 Garner, IA 50438
 Telephone: 800-321-3741
 Fax: 641-923-2812
 www.stellarindustries.com

© 2005 Stellar Industries, Inc.

*Specifications may change without notification.

9/05m