

Distribution Dry Type Transformers

600 Volts Class — Single and Three Phase

Selection

600 Volts Class

Single Phase 0.25–167 KVA

Three Phase 3–1000 KVA

Features

- Standard units are UL listed and are designed in accordance with ANSI, NEMA (ST20) and IEEE standards

Encapsulated

- UL listed designs (UL 506)
- Totally enclosed, non-ventilated, heavy gauge steel enclosure
- Core and coil completely embedded within a resin compound for quiet, low temperature operation
- Encapsulation seals out moisture and air
- UL listed indoor/outdoor enclosure features integral wall mounting brackets
- Rugged design resists weather, dust, and corrosion
- Efficient, compact, lightweight, easy to install
- Flexible wiring leads that terminate within the bottom wiring compartment
- Large wiring compartment on the bottom with convenient knockouts
- High quality non-aging electrical grade core steel
- Precision wound coils

Ventilated

- UL listed designs (UL 1561)
- Designed for indoor NEMA 2 installations. NEMA 3R enclosures suitable for outdoor locations available as an option
- Core and coils are designed with UL listed high-temperature materials rated for 220°C; standard units feature 150°C winding temperature rise
- Optional low temperature rise of 115°C or 80°C winding temperature rise for increased efficiency and additional overload capability
- Rugged sheet steel enclosure per UL1561, UL506 standards with removable panels for access to the internal wiring area
- Neoprene noise dampening pads isolate the core and coil from the enclosure
- Optional drip shields/weathershield and wall brackets available
- High quality, non-aging electrical grade core steel
- Precision wound coils



Encapsulated Transformer



Ventilated Transformer

Single Phase Transformer Ampere Ratings

Single Phase Full Load Amperes (FLC)						
KVA	120V	208V	240V	277V	480V	600V
.25	2.0	1.2	1.0	0.9	0.5	0.4
.50	4.2	2.4	2.1	1.8	1.0	0.8
.75	6.3	3.6	3.1	2.7	1.6	1.3
1	8.3	4.8	4.2	3.6	2.1	1.7
1.5	12.5	7.2	6.2	5.4	3.1	2.5
2	16.7	9.6	8.3	7.2	4.2	3.3
3	25	14.4	12.5	10.8	6.2	5
5	41	24	20.8	18.0	10.4	8.3
7.5	62	36	31	27	15.6	12.5
10	83	48	41	36	20.8	16.7
15	125	72	62	54	31	25
25	206	120	104	90	52	41
37.5	312	180	156	135	76	62
50	416	240	208	180	104	83
75	625	340	312	270	156	125
100	833	480	416	361	208	166
167	1391	803	695	603	347	278

Three Phase Transformer Ampere Ratings

Three Phase Full Load Amperes (FLC)				
KVA	208V	240V	480V	600V
3	8.3	7.2	3.6	2.9
6	16.6	14.4	7.2	5.8
9	25	21.6	10.8	8.6
15	41.7	36.1	18.0	14.4
30	83.4	72.3	36.1	28.9
45	124	108	54.2	43.4
75	208	180	90	72
112.5	312	270	135	108
150	416	360	180	144
225	624	541	270	216
300	832	721	360	288
500	1387	1202	601	481
750	2084	1806	903	723
1000	2779	2408	1204	963

Insulation Class and Temperature Rise

KVA		Insulation		
1-Phase	3-Phase	NEMA Class [®]	Temperature Class	Temperature Rise
0.25–25 ^①	3–15	F	180° C	115° C
15–167	15–1000	H	220° C	150° C

Sound Level in Decibels[®] — 600V Class

KVA	NEMA Average dB	KVA	NEMA Average dB
0–9	40	301–500	60
10–50	45	501–700	62
51–150	50	701–1000	64
151–300	55		

① 25KVA 277 -120/240 is 115°C rise. 25KVA 480 x 240 -120/240 is 150°C rise.

② Average sound level applies to 150°C rise K-1 transformers. Average dB levels for low temperature and other K-Factor ratings available upon request.

③ NEMA Class for 80°C rise = B, 115°C rise = F, 150°C = H. Insulation class per UL 1446 180° = (H), 220° = (R)

Transformers

Dry Type Distribution 600 Volt Class

General

Siemens dry type distribution transformers are rated 600 volt class and are available in a wide variety of ratings to provide versatile electrical distribution for general purpose, lighting and power loads in commercial and industrial applications.

Ratings are available from 0.25 through 167 kVA single phase, and 3 through 1000 kVA 3-phase. A variety of primary and secondary voltage ratings are available to match the load requirements to the distribution system. All units meet applicable ANSI and NEMA standards. Standard designs are UL Listed.

Dry type transformers are air cooled by natural convection. They require no special vaults for installation, and can be installed in locations convenient to the load being served.

Encapsulated designs are provided for ratings from 0.25 kVA through 15 kVA, 1-phase, and from 3 kVA through 15 kVA 3-phase. These designs feature indoor/outdoor enclosures with integral wall mounting brackets, and 115°C rise, 180°C insulation system.



Encapsulated Transformer

Ventilated designs are provided for ratings from 25 kVA through 167 kVA 1-phase, and from 15 kVA through 1000 kVA 3-phase. These feature indoor enclosures, 150°C rise, and 220°C insulation system.



Ventilated Transformer

A wide variety of designs and optional accessories are available including weather shields for outdoor NEMA 3R protection.

K-Factor Rated for Non-Linear Loads

Siemens offers transformer designs which meet K-Factor ratings. K-Factor is a ratio between the additional losses due to harmonics and the eddy losses at 60Hz. It is used to specify transformers for non-linear loads. Note that K-Factor transformers do not eliminate harmonic distortion; they withstand the non-linear load condition without overheating.

K-Factor Features

- Designed to ANSI and NEMA Standards
- UL K-Factor Listed per UL 1561
- K-Factor Rating Designed to IEEE c57.110
- Aluminum Wound Coils
- Core, Conductors designed for Harmonics and Eddy Currents 150°C Rise, 220°C Insulation
- Electrostatic Shield to Attenuate Line Transients
- 200% Neutral Bar (2X Phase current)
- NEMA 1 Enclosure

Options

- Special K-Factor ratings
- Special voltage ratings
- NEMA 3R Enclosure
- 80° or 115°C temperature rise
- Low noise designs

- Copper windings
- Drip shields
- Wall mounting brackets (15–50 kVA)

Encapsulated Features

- UL Listed Designs
- Totally Enclosed, Non-Ventilated
- Heavy Gauge Steel Enclosure
- Core and Coil Completely Embedded Within a Resin Compound — quiet, low temperature operation
- Encapsulation — seals out moisture and air
- UL Listed Indoor/Outdoor Enclosure — features integral wall mounting brackets
- Rugged Design Resists Weather, Dust, and Corrosion
- Efficient, Compact, Lightweight — easy to install
- Flexible Wiring Leads Terminate Within Bottom Wiring Compartment
- Large Wiring Compartment on Bottom with Convenient Knockouts
- High Quality Non-Aging Electrical Grade Core Steel
- Precision Wound Coils

Options

- Copper windings
- Electrostatic shield (3 kVA and larger)

Ventilated Features

- UL Listed Designs
- Designed for Indoor Installation
- Core and Coils are Designed with UL Listed High-Temperature Materials — rated for 220°C; standard units feature 150°C winding temperature rise
- Rugged Sheet Steel Enclosure per ULI561, UL506 standards with Removable Panels for Access to Internal Wiring Area
- Neoprene Noise Dampening Pads Isolate the Core and Coil from the Enclosure
- High Quality, Non-Aging Electrical Grade Core Steel
- Precision Wound Coils

Options

- Low temperature rise of 115°C or 80°C winding temperature rise for increased efficiency and additional overload capability
- Outdoor enclosures
- Totally enclosed non-ventilated designs
- Copper windings
- Electrostatic shield
- Low noise designs
- K-factor rated designs
- Drip shields and wall brackets available

Transformers

Dry Type Distribution 600 Volt Class

Specifications

K-Factor Rated For Non-Linear Loads

Furnish and install K-Factor rated dry type transformers of the two winding type, self-cooled, with 60Hz ratings as indicated on the electrical plans. Unless specified otherwise, provide standard NEMA taps, standard impedance, and standard sound levels. Transformers shall be Siemens or approved equal.

Transformers shall be designed, manufactured, and tested in accordance with ANSI, NEMA and IEEE Standards and shall be UL Listed. The self-coded kVA rating shall be suitable for 30°C average, 40°C maximum ambient temperature.

Non-Linear rated transformers shall be suitable for nonsinusoidal loads and harmonic distortion as indicated in IEEE C57.110, and shall be designed with the following K-Factor rating (choose one):

- K4 for 50% Non-Linear load
- K13 for 100% Non-Linear load
- K20 for 150% Non-Linear load
- K30 for 200% Non-Linear load

Non-Linear rated transformers shall be UL Listed and shall bear the UL marking on the nameplate along with the specified K-Factor rating. Non-Linear rated transformers shall include the following design features:

- a) Core designed to withstand voltage distortion and high frequency harmonic currents. Magnetic flux density designed to reduce eddy currents and prevent saturation or overheating of the core.
- b) Primary and secondary coils designed to minimize stray losses, skin effect losses, and excessive heating from harmonic currents. Coils shall not exceed the specified

winding temperature rise, the corresponding hot spot temperature rating, or the 220°C insulation rating while carrying the specified Non-Linear load.

- c) Neutral bus sized for 200% of rated current to withstand circulating currents and triplen harmonics.
- d) An Electrostatic Shield between the primary and secondary winding and grounded to a common point within the transformer enclosure. When properly grounded, the shield shall provide noise isolation and attenuate common mode and transverse mode noise transients under normal loading conditions.
- e) The design and materials used shall enable the transformers to comply with NEMA TP1 efficiency standards.

Transformers rated 15 kVA and larger shall be a ventilated dry type with a UL Listed 220°C insulation system. Units shall be designed to operate with a rated maximum temperature rise of 150°C (Provide optional 115°C or 80°C rise when specified).

Construction shall consist of aluminum windings and arranged to brace coil layers and provide maximum ventilation. (Provide optional copper windings when specified). Cores shall be constructed of non-aging electrical grade steel with high magnetic permeability and low loss characteristics.

Core laminations shall be tightly assembled. The complete core and coil assembly shall be impregnated with non-hydroscopic thermo-setting varnish to provide a high dielectric, moisture-resistant, and flame retardant seal.

Core and coil assemblies shall be constructed to provide short circuit withstand capability as defined by ANSI and NEMA standards. The complete assembly shall be installed on vibration dampening pads to reduce noise and securely bolted to the enclosure base. A flexible grounding conductor shall be installed between the core and coil assembly and the transformer enclosure.

Enclosures shall be ventilated, heavy gauge steel construction finished with light gray paint. Front and rear covers shall be removable to provide access to the terminal compartment. Terminals shall be fully sized to carry the transformer full load current and shall be arranged to accept required UL-Listed cable connectors. Units installed outdoors shall have a UL-Listed type 3R outdoor enclosure, or shall be UL Listed with optional weathershields installed.

Standard voltage ratings shall be supplied with NEMA standard taps for the high voltage windings.

Unless specified otherwise, average sound levels (150°C rise) shall meet the following ANSI/ NEMA standards:

0 to 9 kVA	40 dB
10 to 50 kVA	45 dB
51 to 150 kVA	50 dB
151 to 300 kVA	55 dB
301 to 500 kVA	60 dB
501 to 700 kVA	62 dB
701 to 1000 kVA	64 dB

Each transformer shall have a securely attached nameplate providing complete electrical ratings, wiring diagram, tap connections, and catalog number, as applicable.

Distribution Dry Type Transformers

Catalog Number Coding System for Transformers

Selection

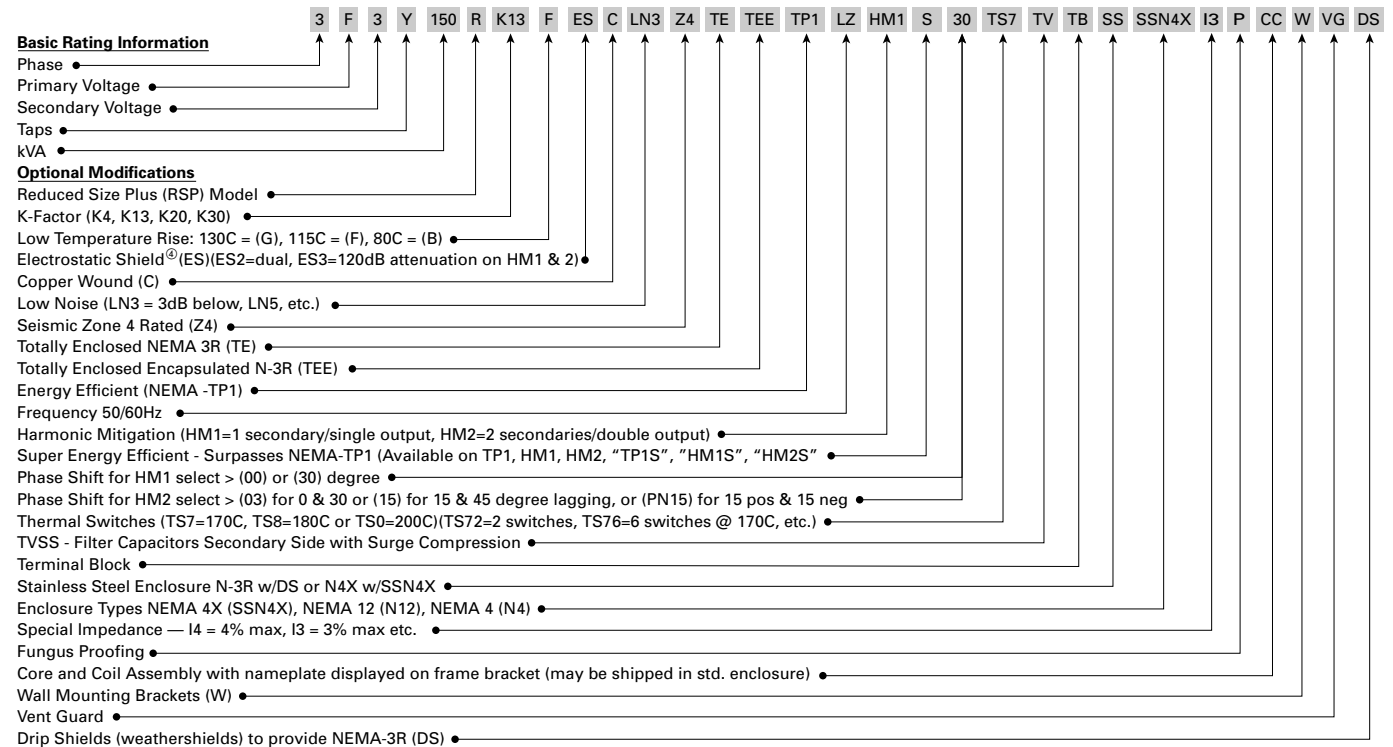

Note 1: If the catalog number will not completely describe the product, it will be identified as SPC-__KVA-XFMR.
 Note 2: "QST" suffix on catalog numbers defines units available in the Siemens warehouse distribution system.
 Note 3: Suffix K4TP1 or K13TP1 will indicate K-Factor rating and TP1 rating at K1 loading.

Phase		Primary		Secondary	
1-Phase	1	240X120	A	120/240	1
3-Phase	3	208	B	240 ^①	2
		240	C	208Y/120	3
		480X240	D	120/208 ^⑤	3
		277	E	480Y/277	5
		480	F	380Y/219	6
		600	G	230Y/133	7
				110/220	8
190/200/208/220x380	Export				
400/416/440	Range				
190/208/220/240x380	Export				
416/440/480	Range				

TAPS

Description ^②	Designation
4-3% (2 FCAN, 2 FCBN)	J
2-3.5% (1 FCAN, 1 FCBN)	K
3-5% (1 FCAN, 2 FCBN)	M
None	N
2-5% FCBN	R
2-5% (1 FCAN, 1 FCBN)	S
4-2.5% (2 FCAN, 2 FCBN)	T
2-2.5% FCBN	U
4-2.5% FCBN	X
6-2.5% (2 FCAN, 4 FCBN)	Y

KVA

KVA	Catalog Code	KVA	Catalog Code	KVA	Catalog Code	KVA	Catalog Code
0.25	205	5	005	30	030	150	150
0.50	505	6	006	37.5	037	167	167
0.75	705	7.5	007	45	045	225	225
1	001	9	009	50	050	300	300
1.5	105	10	010	75	075	500	500
2	002	15	015	100	100	750	750
3	003	25	025	112.5	112	1000	000

^① Available in 3-phase 3 to 15 KVA only.
^② Taps are determined by transformer design and are not selectable on standard catalog units.
^③ With continuous overloads these units will be operating at 150°C rise designs.
^④ "XES" Suffix coding for shielded isolation with filters & surge suppression.
^⑤ Applies to HMT designs.

OPTIONAL PRODUCT OFFERINGS

- For non-standard or non-cataloged voltages or non-cataloged primary taps refer to sales office.
- Non-standard application, 50/60 Hz, special impedance, voltage, etc. — consult sales office.
- Wall mounting brackets and weathershields — available at no charge on all indicated units when requested at time of initial project order. Contact sales office for feasibility of wall brackets on units with special temperature rise, low noise, or copper windings.
- Special temperature rise:
 - 115° C rise, can tolerate 15% continuous overload.^③ (Suffix Code F)
 - 80° C rise, can tolerate 30% continuous overload.^③ (Suffix Code B)
- Copper windings — Available on most designs. (Suffix Code C)
- Low Noise Suffix code LN3 (3dB below std.) available as indicated. For LN5, etc. contact sales office with required sound level.
- Totally Enclosed Non-Ventilated (TE) — see page 7-8.
- Auto transformers (A) — see page 7-11.
- Non-standard paint color — contact sales office.
- Electrostatic shield (full width copper foil) for added noise attenuation and reduction of high frequency disturbances. (Suffix Code ES)
- Energy Efficient (NEMA TP1), Meets TP1-1996 Efficiency.
- Harmonic mitigating transformers—see page 7-15.
- Transformer and panel combinations—see page 7-13.
- Reduced Size Plus models—see page 7-17.

7 TRANSFORMERS

Distribution Dry Type Transformers

Single Phase

Selection

KVA	Catalog Number	List Price \$	Taps ^①	Temperature Rise	Insulation	Mounting Type ^{②③}	Drip Shield Required ^③	Enclosure Style ^④	Optional Modifications
208 Volts Primary, 120/240 Volts Secondary									
1	1B1N001	377.00	N	115° C	180° C	Wall	No	Encapsulated	2
2	1B1N002	629.00	N	115° C	180° C	Wall	No	Encapsulated	2
3	1B1N003	770.00	N	115° C	180° C	Wall	No	Encapsulated	1b, 2, 3
5	1B1N005	967.00	N	115° C	180° C	Wall	No	Encapsulated	1b, 2, 3
7.5	1B1N007	1425.00	N	115° C	180° C	Wall	No	Encapsulated	1b, 2, 3
10	1B1N010	1614.00	N	115° C	180° C	Wall	No	Encapsulated	1b, 2, 3
15	1B1N015	1859.00	N	115° C	180° C	Wall	No	Encapsulated	1b, 2, 3
25	1B1Y025TP1	5509.00	N	150° C	220° C	Floor	Yes	Ventilated	1, 2, 3, 4, 5
37.5	1B1Y037TP1	6502.00	N	150° C	220° C	Floor	Yes	Ventilated	1, 2, 3, 4, 5
50	1B1Y050TP1	7597.00	N	150° C	220° C	Floor	Yes	Ventilated	1, 2, 3, 4, 5
75	1B1Y075TP1	18495.00	N	150° C	220° C	Floor	Yes	Ventilated	1, 2, 3, 5
100	1B1Y100TP1	20659.00	N	150° C	220° C	Floor	Yes	Ventilated	1, 2, 3, 5
167	1B1Y167TP1	51057.00	N	150° C	220° C	Floor	Yes	Ventilated	1, 2, 3, 5

240 × 480 Volts Primary, 120/240 Volts Secondary

.25	1D1N205	164.00	N	115° C	180° C	Wall	No	Encapsulated	None
.50	1D1N505	255.00	N	115° C	180° C	Wall	No	Encapsulated	None
.75	1D1N705	381.00	N	115° C	180° C	Wall	No	Encapsulated	None
1.0	1D1N001	380.00	N	115° C	180° C	Wall	No	Encapsulated	2, 1b
1.5	1D1N105	552.00	N	115° C	180° C	Wall	No	Encapsulated	None
2.0	1D1N002	631.00	N	115° C	180° C	Wall	No	Encapsulated	2, 1b
3.0	1D1N003	769.00	N	115° C	180° C	Wall	No	Encapsulated	2, 1b
5.0	1D1N005	968.00	N	115° C	180° C	Wall	No	Encapsulated	2, 1b
7.5	1D1N007	1405.00	N	115° C	180° C	Wall	No	Encapsulated	2, 1b
10.0	1D1N010	1603.00	N	115° C	180° C	Wall	No	Encapsulated	2, 1b
15	1D1N015	1868.00	N	115° C	180° C	Wall	No	Encapsulated	2, 1b
15	1D1Y015TP1	3562.00	Y	150° C	220° C	Floor & Wall	Yes	Ventilated	1, 2, 3, 4, 5
25	1D1Y025TP1	5283.00	Y	150° C	220° C	Floor & Wall	Yes	Ventilated	1, 2, 3, 4, 5
37.5	1D1Y037TP1	6720.00	Y	150° C	220° C	Floor & Wall	Yes	Ventilated	1, 2, 3, 4, 5
50	1D1Y050TP1	7737.00	Y	150° C	220° C	Floor & Wall	Yes	Ventilated	1, 2, 3, 4, 5
75	1D1Y075TP1	10254.00	Y	150° C	220° C	Floor	Yes	Ventilated	1, 2, 3, 5
100	1D1Y100TP1	21106.00	Y	150° C	220° C	Floor	Yes	Ventilated	1, 2, 3, 5
167	1D1Y167TP1	32804.00	Y	150° C	220° C	Floor	Yes	Ventilated	1, 2, 3, 5

277 Volts Primary, 120/240 Volts Secondary

3	1E1U003	755.00	U	115° C	180° C	Wall	No	Encapsulated	1b, 2, 3
5	1E1U005	978.00	U	115° C	180° C	Wall	No	Encapsulated	1b, 2, 3
7.5	1E1U007	1535.00	U	115° C	180° C	Wall	No	Encapsulated	1b, 2, 3
10	1E1U010	1804.00	U	115° C	180° C	Wall	No	Encapsulated	1b, 2, 3
15	1E1U015	5170.00	U	115° C	180° C	Wall	No	Encapsulated	1b, 2, 3
25	1E1U025	5311.00	U	115° C	180° C	Wall	No	Encapsulated	1b, 2, 3

480 Volts Primary, 120/240 Volts Secondary

3	1F1R003	774.00	R	115° C	180° C	Wall	No	Encapsulated	1b, 2, 3
5	1F1R005	968.00	R	115° C	180° C	Wall	No	Encapsulated	1b, 2, 3
7.5	1F1R007	1415.00	R	115° C	180° C	Wall	No	Encapsulated	1b, 2, 3
10	1F1R010	1598.00	R	115° C	180° C	Wall	No	Encapsulated	1b, 2, 3
15	1F1R015	1868.00	R	115° C	180° C	Wall	No	Encapsulated	1b, 2, 3
25	1F1R025	4314.00	R	115° C	180° C	Wall	No	Encapsulated	1b, 2, 3

Optional Modifications Table (Contact Sales office for List Price)

Optional (commonly used) Modifications	Catalog Suffix Code
1a. 115° C Rise	F
1b. 80° C Rise	B
2. Electrostatic Shield	ES
3. Copper Windings	C
4. Wall Mounting Brackets	W
5. Drip Shields	DS

Taps

Description	Designation
4-3% (2 FCAN, 2 FCBN)	J
2-3.5% (1 FCAN, 1 FCBN)	K
3-5% (1 FCAN, 2 FCBN)	M
None	N
2-5% FCBN	R
2-5% (1 FCAN, 1 FCBN)	S
4-2.5% (2 FCAN, 2 FCBN)	T
2-2.5% FCBN	U
4-2.5% FCBN	X
6-2.5% (2 FCAN, 4 FCBN)	Y

① Actual taps may vary based on volts/turn ratio.
 ② Wall designations for units having standard features.
 ③ For outdoor application. Ventilated transformers requiring drip shields/weathershields are UL listed

for outdoor use. No charge when requested at time of initial project order.
 ④ Encapsulated transformers are UL listed for indoor/outdoor use.

⑤ No charge when requested at time of initial project order.
 ⑥ Items marked floor and wall can be wall mounted with optional wall bracket identified with "W" suffix on catalog number.

Distribution Dry Type Transformers

Single Phase

Selection

KVA	Catalog Number	List Price \$	Taps ^①	Temperature Rise	Insulation	Mounting Type ^{②③}	Drip Shield Required ^③	Enclosure Style ^④	Optional Modifications
600 Volts Primary, 120/240 Volts Secondary									
3	1G1R003	780.00	R	115° C	180° C	Wall	No	Encapsulated	1b, 2, 3
5	1G1R005	1246.00	R	115° C	180° C	Wall	No	Encapsulated	1b, 2, 3
7.5	1G1R007	1759.00	R	115° C	180° C	Wall	No	Encapsulated	1b, 2, 3
10	1G1R010	1617.00	R	115° C	180° C	Wall	No	Encapsulated	1b, 2, 3
15	1G1R015	3665.00	R	115° C	180° C	Wall	No	Encapsulated	1b, 2, 3
25	1G1R025	5555.00	R, U	115° C	180° C	Wall	No	Encapsulated	1b, 2, 3
25	1G1Y025TP1	9545.00	Y, U	150° C	220° C	Floor & Wall	Yes	Ventilated	1, 2, 3, 4, 5
37.5	1G1Y037TP1	12171.00	Y, U	150° C	220° C	Floor & Wall	Yes	Ventilated	1, 2, 3, 4, 5
50	1G1Y050TP1	14122.00	Y, U	150° C	220° C	Floor & Wall	Yes	Ventilated	1, 2, 3, 4, 5
75	1G1Y075TP1	20472.00	Y	150° C	220° C	Floor	Yes	Ventilated	2, 3, 5
100	1G1Y100TP1	25821.00	Y	150° C	220° C	Floor	Yes	Ventilated	2, 3, 5
167	1G1Y167TP1	51057.00	Y	150° C	220° C	Floor	Yes	Ventilated	2, 3, 5

See page 7-6 for footnotes ①②③④ & ⑤

Overseas Model 190/200/208/220 x 380/400/416/440 Volts Primary, 120/240 Volts Secondary—1Ø, 50/60 Hz

1	1H1N001	828.00	N	115° C	180° C	Wall	No	Encapsulated	2
2	1H1N002	1211.00	N	115° C	180° C	Wall	No	Encapsulated	2
3	1H1N003	1570.00	N	115° C	180° C	Wall	No	Encapsulated	2
5	1H1N005	1976.00	N	115° C	180° C	Wall	No	Encapsulated	2
7.5	1H1N007	2613.00	N	115° C	180° C	Wall	No	Encapsulated	2
10	1H1N010	3138.00	N	115° C	180° C	Wall	No	Encapsulated	2
15	1H1N015	4030.00	N	115° C	180° C	Wall	No	Encapsulated	2, 3
25	1H1N025	6532.00	N	115° C	180° C	Wall	No	Encapsulated	2, 3
37.5	1H1N037	7368.00	N	150° C	220° C	Floor & Wall	Yes	Ventilated	2, 3, 5
50	1H1N050	8571.00	N	150° C	220° C	Floor & Wall	Yes	Ventilated	2, 3, 5
75	1H1N075	10179.00	N	150° C	220° C	Floor	Yes	Ventilated	2, 3, 5
100	1H1N100	11550.00	N	150° C	220° C	Floor	Yes	Ventilated	2, 3, 5

Overseas Model 190/208/220/240 x 380/416/440/480 Volts Primary, 120/240 Volts Secondary—1Ø, 50/60 Hz

1	1X1N001	828.00	N	115° C	180° C	Wall	No	Encapsulated	2
2	1X1N002	1211.00	N	115° C	180° C	Wall	No	Encapsulated	2
3	1X1N003	1570.00	N	115° C	180° C	Wall	No	Encapsulated	2
5	1X1N005	1976.00	N	115° C	180° C	Wall	No	Encapsulated	2
7.5	1X1N007	2613.00	N	115° C	180° C	Wall	No	Encapsulated	2
10	1X1N010	3138.00	N	115° C	180° C	Wall	No	Encapsulated	2
15	1X1N015	4030.00	N	115° C	180° C	Wall	No	Encapsulated	2, 3
25	1X1N025	6532.00	N	115° C	180° C	Wall	No	Encapsulated	2, 3

Overseas Model 190/200/208/220 x 380/400/416/440 Volts Primary, 110/220 Volts Secondary—1Ø, 50/60 Hz

1	1H8N001	828.00	N	115° C	180° C	Wall	No	Encapsulated	2
2	1H8N002	1211.00	N	115° C	180° C	Wall	No	Encapsulated	2
3	1H8N003	1570.00	N	115° C	180° C	Wall	No	Encapsulated	2
5	1H8N005	1976.00	N	115° C	180° C	Wall	No	Encapsulated	2
7.5	1H8N007	2613.00	N	115° C	180° C	Wall	No	Encapsulated	2

Notice: CE mark is included on sizes 1 through 25KVA on all overseas models.

Optional Modifications Table (Contact Sales office for List Price)

Optional (commonly used) Modifications	Catalog Suffix Code
1a. 115° C Rise	F
1b. 80° C Rise	B
2. Electrostatic Shield	ES
3. Copper Windings	C
4. Wall Mounting Brackets	W
5. Drip Shields	DS

Taps

Description	Designation
4-3% (2 FCAN, 2 FCBN)	J
2-3.5% (1 FCAN, 1 FCBN)	K
3-5% (1 FCAN, 2 FCBN)	M
None	N
2-5% FCBN	R
2-5% (1 FCAN, 1 FCBN)	S
4-2.5% (2 FCAN, 2 FCBN)	T
2-2.5% FCBN	U
4-2.5% FCBN	X
6-2.5% (2 FCAN, 4 FCBN)	Y

Distribution Dry Type Transformers

Three Phase

Selection

KVA	Catalog Number	List Price \$	Taps ^①	Temperature Rise	Insulation	Mounting Type ^{②③}	Drip Shield Required ^③	Enclosure Style ^④	Optional Modifications
-----	----------------	---------------	-------------------	------------------	------------	-----------------------------	-----------------------------------	------------------------------	------------------------

480 Volts Δ Primary, 240 Volts Δ Secondary With 120 Volt Tap On B Phase^⑤

15	3F1Y015TP1	4204.00	Y	150° C	220° C	Floor & Wall	Yes	Ventilated	1, 2, 3, 4, 5
30	3F1Y030TP1	6562.00	Y	150° C	220° C	Floor & Wall	Yes	Ventilated	1, 2, 3, 4, 5
45	3F1Y045TP1	6648.00	Y	150° C	220° C	Floor & Wall	Yes	Ventilated	1, 2, 3, 4, 5
75	3F1Y075TP1	9606.00	Y	150° C	220° C	Floor	Yes	Ventilated	1, 2, 3, 5, 7
112.5	3F1Y112TP1	13152.00	Y	150° C	220° C	Floor	Yes	Ventilated	1, 2, 3, 5, 7
150	3F1Y150TP1	15852.00	Y	150° C	220° C	Floor	Yes	Ventilated	1, 2, 3, 5, 7
225	3F1Y225TP1	22217.00	Y	150° C	220° C	Floor	Yes	Ventilated	1, 2, 3, 5, 7
300	3F1Y300TP1	29647.00	Y	150° C	220° C	Floor	Yes	Ventilated	1, 2, 3, 5, 7
500	3F1Y500TP1	59077.00	Y	150° C	220° C	Floor	Yes	Ventilated	1, 2, 3, 5, 7
750	3F1Y750TP1	93911.00	Y	150° C	220° C	Floor	Yes	Ventilated	1a, 2, 3

480 Volts Δ Primary, 240 Volts Δ Secondary

3	3F2R003 ^⑦	2094.00	R	115° C	180° C	Wall	No	Encapsulated	1b, 2, 3
6	3F2R006 ^⑦	2774.00	R	115° C	180° C	Wall	No	Encapsulated	1b, 2, 3
9	3F2R009 ^⑦	3457.00	R	115° C	180° C	Wall	No	Encapsulated	1b, 2, 3
15	3F2R015 ^⑦	5035.00	R	115° C	180° C	Wall	No	Encapsulated	1b, 2, 3

480 Volts Δ Primary, 208Y/120 Volts Secondary

3	3F3R003	1807.00	R	115° C	180° C	Wall	No	Encapsulated	1b, 2, 3
6	3F3R006	1899.00	R	115° C	180° C	Wall	No	Encapsulated	1b, 2, 3
9	3F3R009	2735.00	R	115° C	180° C	Wall	No	Encapsulated	1b, 2, 3
15	3F3R015	2943.00	R	115° C	180° C	Wall	No	Encapsulated	1b, 2, 3
15	3F3Y015TP1	4246.00	Y	150° C	220° C	Floor & Wall	Yes	Ventilated	1, 2, 3, 4, 5, 6, 7
30	3F3Y030TP1	5467.00	Y	150° C	220° C	Floor & Wall	Yes	Ventilated	1, 2, 3, 4, 5, 6, 7
45	3F3Y045TP1	6494.00	Y	150° C	220° C	Floor & Wall	Yes	Ventilated	1, 2, 3, 4, 5, 6, 7
75	3F3Y075TP1	9244.00	Y	150° C	220° C	Floor & Wall ^⑧	Yes	Ventilated	1, 2, 3, 5, 6, 7
112.5	3F3Y112TP1	11607.00	Y	150° C	220° C	Floor	Yes	Ventilated	1, 2, 3, 5, 6, 7
150	3F3Y150TP1	15472.00	Y	150° C	220° C	Floor	Yes	Ventilated	1, 2, 3, 5, 6, 7
225	3F3Y225TP1	19634.00	Y	150° C	220° C	Floor	Yes	Ventilated	1, 2, 3, 5, 6, 7
300	3F3Y300TP1	27092.00	Y	150° C	220° C	Floor	Yes	Ventilated	1, 2, 3, 5, 6, 7
500	3F3Y500TP1	41465.00	Y	150° C	220° C	Floor	Yes	Ventilated	1, 2, 3, 5, 6, 7
750	3F3Y750TP1	92836.00	Y	150° C	220° C	Floor	Yes	Ventilated	1, 2, 3, 7
1000	3F3S000TP1	91694.00	J, Y, K, S	150° C	220° C	Floor	Yes	Ventilated	None

KVA	Catalog Number	List Price \$	Taps ^①	Temperature Rise	Insulation	Mounting Type	Drip Shield Required	Optional Modifications	Avg. Sound Level
-----	----------------	---------------	-------------------	------------------	------------	---------------	----------------------	------------------------	------------------

Totally Enclosed Transformers, Indoor/Outdoor Use^⑥

480 Volts Δ Primary, 208Y/120 Volts Secondary

15	3F3Y015TE	7260.00	Y	150° C	220° C	Floor	No	None	45dB
30	3F3Y030TE	10382.00	Y	150° C	220° C	Floor	No	None	45dB
45	3F3Y045TE	12171.00	Y	150° C	220° C	Floor	No	None	50dB
75	3F3Y075TE	17130.00	Y	150° C	220° C	Floor	No	None	50dB
112.5	3F3Y112TE	12626.00	Y	150° C	220° C	Floor	No	None	55dB
150	3F3Y150TE	15862.00	Y	150° C	220° C	Floor	No	None	55dB

480 Volts Δ Primary, 240 Volts Δ Secondary with 120V Lighting Tap on B Phase^⑤

15	3F1Y015TE	7260.00	Y	150° C	220° C	Floor	No	None	45dB
30	3F1Y030TE	10382.00	Y	150° C	220° C	Floor	No	None	45dB
45	3F1Y045TE	12171.00	Y	150° C	220° C	Floor	No	None	50dB
75	3F1Y075TE	16981.00	Y	150° C	220° C	Floor	No	None	50dB
112.5	3F1Y112TE	23718.00	Y	150° C	220° C	Floor	No	None	55dB
150	3F1Y150TE	30907.00	Y	150° C	220° C	Floor	No	None	55dB

Optional Modifications Table (Contact Sales office for List Price)

Optional (commonly used) Modifications	Catalog Suffix Code
1a. 115°C Rise	F
1b. 80°C Rise	B
2. Electrostatic Shield	ES
3. Copper Windings	C
4. Wall Mounting Brackets	W
5. Drip Shields	DS
6. Low noise—3dB below std.	LN3
7. Super Energy Efficient	S [®]

Taps

Description	Designation
4-3% (2 FCAN, 2 FCBN)	J
2-3.5% (1 FCAN, 1 FCBN)	K
3-5% (1 FCAN, 2 FCBN)	M
None	N
2-5% FCBN	R
2-5% (1 FCAN, 1 FCBN)	S
4-2.5% (2 FCAN, 2 FCBN)	T
2-2.5% FCBN	U
4-2.5% FCBN	X
6-2.5% (2 FCAN, 4 FCBN)	Y

① Actual taps may vary based on volts/turn ratio.

② Wall designations for units having standard features.

③ For outdoor application. Ventilated transformers requiring drip shields are UL listed for outdoor use.

④ Encapsulated transformers are UL listed for indoor/outdoor use (2.5% on each side of lighting tap).

⑤ Reduced capacity 1-phase tap—When utilizing 1-phase

tap at 5%, the 3-phase load is reduced to 85% max. (5% reduction on 3 coils). 10% of rated KVA absolute maximum (evenly balanced on each side of lighting tap). When utilizing 1-phase tap at 10%, the 3-phase load is reduced to 70% max. (10% reduction on 3 coils).

⑥ No charge when requested at time of initial project order.

⑦ 240 volt secondary (3F2) is available in 3-phase 3 to 15KVA only.

⑧ TE units will have inrush equal to 2 sizes larger than rated KVA.

⑨ Items marked floor and wall can be wall mounted with optional wall bracket identified with "W" suffix on catalog number.

⑩ Wall mounting for 150°C rise aluminum only.

⑪ TP1S "S" features are described on page 7-14.

Distribution Dry Type Transformers

Three Phase

Selection

KVA	Catalog Number	List Price \$	Taps ^①	Temperature Rise	Insulation	Mounting Type ^{②⑦}	Drip Shield Required ^③	Enclosed Type ^④	Optional Modifications
-----	----------------	---------------	-------------------	------------------	------------	-----------------------------	-----------------------------------	----------------------------	------------------------

480 Volts Δ Primary, 480Y/277 Volts Secondary

15	3F5R015	4660.00	R	115° C	180° C	Wall	No	Encapsulated	1b, 2, 3
15	3F5Y015TP1	3952.00	Y	150° C	220° C	Floor & Wall	Yes	Ventilated	1, 2, 3, 4, 5, 7
30	3F5Y030TP1	33766.00	Y	150° C	220° C	Floor & Wall	Yes	Ventilated	1, 2, 3, 4, 5, 7
45	3F5Y045TP1	8191.00	Y	150° C	220° C	Floor & Wall	Yes	Ventilated	1, 2, 3, 4, 5, 7
75	3F5Y075TP1	12353.00	Y	150° C	220° C	Floor	Yes	Ventilated	1, 2, 3, 5, 7
112.5	3F5Y112TP1	17122.00	Y	150° C	220° C	Floor	Yes	Ventilated	1, 2, 3, 5, 7
150	3F5Y150TP1	15157.00	Y	150° C	220° C	Floor	Yes	Ventilated	1, 2, 3, 5, 7
225	3F5Y225TP1	30016.00	Y	150° C	220° C	Floor	Yes	Ventilated	1, 2, 3, 5, 7
300	3F5Y300TP1	43146.00	Y	150° C	220° C	Floor	Yes	Ventilated	1, 2, 3, 5, 7
500	3F5Y500TP1	78455.00	Y	150° C	220° C	Floor	Yes	Ventilated	1, 2, 3, 5, 7

3-Phase 480 Δ — 208Y/120 K-4 (50% Non-Linear Load)^⑤

15	3F3Y015K4TP1	5480.00	Y	150° C	220° C	Floor	Yes	Ventilated	1, 3, 4, 5, 6
30	3F3Y030K4TP1	5903.00	Y	150° C	220° C	Floor	Yes	Ventilated	1, 3, 4, 5, 6
45	3F3Y045K4TP1	6945.00	Y	150° C	220° C	Floor	Yes	Ventilated	1, 3, 4, 5, 6
75	3F3Y075K4TP1	10012.00	Y	150° C	220° C	Floor	Yes	Ventilated	1, 3, 5, 6
112.5	3F3Y112K4TP1	13214.00	Y	150° C	220° C	Floor	Yes	Ventilated	1, 3, 5, 6
150	3F3Y150K4TP1	17173.00	Y	150° C	220° C	Floor	Yes	Ventilated	1, 3, 5, 6
225	3F3Y225K4TP1	23977.00	Y	150° C	220° C	Floor	Yes	Ventilated	1, 3, 5, 6
300	3F3Y300K4TP1	32603.00	Y	150° C	220° C	Floor	Yes	Ventilated	1, 3, 5, 6
500	3F3Y500K4TP1	81244.00	Y	150° C	220° C	Floor	Yes	Ventilated	1, 3, 5, 6

3-Phase 480 Δ — 208Y/120 K-13 (100% Non-Linear Load)^⑤

15	3F3Y015K13TP1	6181.00	Y	150° C	220° C	Floor	Yes	Ventilated	1, 3, 4, 5, 6, 7
30	3F3Y030K13TP1	6659.00	Y	150° C	220° C	Floor	Yes	Ventilated	1, 3, 4, 5, 6, 7
45	3F3Y045K13TP1	7766.00	Y	150° C	220° C	Floor	Yes	Ventilated	1, 3, 4, 5, 6, 7
75	3F3Y075K13TP1	11103.00	Y	150° C	220° C	Floor	Yes	Ventilated	1, 3, 5, 6, 7
112.5	3F3Y112K13TP1	14912.00	Y	150° C	220° C	Floor	Yes	Ventilated	1, 3, 5, 6, 7
150	3F3Y150K13TP1	19380.00	Y	150° C	220° C	Floor	Yes	Ventilated	1, 3, 5, 6, 7
225	3F3Y225K13TP1	27282.00	Y	150° C	220° C	Floor	Yes	Ventilated	1, 3, 5, 6, 7
300	3F3Y300K13TP1	36776.00	Y	150° C	220° C	Floor	Yes	Ventilated	1, 3, 5, 6, 7
500	3F3Y500K13TP1	96114.00	Y	150° C	220° C	Floor	Yes	Ventilated	1, 3, 5, 6, 7

3-Phase 480 Δ — 208Y/120 K-20 (125% Non-Linear Load)^⑤

15	3F3Y015K20TP1	6659.00	Y	150° C	220° C	Floor	Yes	Ventilated	1, 3, 4, 5
30	3F3Y030K20TP1	9193.00	Y	150° C	220° C	Floor	Yes	Ventilated	1, 3, 4, 5
45	3F3Y045K20TP1	10870.00	Y	150° C	220° C	Floor	Yes	Ventilated	1, 3, 4, 5
75	3F3Y075K20TP1	15244.00	Y	150° C	220° C	Floor	Yes	Ventilated	1, 3, 5
112.5	3F3Y112K20TP1	23304.00	Y	150° C	220° C	Floor	Yes	Ventilated	1, 3, 5
150	3F3Y150K20TP1	25308.00	Y	150° C	220° C	Floor	Yes	Ventilated	1, 3, 5
225	3F3Y225K20TP1	36122.00	Y	150° C	220° C	Floor	Yes	Ventilated	1, 3, 5
300	3F3Y300K20TP1	53724.00	Y	150° C	220° C	Floor	Yes	Ventilated	1, 3, 5
500	3F3Y500K20TP1	105122.00	Y	150° C	220° C	Floor	Yes	Ventilated	1, 3, 5

3-Phase 480 Δ — 208Y/120 K-30 (150% Non-Linear Load)^⑤

15	3F3Y015K30TP1	CSO	Y	150° C	220° C	Floor	Yes	Ventilated	1, 3, 4, 5
30	3F3Y030K30TP1	8451.00	Y	150° C	220° C	Floor	Yes	Ventilated	1, 3, 4, 5
45	3F3Y045K30TP1	11749.00	Y	150° C	220° C	Floor	Yes	Ventilated	1, 3, 4, 5
75	3F3Y075K30TP1	CSO	Y	150° C	220° C	Floor	Yes	Ventilated	1, 3, 5
112.5	3F3Y112K30TP1	28298.00	Y	150° C	220° C	Floor	Yes	Ventilated	1, 3, 5
150	3F3Y150K30TP1	CSO	Y	150° C	220° C	Floor	Yes	Ventilated	1, 3, 5
225	3F3Y225K30TP1	CSO	Y	150° C	220° C	Floor	Yes	Ventilated	1, 3, 5
300	3F3Y300K30TP1	CSO	Y	150° C	220° C	Floor	Yes	Ventilated	1, 3, 5
500	3F3Y500K30TP1	CSO	Y	150° C	220° C	Floor	Yes	Ventilated	1, 3, 5

Optional Modifications Table (Contact Sales office for List Price)

Optional (commonly used) Modifications	Catalog Suffix Code
1a. 115°C Rise	F
1b. 80°C Rise	B
2. Electrostatic Shield	ES
3. Copper Windings	C
4. Wall Mounting Brackets	W
5. Drip Shields	DS
6. Low noise — 3dB below std.	LN3
7. Super Energy Efficient	S [®]

Taps

Description	Designation
4-3% (2 FCAN, 2 FCBN)	J
2-3.5% (1 FCAN, 1 FCBN)	K
3-5% (1 FCAN, 2 FCBN)	M
None	N
2-5% FCBN	R
2-5% (1 FCAN, 1 FCBN)	S
4-2.5% (2 FCAN, 2 FCBN)	T
2-2.5% FCBN	U
4-2.5% FCBN	X
6-2.5% (2 FCAN, 4 FCBN)	Y

① Actual taps may vary based on volts/turn ratio.

② Wall designations for units having standard features.

③ For outdoor application. Ventilated transformers requiring drip shields are UL listed for outdoor use.

④ Encapsulated transformers are UL listed for indoor/outdoor use. 9 & 15kva with R taps also available in ventilated enclosures.

⑤ K-Factor transformers equipped with electrostatic shield and 200% neutral as standard features.

⑥ No charge when requested at time of initial project order.

⑦ Items marked floor and wall can be wall mounted with optional wall bracket identified with "W" suffix on catalog number.

⑧ TP1S features are described on page 7-14.

Distribution Dry Type Transformers

Three Phase

Selection

KVA	Catalog Number	List Price \$	Taps ^①	Temperature Rise	Insulation	Mounting Type ^{②③}	Drip Shield Required ^④	Enclosure Style ^⑤	Optional Modifications
-----	----------------	---------------	-------------------	------------------	------------	-----------------------------	-----------------------------------	------------------------------	------------------------

208 Volts Δ Primary, 208Y/120 Volts Secondary

3	3B3R003	1923.00	R	115° C	180° C	Wall	No	Encapsulated	1b, 2, 3
6	3B3R006	3055.00	R	115° C	180° C	Wall	No	Encapsulated	1b, 2, 3
9	3B3R009	4166.00	R	115° C	180° C	Wall	No	Encapsulated	1b, 2, 3
15	3B3R015	5140.00	R	115° C	180° C	Wall	No	Encapsulated	1b, 2, 3
15	3B3Y015TP1	4038.00	Y, T	150° C	220° C	Floor & Wall	Yes	Ventilated	1, 2, 3, 4, 5
30	3B3Y030TP1	6953.00	Y, T	150° C	220° C	Floor & Wall	Yes	Ventilated	1, 2, 3, 4, 5
45	3B3Y045TP1	21463.00	Y, T	150° C	220° C	Floor & Wall	Yes	Ventilated	1, 2, 3, 4, 5
75	3B3Y075TP1	26602.00	Y, T	150° C	220° C	Floor	Yes	Ventilated	1, 2, 3, 5
112.5	3B3Y112TP1	33138.00	Y, T	150° C	220° C	Floor	Yes	Ventilated	1, 2, 3, 5
150	3B3Y150TP1	19676.00	Y, T, M	150° C	220° C	Floor	Yes	Ventilated	1, 2, 3, 5
225	3B3S225TP1	32520.00	R, S	150° C	220° C	Floor	Yes	Ventilated	1, 2, 3, 5
300	3B3S300TP1	46740.00	R, S	150° C	220° C	Floor	Yes	Ventilated	1, 2, 3, 5
500	3B3S500TP1	84992.00	R, S	150° C	220° C	Floor	Yes	Ventilated	1, 2, 3, 5

208 Volt Δ Primary, 240 Δ Secondary with 120 Volt TAP on B Phase^②

15	3B1Y015TP1	4165.00	Y	150° C	220° C	Floor & Wall	Yes	Ventilated	1, 2, 3, 4, 5
30	3B1Y030TP1	9585.00	Y	150° C	220° C	Floor & Wall	Yes	Ventilated	1, 2, 3, 4, 5
45	3B1Y045TP1	12455.00	Y	150° C	220° C	Floor & Wall	Yes	Ventilated	1, 2, 3, 4, 5
75	3B1Y075TP1	19323.00	Y	150° C	220° C	Floor & Wall	Yes	Ventilated	1, 2, 3, 4, 5
112.5	3B1Y112TP1	24112.00	Y	150° C	220° C	Floor	Yes	Ventilated	1, 2, 3, 4, 5
150	3B1Y150TP1	28211.00	Y	150° C	220° C	Floor	Yes	Ventilated	1, 2, 3, 4, 5
225	3B1Y225TP1	37520.00	Y	150° C	220° C	Floor	Yes	Ventilated	1, 2, 3, 4, 5

208 Volts Δ Primary, 480Y/277 Volts Secondary

9	3B5R009	4176.00	R	115° C	180° C	Wall	No	Encapsulated	1b, 2, 3
15	3B5R015	4934.00	R	115° C	180° C	Wall	No	Encapsulated	1b, 2, 3
30	3B5R030TP1	6983.00	R	150° C	220° C	Floor & Wall	Yes	Ventilated	1, 2, 3, 4, 5
45	3B5R045TP1	8201.00	R	150° C	220° C	Floor & Wall	Yes	Ventilated	1, 2, 3, 4, 5
75	3B5R075TP1	11559.00	R	150° C	220° C	Floor	Yes	Ventilated	1, 2, 3, 5
112.5	3B5R112TP1	19146.00	R	150° C	220° C	Floor	Yes	Ventilated	1, 2, 3, 5
150	3B5R150TP1	19088.00	R	150° C	220° C	Floor	Yes	Ventilated	1, 2, 3, 5
225	3B5S225TP1	26527.00	S	150° C	220° C	Floor	Yes	Ventilated	1, 2, 3, 5
300	3B5S300TP1	65844.00	S	150° C	220° C	Floor	Yes	Ventilated	1, 2, 3, 5
500	3B5S500TP1	95283.00	S	150° C	220° C	Floor	Yes	Ventilated	1, 2, 3, 5

240 Volts Δ Primary, 208Y/120 Volts Secondary

15	3C3Y015TP1	7780.00	Y	150° C	220° C	Floor & Wall	Yes	Ventilated	1, 2, 3, 4, 5
30	3C3Y030TP1	13383.00	Y	150° C	220° C	Floor & Wall	Yes	Ventilated	1, 2, 3, 4, 5
45	3C3Y045TP1	7871.00	Y	150° C	220° C	Floor & Wall	Yes	Ventilated	1, 2, 3, 4, 5
75	3C3Y075TP1	11683.00	Y	150° C	220° C	Floor	Yes	Ventilated	1, 2, 3, 5
112.5	3C3Y112TP1	15676.00	Y	150° C	220° C	Floor	Yes	Ventilated	1, 2, 3, 5
150	3C3Y150TP1	17465.00	Y	150° C	220° C	Floor	Yes	Ventilated	1, 2, 3, 5
225	3C3S225TP1	32520.00	S	150° C	220° C	Floor	Yes	Ventilated	1, 2, 3, 5
300	3C3S300TP1	46740.00	S	150° C	220° C	Floor	Yes	Ventilated	1, 2, 3, 5
500	3C3S500TP1	56332.00	S	150° C	220° C	Floor	Yes	Ventilated	1, 2, 3, 5

240 Volts Δ Primary, 480Y/277 Volts Secondary

15	3C5Y015TP1	7780.00	Y	150° C	220° C	Floor & Wall	Yes	Ventilated	1, 2, 3, 4, 5
30	3C5Y030TP1	9585.00	Y	150° C	220° C	Floor & Wall	Yes	Ventilated	1, 2, 3, 4, 5
45	3C5Y045TP1	12455.00	Y	150° C	220° C	Floor & Wall	Yes	Ventilated	1, 2, 3, 4, 5
75	3C5Y075TP1	17138.00	Y	150° C	220° C	Floor	Yes	Ventilated	1, 2, 3, 5
112.5	3C5Y112TP1	21398.00	Y	150° C	220° C	Floor	Yes	Ventilated	1, 2, 3, 5
150	3C5Y150TP1	28211.00	Y	150° C	220° C	Floor	Yes	Ventilated	1, 2, 3, 5
225	3C5S225TP1	45801.00	S	150° C	220° C	Floor	Yes	Ventilated	1, 2, 3, 5
300	3C5S300TP1	65844.00	S	150° C	220° C	Floor	Yes	Ventilated	1, 2, 3, 5
500	3C5S500TP1	84992.00	S	150° C	220° C	Floor	Yes	Ventilated	1, 2, 3, 5

Optional Modifications Table (Contact Sales office for List Price)

Optional (commonly used) Modifications	Catalog Suffix Code
1a. 115° C Rise	F
1b. 80° C Rise	B
2. Electrostatic Shield	ES
3. Copper Windings	C
4. Wall Mounting Brackets	W
5. Drip Shields	DS
6. Low noise—3dB below std.	LN3

Taps

Description	Designation
4-3% (2 FCAN, 2 FCBN)	J
2-3.5% (1 FCAN, 1 FCBN)	K
3-5% (1 FCAN, 2 FCBN)	M
None	N
2-5% FCBN	R
2-5% (1 FCAN, 1 FCBN)	S
4-2.5% (2 FCAN, 2 FCBN)	T
2-2.5% FCBN	U
4-2.5% FCBN	X
6-2.5% (2 FCAN, 4 FCBN)	Y

- ① Actual taps may vary based on volts/turn ratio.
- ② Wall designations for units having standard features.
- ③ For outdoor application. Ventilated transformers requiring drip shields are UL listed for outdoor use.
- ④ Encapsulated transformers are UL listed for indoor/outdoor use. 9 & 15kva with R taps also available in ventilated enclosures.

- ⑤ No charge when requested at time of initial project order.
- ⑥ Items marked floor and wall can be wall mounted with optional wall bracket identified with "W" suffix on catalog number.

- ⑦ Reduced capacity 1-phase tap—When utilizing 1-phase tap at 5%, the 3-phase load is reduced to 85% max. (5% reduction on 3 coils). 10% of rated KVA absolute maximum (evenly balanced on each side of lighting tap). When utilizing 1-phase tap at 10%, the 3-phase load is reduced to 70% max. (10% reduction on 3 coils).

Distribution Dry Type Transformers

Three Phase

Selection

KVA	Catalog Number	List Price \$	Taps ^①	Temperature Rise	Insulation	Mounting Type ^{②⑦}	Drip Shield Required ^③	Enclosure Style ^④	Optional Modifications
-----	----------------	---------------	-------------------	------------------	------------	-----------------------------	-----------------------------------	------------------------------	------------------------

600 Volts Δ Primary, 208Y/120 Volts Secondary

3	3G3R003	3476.00	R	115° C	180° C	Wall	No	Encapsulated	1b, 2, 3
6	3G3R006	2541.00	R	115° C	180° C	Wall	No	Encapsulated	1b, 2, 3
9	3G3R009	3137.00	R	115° C	180° C	Wall	No	Encapsulated	1b, 2, 3
15	3G3R015	4846.00	R	115° C	180° C	Wall	No	Encapsulated	1b, 2, 3
15	3G3Y015TP1	6740.00	Y	150° C	220° C	Floor & Wall	Yes	Ventilated	1, 2, 3, 4, 5
30	3G3Y030TP1	8309.00	Y	150° C	220° C	Floor & Wall	Yes	Ventilated	1, 2, 3, 4, 5
45	3G3Y045TP1	10797.00	Y	150° C	220° C	Floor & Wall	Yes	Ventilated	1, 2, 3, 4, 5
75	3G3Y075TP1	14854.00	Y	150° C	220° C	Floor	Yes	Ventilated	1, 2, 3, 5
112.5	3G3Y112TP1	18545.00	Y	150° C	220° C	Floor	Yes	Ventilated	1, 2, 3, 5
150	3G3Y150TP1	24455.00	Y	150° C	220° C	Floor	Yes	Ventilated	1, 2, 3, 5
225	3G3Y225TP1	32520.00	Y	150° C	220° C	Floor	Yes	Ventilated	1, 2, 3, 5
300	3G3Y300TP1	46740.00	Y	150° C	220° C	Floor	Yes	Ventilated	1, 2, 3, 5
500	3G3Y500TP1	84992.00	Y	150° C	220° C	Floor	Yes	Ventilated	1, 2, 3, 5

600 Volts Δ Primary, 480Y/277 Volts Secondary

3	3G5R003	1819.00	R	115° C	180° C	Wall	No	Encapsulated	2
6	3G5R006	3009.00	R	115° C	180° C	Wall	No	Encapsulated	2
9	3G5R009	4684.00	R	115° C	180° C	Wall	No	Encapsulated	2
15	3G5R015	8424.00	R	115° C	180° C	Wall	No	Encapsulated	2
15	3G5Y015TP1	7780.00	Y	150° C	220° C	Floor & Wall	Yes	Ventilated	2, 4, 5
30	3G5Y030TP1	9585.00	Y	150° C	220° C	Floor & Wall	Yes	Ventilated	2, 4, 5
45	3G5Y045TP1	12455.00	Y	150° C	220° C	Floor & Wall	Yes	Ventilated	2, 4, 5
75	3G5Y075TP1	17138.00	Y	150° C	220° C	Floor	Yes	Ventilated	1, 2, 3, 5
112.5	3G5Y112TP1	30128.00	Y	150° C	220° C	Floor	Yes	Ventilated	1, 2, 3, 5
150	3G5Y150TP1	28211.00	Y	150° C	220° C	Floor	Yes	Ventilated	1, 2, 3, 5
225	3G5Y225TP1	37520.00	Y	150° C	220° C	Floor	Yes	Ventilated	1, 2, 3, 5
300	3G5Y300TP1	52867.00	Y	150° C	220° C	Floor	Yes	Ventilated	1, 2, 3, 5
500	3G5Y500TP1	98065.00	Y	150° C	220° C	Floor	Yes	Ventilated	1, 2, 3, 5

Dual Purpose Auto Transformers^⑥

KVA		Catalog Number	List Price \$	Taps ^①	Temperature Rise	Insulation	Mounting Type ^②	Drip Shield Required ^③	Enclosure Style ^④	Optional Modifications
600V Pri 480V Sec	480V Pri 380V Sec									

600 Volts Primary, 480 Volts Secondary 3Ø 60 Hz &— 480 Volts Primary 380 Volts Secondary 3Ø 50/60 Hz Alternate Rating

15	12	3G4R015A	2008.00	R	115° C	180° C	Wall	No	Encapsulated	—
30	24	3G4R030A	2549.00	R	115° C	180° C	Wall	No	Encapsulated	—
45	36	3G4R045A	3816.00	R	115° C	180° C	Wall	No	Encapsulated	—
75	60	3G4R075A	5552.00	R	115° C	180° C	Floor & Wall	No	Encapsulated	4
112.5	90	3G4R112A	6603.00	R	150° C	220° C	Floor & Wall	Yes	Ventilated	4, 5
150	120	3G4R150A	7655.00	R	150° C	220° C	Floor & Wall	Yes	Ventilated	4, 5
225	180	3G4R225A	9240.00	R	150° C	220° C	Floor & Wall	Yes	Ventilated	4, 5
300	240	3G4R300A	12020.00	R	150° C	220° C	Floor & Wall	Yes	Ventilated	4, 5
500	400	3G4R500A	16155.00	R	150° C	220° C	Floor & Wall	Yes	Ventilated	5

Optional Modifications Table (Contact Sales office for List Price)

Optional (commonly used) Modifications	Catalog Suffix Code
1a. 115° C Rise	F
1b. 80° C Rise	B
2. Electrostatic Shield	ES
3. Copper Windings	C
4. Wall Mounting Brackets	W
5. Drip Shields	DS

Taps

Description	Designation
4-3% (2 FCAN, 2 FCBN)	J
2-3.5% (1 FCAN, 1 FCBN)	K
3-5% (1 FCAN, 2 FCBN)	M
None	N
2-5% FCBN	R
2-5% (1 FCAN, 1 FCBN)	S
4-2.5% (2 FCAN, 2 FCBN)	T
2-2.5% FCBN	U
4-2.5% FCBN	X
6-2.5% (2 FCAN, 4 FCBN)	Y

① Actual taps may vary based on volts/turn ratio.

② Wall designations for units having standard features.

③ For outdoor application. Ventilated transformers requiring drip shields are UL listed for outdoor use.

④ Encapsulated transformers are UL listed for indoor/outdoor use.

⑤ No charge when requested at time of initial project order.

⑥ If used on unbalanced loads, these auto transformers will need to be used on a 4-wire system with the supply neutral connected to the transformer. If used on motor

loads, then they may be used on a 3-wire system without a neutral or fourth wire. Review in NEC 450-4 and 450-5.

⑦ Items marked floor and wall can be wall mounted with optional wall bracket identified with "W" suffix on catalog number.

Distribution Dry Type Transformers

Three Phase

Selection

Isolation & Filtering Transformers

The Siemens "XES" models are specifically designed to protect sensitive equipment from surges, spikes and line noise. These designs are available with

either 208 volt or 480 volt primary and 280Y/120 volt secondary up to 225 kVA. All units have spike/surge protection on the primary side and low pass filters on the secondary. The combination of these components and the electrostatic

shielding provide excellent transverse mode noise attenuation of 60 db. Additionally the common mode noise attenuation of 120 db will increase protection from line noise, spikes and surges.

Shielded Isolation with Filter Capacitors and Surge Suppression ("XES" Models)

KVA	Catalog Number	List Price \$	Taps ^①	Temperature Rise	Insulation	Mounting Type ^③	Drip Shield Required ^②	Enclosure Style	Optional Modifications
480 Volts Δ Primary, 208Y/120 Volts Secondary									
15	3F3Y015XESTP1	6504.00	Y	150° C	220° C	Floor & Wall	Yes	Ventilated	1, 3, 4, 5
30	3F3Y030XESTP1	9008.00	Y	150° C	220° C	Floor & Wall	Yes	Ventilated	1, 3, 4, 5
45	3F3Y045XESTP1	11000.00	Y	150° C	220° C	Floor & Wall	Yes	Ventilated	1, 3, 4, 5
75	3F3Y075XESTP1	16130.00	Y	150° C	220° C	Floor & Wall	Yes	Ventilated	1, 3, 5
112.5	3F3Y112XESTP1	18000.00	Y	150° C	220° C	Floor	Yes	Ventilated	1a, 3, 5

208 Volts Δ Primary, 208Y/120 Volts Secondary

15	3B3Y015XESTP1	6504.00	Y	150° C	220° C	Floor & Wall	Yes	Ventilated	1, 3, 4, 5
30	3B3Y030XESTP1	9008.00	Y	150° C	220° C	Floor & Wall	Yes	Ventilated	1, 3, 4, 5
45	3B3Y045XESTP1	11000.00	Y	150° C	220° C	Floor & Wall	Yes	Ventilated	1, 3, 4, 5
75	3B3Y075XESTP1	16130.00	Y	150° C	220° C	Floor & Wall	Yes	Ventilated	1, 3, 5
112.5	3B3Y112XESTP1	18000.00	Y	150° C	220° C	Floor	Yes	Ventilated	1a, 3, 5

240 Volts Δ Primary, 208Y/120 Volts Secondary

15	3C3Y015XESTP1	6504.00	Y	150° C	220° C	Floor & Wall	Yes	Ventilated	1, 3, 4, 5
30	3C3Y030XESTP1	9008.00	Y	150° C	220° C	Floor & Wall	Yes	Ventilated	1, 3, 4, 5
45	3C3Y045XESTP1	11000.00	Y	150° C	220° C	Floor & Wall	Yes	Ventilated	1, 3, 4, 5
75	3C3Y075XESTP1	16130.00	Y	150° C	220° C	Floor & Wall	Yes	Ventilated	1, 3, 5
112.5	3C3Y112XESTP1	18000.00	Y	150° C	220° C	Floor	Yes	Ventilated	1a, 3, 5

Taps (See page 7-11)

Motor Drive Isolation

Three Phase 60HZ Motor Drive Isolation Transformers

KVA ^⑤	Motor H.P. ^④	Catalog Number	List Price \$	Standard Taps	Temperature Rise	Insulation	Mounting Type	Drip Shield Required ^②
7.5	3 & 5	DT () 007	3045.00	2-5% FCAN/BN	115° C	180° C	Floor & Wall	Yes
11	7.5	DT () 011	5492.00	2-5% FCAN/BN	115° C	180° C	Floor & Wall	Yes
15	10	DT () 015	5008.00	2-5% FCAN/BN	150° C	220° C	Floor & Wall	Yes
20	15	DT () 020	5797.00	2-5% FCAN/BN	150° C	220° C	Floor & Wall	Yes
27	20	DT () 027	6902.00	2-5% FCAN/BN	150° C	220° C	Floor & Wall	Yes
34	25	DT () 034	7659.00	2-5% FCAN/BN	150° C	220° C	Floor & Wall	Yes
40	30	DT () 040	8073.00	2-5% FCAN/BN	150° C	220° C	Floor & Wall	Yes
51	40	DT () 051	9163.00	2-5% FCAN/BN	150° C	220° C	Floor & Wall	Yes
63	50	DT () 063	10650.00	2-5% FCAN/BN	150° C	220° C	Floor	Yes
75	60	DT () 075	12130.00	2-5% FCAN/BN	150° C	220° C	Floor	Yes
93	75	DT () 093	12366.00	2-5% FCAN/BN	150° C	220° C	Floor	Yes
118	100	DT () 118	13114.00	2-5% FCAN/BN	150° C	220° C	Floor	Yes
145	125	DT () 145	15537.00	2-5% FCAN/BN	150° C	220° C	Floor	Yes
175	150	DT () 175	18626.00	2-5% FCAN/BN	150° C	220° C	Floor	Yes
220	200	DT () 220	23366.00	2-5% FCAN/BN	150° C	220° C	Floor	Yes
275	250	DT () 275	CSO	2-5% FCAN/BN	150° C	220° C	Floor	Yes
330	300	DT () 330	CSO	2-5% FCAN/BN	150° C	220° C	Floor	Yes
440	400	DT () 440	CSO	2-5% FCAN/BN	150° C	220° C	Floor	Yes
550	500	DT () 550	CSO	2-5% FCAN/BN	150° C	220° C	Floor	Yes
660	600	DT () 660	CSO	6.2% FCAN/BN	150° C	220° C	Floor	Yes

DT () Code	Primary Volts	Secondary Volts
18	208 Delta	208Y/120
20	208 Delta	230Y/133
21	208 Delta	460Y/266
22	230 Delta	230Y/133
24	230 Delta	460Y/266
30	380 Delta	460Y/266
42	460 Delta	230Y/133
44	460 Delta	460Y/266
45	460 Delta	380Y/220
52	575 Delta	230Y/133
54	575 Delta	460Y/266

Motor Drive Isolation Optional Modifications	Catalog Suffix Code
1a. 115° C Rise	F
1b. 80° C Rise	B
2. Electrostatic Shield	ES
3. Copper Windings	C
4. Wall Mounting Brackets	W
5. Drip Shields/Weather Shields	DS
6. Thermal Switches	TS

(Contact Sales office for List Price)

① Actual taps may vary based on volts/turn ratio.

② For outdoor application. Ventilated transformers requiring drip shields are UL listed for outdoor use. No charge when requested at time of initial project order.

③ Items marked floor and wall can be wall mounted with optional wall bracket identified with "W" suffix on catalog number.

④ Refer selection and application guide for additional information on horsepower, Ampere, KVA ratings and

applications. Standard taps varies with design volts/turn ratio.

⑤ KVA sizes 225 through 660 are available in "RSP" designs as described on page 7-17.

Distribution Dry Type Transformers

Sentron Power Centers

Selection

Economical Space Saving Package

Siemens Sentron Power Center is a pre-wired combination of a primary breaker disconnect, dry type shielded transformer, secondary breaker disconnect and a secondary power panel all in one convenient package.

You save time, space and money by not having to individually assemble, mount and wire these components. Simply add the branch and you're ready to go.

UL-3R Enclosures

All Sentron Power Center enclosures are UL-3R listed for indoor and outdoor use.

Transformer Assembly

Siemens totally encapsulated distribution transformers are designed for general purpose indoor/outdoor operation.

Sentron Power Centers can be installed in a wide variety of atmospheric and environmental conditions. A 180°C, UL recognized insulation system is used.

Sentron Power Center units are electrostatically shielded to provide transient voltage protection at no extra cost. All units have 2-5% FCBN taps.

Panel Assembly

The power panel assembly will accommodate one-inch, 1, 2 or 3-pole, common trip, duplex secondary branch circuit breakers, Type Q and QT as well as ground fault circuit breakers. Per UL and NEC requirements, the Sentron Power Center assembly comes fully equipped with primary and secondary main circuit breakers. Branch circuit breakers can be obtained from our local distributor once you have established your branch circuit requirements. All Sentron Power Centers are UL listed for service entrance.

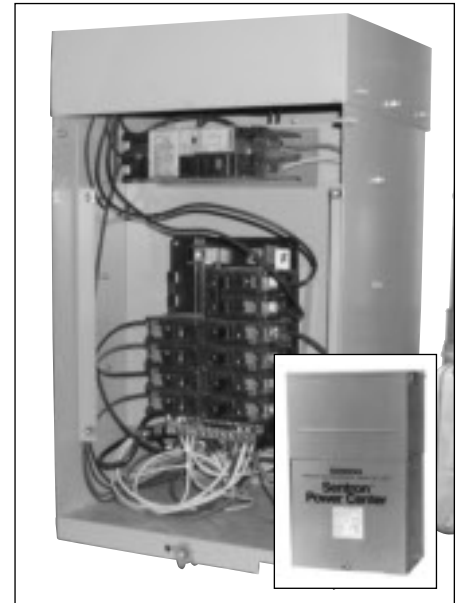

KVA	Catalog Number ^{④⑧⑨}	List Price \$	Maximum Secondary Circuits ^①			Interior Number Reference	Approximate Dimensions (in inches)			Approximate Net Weight (lbs.)
			1" Wide	1/2" Wide	2" Wide		Height	Width	Depth	
			120V (1-Pole)	120V (1-Pole)	240V (2-pole)					

480 Volts Δ Primary, 240/120 Volts Secondary — Single Phase^② — Sentron Power Centers^⑤

5.0	1LPC005	4310.00	8	16	4	I1224L1100CU	32.13	13.25	7.63	120
7.5	1LPC007	5082.00	8	16	4	I1224L1100CU	32.13	15.88	11.00	160
10.0	1LPC010	5520.00	8	16	4	I1224L1100CU	34.38	15.88	11.00	185
15.0	1LPC015	6667.00	12	24	6	I1224L1125CU	34.38	17.13	12.38	240
25.0	1LPC025	8412.00	20	40	10	I2440L1200CU	41.88	17.88	13.50	330

480 Volts Δ Primary, 208Y/120 Volts Secondary — Three Phase^③ — Sentron Power Centers^⑤

9.0	3LPC009	8404.00	12	24	4	I1836L3200CU	33.75	22.13	7.63	255
15.0	3LPC015	12140.00	12	24	4	I1836L3200CU	35.13	22.13	12.38	385
22.5	3LPC022	13486.00	18	36	6	I2442L3200CU	38.25	30.25	13.38	535
30.0	3LPC030	15310.00	24	42	8	I3042L3200CU	43.75	33.00	13.75	680

Circuit Breaker Data for Sentron Power Centers

480 Volts to 240/120 Volts — Single Phase

KVA	480 Volts Primary Breaker ^{①⑥⑦}	240/120 Volts Secondary Main	Maximum Rating of Secondary Breakers
5.0	ED42B025L (25A)	Q225 (25A)	20 Amps
7.5	ED42B025L (25A)	Q240 (40A)	30 Amps
10.0	ED42B035L (35A)	Q250 (50A)	40 Amps
15.0	ED42B050L (50A)	Q270 (70A)	60 Amps
25.0	ED42B090L (90A)	Q2125 (125A)	100 Amps

480 Volts Δ to 280Y/120 Volts — Three Phase

KVA	480 Volts Primary Breaker ^{①⑥⑦}	280Y/120 Volts Secondary Main	Maximum Rating of Secondary Breakers
9.0	ED43B025L (25A)	Q330 (30A)	25 Amps
15.0	ED43B040L (40A)	Q350 (50A)	40 Amps
22.5	ED43B070L (70A)	Q370 (70A)	60 Amps
30.0	ED43B090L (90A)	Q3100 (100A)	80 Amps

① Primary breaker has lineside lug for customer connection.

② Single Phase – 18,000 Amps RMS Symmetrical Interrupting Capacity.

③ Three Phase – 18,000 Amps RMS Symmetrical Interrupting Capacity.

④ Sentron Power Centers are NEMA 3R for outdoor application and may be ordered with "SS" suffix for 304 stainless steel enclosure.

⑤ Secondary branch breakers are not included and must be ordered separately.

⑥ Primary and secondary main breakers are included and are factory installed.

⑦ ED frame breakers furnished are rated 18000 AIC and are sufficient for fault current of transformer. If higher AIC rating is required by spec, the ED can be changed in the field to HED 4 (22000 AIC) or HHED6 (65000 AIC).

⑧ 1LPC005 and 3LPC009 are copper wound.

⑨ Available with Stainless Steel NEMA 3R enclosures by adding catalog number suffix "SS".

Transformers

NEMA TP1 Energy Efficiency Standard

Selection

Single Phase and Three Phase TP1-Energy Efficient Transformers

Most commercial and industrial facilities require several low-voltage transformers to decrease the voltage received from the utility to the voltages used by various loads such as lighting, computers and other electrically operated equipment. Standard transformers convert approximately 95% of the electricity received into usable output voltage. Since these transformers are energized continually, even a small improvement in efficiency can provide significant energy savings. These energy efficient transformers are specifically designed to help save money on utility bills and reduce energy waste.

Depending on the size of the transformer, a "NEMA TP1 compliant" transformer can save \$100-300 each year at an electricity rate of \$0.075 cents per kWh. A typical large commercial facility will have 6-10 low voltage transformers, and thus can save between \$600 and \$3,000 per year.

Basic Design Characteristics

The TP1 designs include the use of higher grade electrical steel and other features designed to lower flux density and reduce

losses especially at average 35% loading where the TP1 measurements apply. To meet TP1 the design engineer must consider both the "I square R" losses and the core or iron losses. Simple de-rating from a higher kVA will not satisfy the TP1 standards as the efficiency level is dependent on the combination of core (no-load) losses and I²R (winding) losses.

The core construction employs the use of high quality non-aging electrical grade grain-oriented silicon steel with high permeability, low hysteresis and low eddy current losses. These characteristics are required to achieve the TP1 efficiency levels. Core laminations must be tightly assembled enabling magnetic flux densities to be kept well below the saturation point.

The core and coil designs must be low loss type with minimum efficiencies per NEMA TP1 when operated at 35% of full load capacity. Efficiency shall be tested in accordance with NEMA TP2 (Standard test method for measuring the energy consumption of distribution transformers). The efficiency levels must meet the following minimums.



TP1- Energy Efficient transformers:

Single Phase		Three Phase	
kVA	Efficiency	kVA	Efficiency
15	97.7%	15	97.0%
25	98.0%	30	97.5%
37.5	98.2%	45	97.7%
50	98.3%	75	98.0%
75	98.5%	112.5	98.2%
100	98.6%	150	98.3%
167	98.7%	225	98.5%
250	98.8%	300	98.6%
333	98.9%	500	98.7%
		750	98.8%

New Super Energy Efficient Transformers:

TP1S, HM1S & HM2S

TP1S transformer designs surpass the NEMA TP1 standards for efficiency. These units are designed not to exceed 115°C temperature rise above a 40°C ambient under full linear load and not to exceed 150°C rise under a non-linear load level of K13 (K20 for HMT units).

Standard features of the TP1S, HM1S, HM2S units include:

- Higher efficiency level with Linear Load Efficiency: 25% less loss than NEMA TP-1 from 35% to 65% load @ 75°C for sizes 15-750KVA
- TP1S units are TP1 Rated efficiency under non-linear loads with a load profile of K13 at 50% loads @ 75°C
- Noise levels are 3 dB lower than NEMA ST-20
- Standard 200% neutral
- K13 rating on nameplate (K20 for HMT units)
- Electrostatic shield
- Ten year pro-rated warranty with standard liability limitations same as Sentron Harmonic Mitigation units



Transformers

Sentron Harmonic Mitigating Transformers (HM1 & HM2)

Selection

Description

The Sentron Harmonic Mitigating Transformers (HMTs) are designed to meet the needs of modern power distribution systems that contain a large percentage of non-linear equipment that produces harmonics. Some examples of this type of equipment are computers, printers, fax machines, scanners, copiers, uninterruptible power supplies, ballast and variable frequency drives (VFD). This type of equipment generates harmonic voltages and currents because they contain AC to DC power conversion rectifiers. Harmonic voltages and currents can cause a variety of problems ranging from poor power factor, voltage distortion, capacitor resonance and motor failures to overloaded transformers and conductors.

The Sentron HMTs are specially designed to operate under high non-linear load conditions and have the additional benefit of improving the overall power system reliability.

Application

One of the most effective ways to eliminate power system harmonics is to use a technique known as "phase shifting." In this method power system harmonics are eliminated by pairing together harmonics that have 180° relative angular displacement, which causes them to cancel one another out. This can be accomplished by a variety of means:

Single Output Harmonic Mitigating Transformer (0° or -30° primary-secondary angular displacement)

- The primary of this transformer has a delta connection and its secondary has a special double winding connection. Although there is only one secondary three phase output, the 3rd, 9th and 15th harmonic currents are prevented from circulating in the primary windings by canceling their magnetic fluxes at low impedance with the double winding secondary, reducing voltage distortions to the loads.
- When two transformers with this type of connection, 0° and -30° displacement, are used in parallel,

the 3rd, 9th and 15th harmonic currents are canceled as previously described, and additionally the 5th and 7th harmonic currents are cancelled in the electrical supply common to both transformers due to their relative 30° phase shift.

- If a single harmonic mitigating transformer (0°) is used in an existing or new system utilizing standard delta-wye transformers (-30°), the 5th and 7th harmonic currents originating from the HMT transformer (0°) will attempt to cancel the 5th and 7th harmonic currents originating from the standard delta-wye transformer (-30°). This reduces the overall 5th and 7th harmonics present in the system, with the actual reduction dependent on the magnitudes of the secondary loads.

Double-Output Harmonic Mitigating Transformer (0° and -30°, -15° and -45°, or +15° and -15° primary-secondary angular displacement)

- The primary of this transformer has a delta connection and its secondary has double-output, special double winding connections with 30° phase shift between outputs. This arrangement cancels the 3rd, 5th, 7th, 9th, and 15th harmonics at very low impedance on the secondary side. This greatly improves voltage distortion for the loads and the primary power factor. The advantage of this arrangement is that the reductions of harmonic currents are achieved with one transformer creating a 12 pulse load.
- If two of these transformers are used, with the primaries of each phase shifted 15° with respect to one another, then cancellation of harmonics up to the 19th are achievable creating a 24 pulse load.

Benefits

Elimination of undesirable harmonics by using the Siemens Sentron HMTs is an effective solution to the power quality problems encountered by today's power system professionals. By treating the harmonics at their source, using advanced technology, installation problems can be avoided and overall system reliability improved. The Sentron HMT product line provides many far

reaching benefits such as lower operating cost, improved operating efficiency, reduced down-time due to outages caused by nuisance tripping, and increased equipment life due to low voltage distortions.

Design and Construction Features

The Sentron Harmonic Mitigating Transformers comply with all applicable ANSI/IEEE standards including C57.12.91, C57.96, C57.110, CSA # C22.2 No. 47 (CUL), UL506, UL1561 as well as NEMA ST-20. The design life is 25 years at 130 degree C rise, 30 years at 115C rise and 40 years for 80C rise models. Approvals and listings include UL, CSA. with CE approval available when requested. The Sentron HMTs have capability up to the load capability up to K-20, which is achieved by harmonic cancellations in the secondary and low flux density design for protection against heat in place of design enlargement protection only. Copper coil windings with full width copper foil electrostatic shield are standard and additional shield options are available for higher noise attenuation requirements. All HMTs have 130C rise with optional 115C and 80C winding rise designs available. All designs include vacuum impregnated polyester resin encapsulation of windings and NEMA 3R enclosures. A neutral sized at 200% of the ampacity of the secondary phase conductors for extra protection against triplens and unbalanced single phase loads. The Sentron HMT designs have TP1 energy efficient rating equal to that of a non K-Factor rated transformer and have the Energy Star emblem displayed. Siemens HMT designs have TP1 efficiency levels at 35% load @ ref temp. 75 degree C and also retain TP1 efficiency levels at 65% load @ reference temperature 85C. A ten-year pro-rated warranty with standard liability limitations applies to all Sentron HMTs.



Transformers

Sentron Harmonic Mitigating Transformers (HM1 & HM2)

Selection

Catalog Number Coding:

Single output (1 secondary) = HM1,
 Double output (2 secondaries) = HM2.
 Phase Shift Options: HM1 followed by > (00) or (30) degree.
 HM2 > (03) for 0 & 30 or (15) for 15 & 45 degree lagging,
 or (PN15) = 15 pos & 15 neg.
 HMT, 480 Volt Primary 120/208 Volt Secondary (3F3) - 130C
 (standard), 115C and 80C Winding Rise displayed on this page.

HMTs are also available with 480 - 277/480 (3F5), 208-120/208 (3B3), 208-277/480 (3B5).

Standard Features Include:

- K-13 Load profile rating.
- TP1 Efficiencies @ 35% and 65% load.
- (C) Copper windings.
- (ES) Electrostatic shield.
- 130 C Winding rise.

KVA	130C (std.) Rise HMT Catalog Number	List Price \$	115C Rise HMT Catalog Number	List Price \$	80C Rise HMT Catalog Number	List Price \$	Secondary Configuration		Enclosure Style	Optional HMT Modifications
							Outputs	Phase Shift		
15	3F3Y015GHM100	Ⓛ	3F3Y015FHM100	Ⓛ	3F3Y015BHM100	Ⓛ	1	Zero Degree	Vented	A,B,C,D,E,F,G,H
15	3F3Y015GHM130	Ⓛ	3F3Y015FHM130	Ⓛ	3F3Y015BHM130	Ⓛ	1	30 Deg Lagging	Vented	A,B,C,D,E,F,G,H
15	3F3Y015GHM203	Ⓛ	3F3Y015FHM203	Ⓛ	3F3Y015BHM203	Ⓛ	2	0 & 30 Lagging	Vented	A,B,C,D,E,F,G,H
15	3F3Y015GHM215	Ⓛ	3F3Y015FHM215	Ⓛ	3F3Y015BHM215	Ⓛ	2	15 & 45 Lagging	Vented	A,B,C,D,E,F,G,H
15	3F3Y015GHM2PN15	Ⓛ	3F3Y015FHM2PN15	Ⓛ	3F3Y015BHM2PN15	Ⓛ	2	15 Pos & 15 Neg	Vented	A,B,C,D,E,F,G,H
30	3F3Y030GHM100	Ⓛ	3F3Y030FHM100	Ⓛ	3F3Y030BHM100	Ⓛ	1	Zero Degree	Vented	A,B,C,D,E,F,G,H
30	3F3Y030GHM130	Ⓛ	3F3Y030FHM130	Ⓛ	3F3Y030BHM130	Ⓛ	1	30 Deg Lagging	Vented	A,B,C,D,E,F,G,H
30	3F3Y030GHM203	Ⓛ	3F3Y030FHM203	Ⓛ	3F3Y030BHM203	Ⓛ	2	0 & 30 Lagging	Vented	A,B,C,D,E,F,G,H
30	3F3Y030GHM215	Ⓛ	3F3Y030FHM215	Ⓛ	3F3Y030BHM215	Ⓛ	2	15 & 45 Lagging	Vented	A,B,C,D,E,F,G,H
30	3F3Y030GHM2PN15	Ⓛ	3F3Y030FHM2PN15	Ⓛ	3F3Y030BHM2PN15	Ⓛ	2	15 Pos & 15 Neg	Vented	A,B,C,D,E,F,G,H
45	3F3Y045GHM100	Ⓛ	3F3Y045FHM100	Ⓛ	3F3Y045BHM100	Ⓛ	1	Zero Degree	Vented	A,B,C,D,E,F,G,H
45	3F3Y045GHM130	Ⓛ	3F3Y045FHM130	Ⓛ	3F3Y045BHM130	Ⓛ	1	30 Deg Lagging	Vented	A,B,C,D,E,F,G,H
45	3F3Y045GHM203	Ⓛ	3F3Y045FHM203	Ⓛ	3F3Y045BHM203	Ⓛ	2	0 & 30 Lagging	Vented	A,B,C,D,E,F,G,H
45	3F3Y045GHM215	Ⓛ	3F3Y045FHM215	Ⓛ	3F3Y045BHM215	Ⓛ	2	15 & 45 Lagging	Vented	A,B,C,D,E,F,G,H
45	3F3Y045GHM2PN15	Ⓛ	3F3Y045FHM2PN15	Ⓛ	3F3Y045BHM2PN15	Ⓛ	2	15 Pos & 15 Neg	Vented	A,B,C,D,E,F,G,H
75	3F3Y075GHM100	Ⓛ	3F3Y075FHM100	Ⓛ	3F3Y075BHM100	Ⓛ	1	Zero Degree	Vented	A,B,C,D,E,F,G,H
75	3F3Y075GHM130	Ⓛ	3F3Y075FHM130	Ⓛ	3F3Y075BHM130	Ⓛ	1	30 Deg Lagging	Vented	A,B,C,D,E,F,G,H
75	3F3Y075GHM203	Ⓛ	3F3Y075FHM203	Ⓛ	3F3Y075BHM203	Ⓛ	2	0 & 30 Lagging	Vented	A,B,C,D,E,F,G,H
75	3F3Y075GHM215	Ⓛ	3F3Y075FHM215	Ⓛ	3F3Y075BHM215	Ⓛ	2	15 & 45 Lagging	Vented	A,B,C,D,E,F,G,H
75	3F3Y075GHM2PN15	Ⓛ	3F3Y075FHM2PN15	Ⓛ	3F3Y075BHM2PN15	Ⓛ	2	15 Pos & 15 Neg	Vented	A,B,C,D,E,F,G,H
112.5	3F3Y112GHM100	Ⓛ	3F3Y112FHM100	Ⓛ	3F3Y112BHM100	Ⓛ	1	Zero Degree	Vented	A,B,C,D,E,F,G,H
112.5	3F3Y112GHM130	Ⓛ	3F3Y112FHM130	Ⓛ	3F3Y112BHM130	Ⓛ	1	30 Deg Lagging	Vented	A,B,C,D,E,F,G,H
112.5	3F3Y112GHM203	Ⓛ	3F3Y112FHM203	Ⓛ	3F3Y112BHM203	Ⓛ	2	0 & 30 Lagging	Vented	A,B,C,D,E,F,G,H
112.5	3F3Y112GHM215	Ⓛ	3F3Y112FHM215	Ⓛ	3F3Y112BHM215	Ⓛ	2	15 & 45 Lagging	Vented	A,B,C,D,E,F,G,H
112.5	3F3Y112GHM2PN15	Ⓛ	3F3Y112FHM2PN15	Ⓛ	3F3Y112BHM2PN15	Ⓛ	2	15 Pos & 15 Neg	Vented	A,B,C,D,E,F,G,H
150	3F3Y150GHM100	Ⓛ	3F3Y150FHM100	Ⓛ	3F3Y150BHM100	Ⓛ	1	Zero Degree	Vented	A,B,C,D,E,F,G,H
150	3F3Y150GHM130	Ⓛ	3F3Y150FHM130	Ⓛ	3F3Y150BHM130	Ⓛ	1	30 Deg Lagging	Vented	A,B,C,D,E,F,G,H
150	3F3Y150GHM203	Ⓛ	3F3Y150FHM203	Ⓛ	3F3Y150BHM203	Ⓛ	2	0 & 30 Lagging	Vented	A,B,C,D,E,F,G,H
150	3F3Y150GHM215	Ⓛ	3F3Y150FHM215	Ⓛ	3F3Y150BHM215	Ⓛ	2	15 & 45 Lagging	Vented	A,B,C,D,E,F,G,H
150	3F3Y150GHM2PN15	Ⓛ	3F3Y150FHM2PN15	Ⓛ	3F3Y150BHM2PN15	Ⓛ	2	15 Pos & 15 Neg	Vented	A,B,C,D,E,F,G,H
225	3F3Y225GHM100	Ⓛ	3F3Y225FHM100	Ⓛ	3F3Y225BHM100	Ⓛ	1	Zero Degree	Vented	A,B,C,D,E,F,G,H
225	3F3Y225GHM130	Ⓛ	3F3Y225FHM130	Ⓛ	3F3Y225BHM130	Ⓛ	1	30 Deg Lagging	Vented	A,B,C,D,E,F,G,H
225	3F3Y225GHM203	Ⓛ	3F3Y225FHM203	Ⓛ	3F3Y225BHM203	Ⓛ	2	0 & 30 Lagging	Vented	A,B,C,D,E,F,G,H
225	3F3Y225GHM215	Ⓛ	3F3Y225FHM215	Ⓛ	3F3Y225BHM215	Ⓛ	2	15 & 45 Lagging	Vented	A,B,C,D,E,F,G,H
225	3F3Y225GHM2PN15	Ⓛ	3F3Y225FHM2PN15	Ⓛ	3F3Y225BHM2PN15	Ⓛ	2	15 Pos & 15 Neg	Vented	A,B,C,D,E,F,G,H
300	3F3Y300GHM100	Ⓛ	3F3Y300FHM100	Ⓛ	3F3Y300BHM100	Ⓛ	1	Zero Degree	Vented	A,B,C,D,E,F,G,H
300	3F3Y300GHM130	Ⓛ	3F3Y300FHM130	Ⓛ	3F3Y300BHM130	Ⓛ	1	30 Deg Lagging	Vented	A,B,C,D,E,F,G,H
300	3F3Y300GHM203	Ⓛ	3F3Y300FHM203	Ⓛ	3F3Y300BHM203	Ⓛ	2	0 & 30 Lagging	Vented	A,B,C,D,E,F,G,H
300	3F3Y300GHM215	Ⓛ	3F3Y300FHM215	Ⓛ	3F3Y300BHM215	Ⓛ	2	15 & 45 Lagging	Vented	A,B,C,D,E,F,G,H
300	3F3Y300GHM2PN15	Ⓛ	3F3Y300FHM2PN15	Ⓛ	3F3Y300BHM2PN15	Ⓛ	2	15 Pos & 15 Neg	Vented	A,B,C,D,E,F,G,H
500	3F3Y500GHM100	Ⓛ	3F3Y500FHM100	Ⓛ	3F3Y500BHM100	Ⓛ	1	Zero Degree	Vented	C,D,E,F,G,H
500	3F3Y500GHM130	Ⓛ	3F3Y500FHM130	Ⓛ	3F3Y500BHM130	Ⓛ	1	30 Deg Lagging	Vented	C,D,E,F,G,H
500	3F3Y500GHM203	Ⓛ	3F3Y500FHM203	Ⓛ	3F3Y500BHM203	Ⓛ	2	0 & 30 Lagging	Vented	C,D,E,F,G,H
500	3F3Y500GHM215	Ⓛ	3F3Y500FHM215	Ⓛ	3F3Y500BHM215	Ⓛ	2	15 & 45 Lagging	Vented	C,D,E,F,G,H
500	3F3Y500GHM2PN15	Ⓛ	3F3Y500FHM2PN15	Ⓛ	3F3Y500BHM2PN15	Ⓛ	2	15 Pos & 15 Neg	Vented	C,D,E,F,G,H

Optional Modifications Table for HMTs		Adder to Base \$	Thermal Sensors 170° C= (TS7), 185° C= (TS8) or 200° C= (TS0)		List Price Adder \$
A	Sound Level LN3= (3dB below NEMA standard)	CSO	H	TS7 = 1 sensor center coil	CSO
B	LN5= (5dB below NEMA standard)	CSO	H	TS72 = 2 sensors center coil	CSO
C	Attenuation—Single shield—60dB Common Mode Std.	CSO	H	TS76 = 6 sensors, (2) on each coil	CSO
D	ES2= Double shield—80dB Common Mode > ES3= Double shield & TVSS—120dB Common >	CSO	H	TS8 = 1 sensor center coil	CSO
	Filtering & Attenuation	CSO	H	TS82 = 2 sensors center coil	CSO
E	TV= Secondary side TVSS (90kA Standard) with common mode noise attenuation	CSO	H	TS86 = 6 sensors, (2) on each coil	CSO
F	TB= Terminal Block	CSO	H	TS0 = 1 sensor center coil	CSO
G	S= Super Energy Efficient (HM1S & HM2S)	CSO	H	TS02 = 2 sensors center coil	CSO
				TS06 = 6 sensors, (2) on each coil	CSO

Ⓛ Contact Sales Office for pricing.

Reduced Size Transformers

Three Phase

Selection

Sentron Reduced Size Plus (RSP)

The "Sentron Reduced Size Plus" is ideal for locations with limited equipment space. This product is specifically designed for easier installation with sufficiently sized bus and all around access for cable entry from bottom, lower back or sides. The rodent proof grillwork at the bottom slides up for insertion of forks or pallet jack for easy positioning. The RSP has 3-phase shunt-trip activated disconnect installed

on the primary side and a safety alarm feature which operates automatically if the coils overheat due to severe load or in case of failure as life expectancy is reached. The "RSP" is a dry type transformer with fan assisted cooling activated by thermal sensors only when needed for peak periods and heavy loading. The RSP system incorporates dry contacts to indicate 3 different temperature levels for customers

wishing to monitor the transformer remotely. Audible noise insulation barriers are factory installed inside of the enclosure for quieter operation for average applications. The "Sentron Reduced Size Plus" is available with copper or aluminum windings in 150C, 115C or 80C rise as well as K-Factor, electrostatic shielding and TP1 efficiency ratings.

Features:

- Approximately 30% smaller and 40% lighter
- Built to NEMA ST-20 standards, IEEE C57 and UL Listed
- 3-phase disconnect switch factory installed on primary. Protection from overheating with shunt trip device.
- Easy connection to LV lug landing pads
- Lugs provided on disconnect for HV connections to disconnect
- Cable entrance from lower back, sides or bottom
- Quiet operation for average applications; 2 dB below NEMA std.
- Thermal switches activate (Fans) @125°C, (Alarm) @190°C and (Disconnect) @200°C.
- Greater efficiency than standard models
- Dry contacts for remote monitoring connections
- Same distance to wall as standard units
- Front access for easy maintenance
- Enclosure is rodent proof by design
- Audible safety alarm to signal overheating
- NEMA 3R with weather shields added
- Energy efficient NEMA-TP1 designs

Sizes Available:

150-1000 KVA.

SMALLER
LIGHTER
QUIETER
ENERGY EFFICIENT



Warehouse Stock Transformers

Type QST (Standard Units)

Selection

KVA	Catalog Number	List Price \$	Taps ^①	Temperature Rise	Insulation	Mounting Type ^②	Drip Shield Required ^③	Enclosure Style ^④
-----	----------------	---------------	-------------------	------------------	------------	----------------------------	-----------------------------------	------------------------------

Single Phase

240 × 480 Volts Primary, 120/240 Volts Secondary

.05	1D1N555QST	98.00	N	115° C	180° C	Wall	None	Encapsulated
.075	1D1N775QST	114.00	N	115° C	180° C	Wall	None	Encapsulated
.10	1D1N110QST	114.00	N	115° C	180° C	Wall	None	Encapsulated
.15	1D1N115QST	163.00	N	115° C	180° C	Wall	None	Encapsulated
.25	1D1N205QST	164.00	N	115° C	180° C	Wall	None	Encapsulated
.50	1D1N505QST	255.00	N	115° C	180° C	Wall	None	Encapsulated
.75	1D1N705QST	381.00	N	115° C	180° C	Wall	None	Encapsulated
1.0	1D1N001QST	380.00	N	115° C	180° C	Wall	None	Encapsulated
1.5	1D1N105QST	552.00	N	115° C	180° C	Wall	None	Encapsulated
2.0	1D1N002QST	631.00	N	115° C	180° C	Wall	None	Encapsulated
3.0	1D1N003QST	769.00	N	115° C	180° C	Wall	None	Encapsulated
5.0	1D1N005QST	968.00	N	115° C	180° C	Wall	None	Encapsulated
7.5	1D1N007QST	1405.00	N	115° C	180° C	Wall	None	Encapsulated
10	1D1N010QST	1603.00	N	115° C	180° C	Wall	None	Encapsulated
15	1D1N015QST	1868.00	N	115° C	180° C	Wall	None	Encapsulated
25	1D1Y025TP1QST	5283.00	Y	150° C	220° C	Floor & Wall	DSK11Q	Ventilated
37.5	1D1Y037TP1QST	6720.00	Y	150° C	220° C	Floor & Wall	DSK12Q	Ventilated
50	1D1Y050TP1QST	7737.00	Y	150° C	220° C	Floor & Wall	DSK12Q	Ventilated
75	1D1Y075TP1QST	10254.00	Y	150° C	220° C	Floor & Wall	DSK12Q	Ventilated
100	1D1Y100TP1QST	21106.00	Y	150° C	220° C	Floor	DSK15Q	Ventilated
167	1D1Y167TP1QST	32804.00	Y	150° C	220° C	Floor	DSK15Q	Ventilated

Three Phase

480 Volts Δ Primary, 208Y/120 Volts Secondary

3	3F3R003QST	1807.00	R	115° C	180° C	Wall	None	Encapsulated
6	3F3R006QST	1899.00	R	115° C	180° C	Wall	None	Encapsulated
9	3F3R009QST	2735.00	R	115° C	180° C	Wall	None	Encapsulated
15	3F3Y015TP1QST	4246.00	Y	150° C	220° C	Floor & Wall	DSK31Q	Ventilated
30	3F3Y030TP1QST	6468.00	Y	150° C	220° C	Floor & Wall	DSK11Q	Ventilated
45	3F3Y045TP1QST	6494.00	Y	150° C	220° C	Floor & Wall	DSK11Q	Ventilated
75	3F3Y075TP1QST	9244.00	Y	150° C	220° C	Floor & Wall	DSK12Q	Ventilated
112.5	3F3Y112TP1QST	11607.00	Y	150° C	220° C	Floor	DSK12Q	Ventilated
150	3F3Y150TP1QST	15472.00	Y	150° C	220° C	Floor	DSK34Q	Ventilated
225	3F3Y225RTP1QST	24774.00	Y	150° C	220° C	Floor	DSK15Q	Ventilated
300	3F3Y300RTP1QST	34349.00	Y	150° C	220° C	Floor	DSK36Q	Ventilated
500	3F3Y500RTP1QST	54933.00	Y	150° C	220° C	Floor	DSK37Q	Ventilated

Three Phase

480 Volts Δ Primary, 240 Volts Δ Secondary With 120 Volt Tap On B Phase^⑤

15	3F1Y015TP1QST	4204.00	Y	150° C	220° C	Floor & Wall	DSK31Q	Ventilated
30	3F1Y030TP1QST	6562.00	Y	150° C	220° C	Floor & Wall	DSK11Q	Ventilated
45	3F1Y045TP1QST	6648.00	Y	150° C	220° C	Floor & Wall	DSK11Q	Ventilated
75	3F1Y075TP1QST	9606.00	Y	150° C	220° C	Floor & Wall	DSK12Q	Ventilated
112.5	3F1Y112TP1QST	13152.00	Y	150° C	220° C	Floor	DSK12Q	Ventilated
150	3F1Y150TP1QST	15852.00	Y	150° C	220° C	Floor	DSK34Q	Ventilated

Taps

Description	Designation
4-3% (2 FCAN, 2 FCBN)	J
2-3.5% (1 FCAN, 1 FCBN)	K
3-5% (1 FCAN, 2 FCBN)	M
None	N
2-5% FCBN	R
2-5% (1 FCAN, 1 FCBN)	S
4-2.5% (2 FCAN, 2 FCBN)	T
2-2.5% FCBN	U
4-2.5% FCBN	X
6-2.5% (2 FCAN, 4 FCBN)	Y

① Actual taps are shown for warehouse stock transformers.

② Wall designations for units having standard features.

③ For outdoor application. Ventilated transformers requiring drip shields are UL listed for outdoor use.

④ Encapsulated transformers are UL listed for indoor/outdoor use.

⑤ Reduced capacity 1-phase tap—5% of rated KVA (2.5% on each side of lighting tap).

☐ = Warehouse Stock

Warehouse Stock Transformers

Type QST and Buck-Boost Transformers

Selection

Encapsulated, Indoor/Outdoor Enclosure, 115° C Rise

120 × 240 Volts — 12/24 Volts,
60 Hz, No Taps, Wall Mounted

Catalog Number	KVA	List Price \$
050BB1224Q	.050	241.00
100BB1224Q	.100	278.00
150BB1224Q	.150	334.00
205BB1224Q	.250	391.00
505BB1224Q	.500	539.00
705BB1224Q	.750	688.00
1BB1224Q	1.00	890.00
105BB1224Q	1.50	1077.00
2BB1224Q	2.00	1318.00
3BB1224Q	3.00	1763.00
5BB1224Q	5.00	2525.00

120 × 240 Volts — 16/32 Volts,
60 Hz, No Taps, Wall Mounted

Catalog Number	KVA	List Price \$
050BB1632Q	.050	241.00
100BB1632Q	.100	278.00
150BB1632Q	.150	334.00
205BB1632Q	.250	391.00
505BB1632Q	.500	539.00
705BB1632Q	.750	688.00
1BB1632Q	1.00	890.00
105BB1632Q	1.50	1077.00
2BB1632Q	2.00	1318.00
3BB1632Q	3.00	1763.00
5BB1632Q	5.00	2525.00

240 × 480 Volts — 24/48 Volts,
60 Hz, No Taps, Wall Mounted

Catalog Number	KVA	List Price \$
050BB2448Q	.050	278.00
100BB2448Q	.100	334.00
150BB2448Q	.150	372.00
205BB2448Q	.250	447.00
505BB2448Q	.500	613.00
705BB2448Q	.750	780.00
1BB2448Q	1.00	983.00
105BB2448Q	1.50	1188.00
2BB2448Q	2.00	1448.00
3BB2448Q	3.00	1763.00
5BB2448Q	5.00	3694.00

Accessories

Dripshield/Weathershield Kits for Type QST Ventilated Transformers^①

Catalog Number	Single Phase 150°C Rise & TP1 KVA Sizes	Three Phase 150°C Rise & TP1 KVA Sizes	Single Phase 115°C Rise & TP1 KVA Sizes	Three Phase 115°C Rise & TP1 KVA Sizes	Single Phase 80°C Rise & TP1 KVA Sizes	Three Phase 80°C Rise & TP1 KVA Sizes	Nameplate Ref. #
DSK11Q	25	30, 45	—	30	—	15, 30	4317G05
DSK12Q	37.5, 50, 75	75, 112.5	25, 37.5, 50	45, 75	25, 37.5	45, 75	4317G06
DSK34Q	—	150	—	112.5	—	—	4317G07
DSK15Q	100, 167	225	75, 100	150	50, 75, 100	112.5, 150	4317G08
DSK36Q	—	300	—	225	—	—	4317G09
DSK37Q	—	500	—	300	—	—	4317G10
DSK31Q	—	15	—	15	—	—	4317G11
DSK38Q	—	750, 1000	—	500, 750	—	500	4317G67

Wall Mounting Brackets for Type QST Ventilated Transformers

Catalog Number	Single Phase 150°C Rise & TP1 KVA Sizes	Three Phase 150°C Rise & TP1 KVA Sizes	Single Phase 115°C Rise & TP1 KVA Sizes	Three Phase 115°C Rise & TP1 KVA Sizes	Single Phase 80°C Rise & TP1 KVA Sizes	Three Phase 80°C Rise & TP1 KVA Sizes
WMB42Q	25	15, 30, 45	—	15, 30	—	15, 30
WMB43Q	37.5, 50	75	25, 37.5	45	25	45

Terminal Lug Kits For Ventilated Transformers

Catalog Number	Single Phase KVA Sizes	Three Phase KVA Sizes	List Price \$	Terminal Lug ^③		Cable Range	Terminal Lug ^③		Cable Range	Hardware Included	
				Qty. ^④	Lug No.		Qty. ^④	Lug No.		Qty.	Bolt Size
TLK31Q	—	15	65.00	7	KA25U/TA0	14awg-1/0mcm	n/a			7	1/4" x 1"
TLK32Q	—	30, 45	141.00	7	KA29U/TA250	6awg-250mcm	n/a			7	5/16" x 1 1/2"
TLK11Q	25, 37.5	—	127.00	8	KA29U/TA250	6awg-250mcm	n/a			8	5/16" x 1 1/2"
TLK13Q	75	—	279.00	12	KA29U/TA250	6awg-250mcm	n/a			12	5/16" x 1 1/2"
TLK33Q	—	75	243.00	3	KA29U/TA250	6awg-250mcm	8	KA31U/TA350	6awg-350mcm	3, 8	(3) 5/16" x 1 1/2" (8) 3/8" x 1 1/2"
TLK12Q	50	—	191.00	4	KA29U/TA250	6awg-250mcm	4	KA31U/TA350	6awg-350mcm	8	3/8" x 1 1/2"
TLK34Q	—	112.5	243.00	11	KA31U/TA350	6awg-350mcm	n/a			11	3/8" x 1 1/2"
TLK36Q	—	225	459.00	22	KA31U/TA350	6awg-350mcm	n/a			22	3/8" x 1 1/2"
TLK35Q	—	150	396.00	3	KA31U/TA350	6awg-350mcm	8	KA34U/TA500	4awg-500mcm	11	3/8" x 1 1/2"
TLK37Q	—	300	638.00	6	KA31U/TA350	6awg-350mcm	16	KA34U/TA500	4awg-500mcm	22	3/8" x 1 1/2"
TLK15Q	167	—	562.00	8	KA31U/TA350	6awg-350mcm	12	KA34U/TA500	4awg-500mcm	20	3/8" x 1 1/2"
TLK38Q	—	500	1150.00	9	KA31U/TA350	6awg-350mcm	24	KA34U/TA500	4awg-500mcm	33	3/8" x 1 1/2"
TLK14Q	100	—	279.00	12	KA31U/TA350	6awg-350mcm	n/a			12	3/8" x 1 1/2"
TLK39Q	—	750	1430.00	12	KA31U/TA350	6awg-350mcm	28	KA34U/TA500	4awg-500mcm	40	3/8" x 1 1/2"

① These accessories fit only warehouse stock transformers with QST Catalog Suffix.

② UL Listed for indoor and outdoor use with dripshield installed.

③ May be used on "QST" suffix units and "non QST" suffix transformers. Terminal lugs are screw type, lug connectors suitable for both copper and aluminum cable. TA lugs are single barrel, AU lugs are double barrel. Each barrel is suitable for cable range shown. Lugs are rated 90° C

④ Lug kit contains quantity required for each transformer.

Warehouse Stock Transformers

Warehouse Stock

Selection



Application

The Buck-Boost Transformer has four separate windings, two-windings in the primary and two-windings in the secondary. The unit is designed for use as an insulating transformer or as an autotransformer. As an autotransformer the unit can be connected to Buck (decrease) or Boost (increase) a supply voltage. When connected in either the Buck or Boost mode, the unit is no longer an insulating transformer but is an autotransformer. Units are designed for 60Hz applications.

Autotransformers are more economical and physically smaller than equivalent two-winding transformers and are designed to carry the same function as two-winding transformers, with the exception of isolating two circuits. Since autotransformers may transmit line disturbances directly, they may be prohibited in some areas by local building codes. Before applying them, care should be taken to assure that they are acceptable according to local code.

NOTE: Autotransformers are not used in closed delta connections as they introduce into the circuit a phase shift which makes them uneconomical.

As insulating transformers these units can accommodate a high voltage of 120, 240 or 480 volts. For units with two 12 volt secondaries, two 16 volt secondaries, or two 24 volt secondaries, the output can be wired for either secondary voltage, or for 3-wire secondary. The unit is rated (KVA) as any conventional transformer.

Operation

Electrical and electronic equipment is designed to operate on a standard supply voltage. When the supply voltage is constantly too high or too low, (usually greater than $\pm 5\%$), the equipment fails to operate at maximum efficiency. A Buck-Boost transformer is a simple and economical

means of correcting this off-standard voltage up to $\pm 20\%$. A Buck-Boost transformer will NOT, however, stabilize a fluctuating voltage. Buck-Boost transformers are suitable for use in a three phase autotransformer bank in either direction to supply 3-wire loads. They are also suitable for use in a three phase autotransformer bank which provides a neutral return for unbalanced current. They are NOT suitable for use in a three phase autotransformer bank to supply a 4-wire unbalanced load when the source is a 3-wire circuit.

Construction

Buck-Boost Transformers are contained within a NEMA 3R, non-ventilated weather-proof enclosure. Wiring compartments are located at the bottom. Core and coil assemblies are encapsulated. Insulation system temperature is 180°C and the winding temperature rise is 115°C . Coils are copper wound through 3 kva.

How To Select The Proper Transformer

To select the proper Transformer for Buck-Boost applications, determine:

1. Input line voltage — The voltage that you want to buck (decrease) or boost (increase). This can be found by measuring the supply line voltage with a voltmeter.
2. Load voltage — The voltage at which your equipment is designed to operate. This is listed on the nameplate of the load equipment.
3. Load KVA or Load Amps — You do not need to know both — one or the other is sufficient for selection purposes. This information usually can be found on the nameplate of the equipment that you want to operate.

4. Number of phases — Single or three phase line and load should match because a transformer is not capable of converting single to three phase. It is however a common application to make a single phase transformer connection from a three phase supply by use of one leg of the three phase supply circuit. Care must always be taken not to overload the leg of the three phase supply. This is particularly true in a Buck-Boost application because the supply must provide for the load KVA, not just the nameplate rating of the Buck-Boost transformer.
5. Frequency — The supply line frequency must be the same as the frequency of the equipment to be operated — either 50 or 60 cycles.

How To Use Selection Charts

1. Choose the selection table with the correct number of phases for single or three phase applications.
2. Line/Load voltage combinations are listed across the top of the selection table. Select a line/load voltage combination which comes closest to matching your applications.
3. Follow the selected column down until you find either the KVA or load amps of your application. If you do not find the exact value, go on the next highest rating.
4. Now follow across the table to the far left-hand side to find the catalog number and the KVA of the transformer you need.
5. Follow the column of your line/load voltage to the bottom to find the connection diagram for this application.
NOTE: Connection diagrams show low voltage and high voltage connection terminals. Either can be input or output depending on Buck or Boost application.
6. In the case of three phase loads either two or three single phase transformers are required as indicated in the "quantity required" line at the bottom of the table. The selection is dependent on whether a Wye connected bank of three transformers with a neutral is required or whether an open Delta connected bank of two transformers for a Delta connected load will be suitable.
7. For line/load voltage not listed on the selection tables, use the pair listed on the table that is slightly above your application for reference. Then apply the first formula at the bottom of the table to determine "new" output voltage. The new KVA rating can be found using the second formula.

Warehouse Stock Transformers

Buck-Boost

Selection

120 × 240 Volts Primary — 12/24 Volts Secondary, 60 Hz, No Taps, Wall Mounted

Single Phase — Table 1			Boosting								Bucking					
Catalog Number	Line Voltage (Available)		96	100	105	109	189	208	215	220	125	132	229	245	250	252
Insulating Transformer Rating	Load Voltage (Output)		115	120	115	120	208	229	237	242	114	120	208	222	227	240
050BB1224Q .050 KVA	KVA		.24	.25	.50	.50	.43	.48	.49	.50	.52	.55	.48	.51	.52	1.05
	Load Amps		2.08	2.08	4.17	4.17	2.08	2.08	2.08	2.08	4.59	4.59	2.29	2.29	2.29	4.38
100BB1224Q .100 KVA	KVA		.48	.50	.96	1.00	.87	.95	.99	1.01	1.04	1.10	.95	1.02	1.04	2.10
	Load Amps		4.17	4.17	8.33	8.33	4.17	4.17	4.17	4.17	9.16	9.16	4.58	4.58	4.58	8.75
150BB1224Q .150 KVA	KVA		.72	.75	1.44	1.50	1.30	1.43	1.48	1.51	1.55	1.65	1.43	1.53	1.56	3.15
	Load Amps		6.25	6.25	12.50	12.50	6.25	6.25	6.25	6.25	13.75	13.75	6.88	6.88	6.88	13.13
205BB1224Q .250 KVA	KVA		1.19	1.25	2.40	2.50	2.17	2.38	2.47	2.52	2.60	2.75	2.38	2.54	2.60	5.25
	Load Amps		10.42	10.42	20.83	20.83	10.42	10.42	10.42	10.42	22.92	22.92	11.46	11.46	11.46	21.88
505BB1224Q .500 KVA	KVA		2.37	2.50	4.80	5.00	4.33	4.77	4.94	5.04	5.18	5.50	4.77	5.09	5.20	10.50
	Load Amps		20.83	20.83	41.67	41.67	20.83	20.83	20.83	20.83	45.83	45.83	22.92	22.92	22.92	43.75
705BB1224Q .750 KVA	KVA		3.56	3.75	7.19	7.50	6.50	7.15	7.41	7.56	7.77	8.25	7.15	7.63	7.80	15.75
	Load Amps		31.25	31.25	62.50	62.50	31.25	31.25	31.25	31.25	68.75	68.75	34.38	34.38	34.38	65.63
1BB1224Q 1.00 KVA	KVA		4.75	5.00	9.58	10.00	8.67	9.53	9.88	10.08	10.36	11.00	9.53	10.17	10.40	21.00
	Load Amps		41.67	41.67	83.33	83.33	41.67	41.67	41.67	41.67	91.66	91.66	45.83	45.83	45.83	87.50
105BB1224Q 1.50 KVA	KVA		7.13	7.50	14.38	15.00	13.00	14.30	14.81	15.13	15.54	16.50	14.30	15.26	15.61	31.50
	Load Amps		62.50	62.50	125.00	125.00	62.50	62.50	62.50	62.50	137.50	137.50	68.75	68.75	68.75	131.25
2BB1224Q 2.00 KVA	KVA		9.50	10.00	19.17	20.00	17.33	19.07	19.75	20.17	20.72	22.00	19.07	20.35	20.81	42.00
	Load Amps		83.33	83.33	166.66	166.66	83.33	83.33	83.33	83.33	183.33	183.33	91.66	91.66	91.66	175.00
3BB1224Q 3.00 KVA	KVA		14.25	15.00	28.75	30.00	26.00	28.60	29.63	30.25	31.08	33.00	28.60	30.53	31.21	63.00
	Load Amps		125.00	125.00	250.00	250.00	125.00	125.00	125.00	125.00	275.00	275.00	137.50	137.50	137.50	262.50
5BB1224Q 5.00 KVA	KVA		23.75	25.00	47.92	50.00	43.33	47.67	49.37	50.42	51.79	55.00	47.67	50.88	52.02	105.00
	Load Amps		208.33	208.33	416.66	416.66	208.33	208.33	208.33	208.33	458.33	458.33	229.17	229.17	229.17	437.50
Connection Diagram (pg. 7-24)			B	B	B	A	A	D	D	D	D	A	A	D	D	C

Three Phase — Table 2			Boosting								Bucking					
Catalog Number	Line Voltage (Available)		189Y/ 109	195Y/ 113	200Y/ 115	208Y/ 120	416Y/ 240	416Y/ 240	189	208	220	218	229	250	255	264
Insulating Transformer Rating	Load Voltage (Output)		208Y/ 120	234Y/ 135	240Y/ 139	229Y/ 132	458Y/ 264	437Y/ 252	208	229	242	208	208	227	232	240
050BB1224Q .050 KVA	KVA		1.50	.84	.86	1.65	1.65	3.15	.75	.83	.87	1.58	.83	.90	.92	.95
	Load Amps		4.17	2.08	2.08	4.17	2.08	4.17	2.08	2.08	2.08	4.39	2.29	2.29	2.29	2.29
100BB1224Q .100 KVA	KVA		3.00	1.69	1.73	3.30	3.30	6.29	1.50	1.65	1.75	3.15	1.65	1.80	1.84	1.90
	Load Amps		8.33	4.17	4.17	8.33	4.17	8.33	4.17	4.17	4.17	8.75	4.58	4.58	4.58	4.58
150BB1224Q .150 KVA	KVA		4.50	2.54	2.60	4.96	4.96	9.44	2.26	2.48	2.62	4.73	2.48	2.71	2.76	2.86
	Load Amps		12.50	6.25	6.25	12.50	6.25	12.50	6.25	6.25	6.25	13.13	6.88	6.88	6.88	6.88
205BB1224Q .250 KVA	KVA		7.50	4.22	4.33	8.30	8.25	15.75	3.75	4.13	4.37	7.88	4.13	4.50	4.61	4.76
	Load Amps		20.83	10.42	10.42	20.83	10.42	20.83	10.42	10.42	10.42	21.88	11.46	11.46	11.46	11.46
505BB1224Q .500 KVA	KVA		15.01	8.44	8.66	16.60	16.50	31.50	7.50	8.26	8.73	15.76	8.26	9.01	9.21	9.53
	Load Amps		41.67	20.83	20.83	41.67	20.83	41.67	20.83	20.83	20.83	43.75	22.92	22.92	22.92	22.92
705BB1224Q .750 KVA	KVA		22.52	12.67	12.99	24.90	24.75	47.25	11.26	12.39	13.10	23.64	12.39	13.52	13.82	14.29
	Load Amps		62.50	31.25	31.25	62.50	31.25	62.50	31.25	31.25	31.25	65.63	34.38	34.38	34.38	34.38
1BB1224Q 1.00 KVA	KVA		30.02	16.89	17.32	33.20	33.00	63.00	15.01	16.51	17.47	31.52	16.51	18.02	18.42	19.05
	Load Amps		83.33	41.67	41.67	83.33	41.67	83.33	41.67	41.67	41.67	87.50	45.83	45.83	45.83	45.53
105BB1224Q 1.50 KVA	KVA		45.03	25.33	25.98	49.80	49.50	94.50	22.52	24.77	26.20	47.28	24.77	27.03	27.63	28.53
	Load Amps		125.00	62.50	62.50	125.00	62.50	125.00	62.50	62.50	62.50	131.25	68.75	68.75	68.75	68.75
2BB1224Q 2.00 KVA	KVA		60.06	33.77	34.64	66.40	66.00	126.00	30.02	33.03	34.93	63.05	33.03	36.04	36.84	38.11
	Load Amps		166.67	83.33	83.33	166.67	83.33	166.66	83.33	83.33	83.33	175.00	91.67	91.67	91.67	91.67
3BB1224Q 3.00 KVA	KVA		90.07	50.66	51.96	99.59	99.00	189.00	45.03	49.54	52.39	94.57	49.54	54.06	55.25	57.16
	Load Amps		250.00	125.00	125.00	250.00	125.00	250.00	125.00	125.00	125.00	262.50	137.50	137.50	137.50	137.50
5BB1224Q 5.00 KVA	KVA		150.11	84.44	86.60	165.99	165.00	318.00	75.05	82.56	87.32	157.62	82.56	90.10	92.09	95.26
	Load Amps		416.67	208.33	208.33	416.67	208.33	416.66	208.33	208.33	208.33	437.50	229.17	229.17	229.17	229.17
Quantity Required			3	3	3	3	3	3	2	2	2	2	2	2	2	2
Connection Diagram (pg. 7-24)			F	E	E	F	J	K	G	G	G	H	G	G	G	G

☐ = Warehouse Stock

• Output voltage for lower input voltage can be found by:
 $\frac{\text{Rated Output Voltage}}{\text{Rated Input Voltage}} \times \text{Input Actual Voltage} = \text{Output New Voltage}$

• Output KVA available at reduced input voltage can be found by:
 $\frac{\text{Actual Input Voltage}}{\text{Rated Input Voltage}} \times \text{Output KVA} = \text{New KVA Rating}$

• Inputs and outputs may be reversed without affecting KVA capacity. See note on page 7-24

Warehouse Stock Transformers

Buck-Boost

Selection

120 × 240 Volts Primary — 16/32 Volts Secondary, 60 Hz, No Taps, Wall Mounted

Single Phase — Table 3			Boosting							Bucking						
Catalog Number	Line Voltage (Available)		95	100	105	208	215	215	220	225	135	240	240	245	250	255
Insulating Transformer Rating	Load Voltage (Output)		120	113	119	236	244	229	235	240	120	212	225	230	234	239
050BB1632Q .050 KVA	KVA		.19	.36	.37	.37	.38	.72	.73	.73	.42	.37	.75	.77	.78	.80
	Load Amps		1.56	3.12	3.12	1.56	1.56	3.12	3.12	3.12	3.54	1.77	3.33	3.33	3.33	3.33
100BB1632Q .100 KVA	KVA		.38	.72	.74	.74	.76	1.44	1.46	1.50	.84	.74	1.50	1.54	1.56	1.60
	Load Amps		3.13	6.25	6.25	3.13	3.13	6.25	6.25	6.25	7.09	3.54	6.66	6.66	6.66	6.66
150BB1632Q .150 KVA	KVA		.56	1.06	1.12	1.12	1.14	2.16	2.20	2.26	1.26	1.10	2.26	2.30	2.34	2.40
	Load Amps		4.69	9.38	9.38	4.69	4.69	9.38	9.38	9.38	10.64	5.30	10.02	10.02	10.02	10.02
205BB1632Q .250 KVA	KVA		.94	1.78	1.86	1.88	1.91	3.59	3.67	3.75	2.11	1.84	3.75	3.83	3.90	3.98
	Load Amps		7.81	15.63	15.63	7.81	7.81	15.63	15.63	15.63	17.71	8.85	16.67	16.67	16.67	16.67
505BB1632Q .500 KVA	KVA		1.88	3.56	3.72	3.75	3.81	7.19	7.34	7.50	4.21	3.68	7.50	7.67	7.80	7.97
	Load Amps		15.63	31.25	31.25	15.63	15.63	31.25	31.25	31.25	35.42	17.71	33.33	33.33	33.33	33.33
705BB1632Q .750 KVA	KVA		2.81	5.34	5.58	5.63	5.72	10.78	11.02	11.25	6.32	5.53	11.25	11.50	11.70	11.95
	Load Amps		23.44	46.88	46.88	23.44	23.44	46.88	46.88	46.88	53.13	26.56	50.00	50.00	50.00	50.00
1BB1632Q 1.00 KVA	KVA		3.75	7.13	7.44	7.50	7.63	14.38	14.69	15.00	8.43	7.37	15.00	15.33	15.60	15.93
	Load Amps		31.25	62.50	62.50	31.25	31.25	62.50	62.50	62.50	70.83	35.42	66.67	66.67	66.67	66.67
105BB1632Q 1.50 KVA	KVA		5.63	10.69	11.16	11.25	11.44	21.56	22.03	22.50	12.64	11.05	22.50	23.00	23.40	23.90
	Load Amps		43.90	93.80	93.80	46.90	46.90	93.80	93.80	93.80	106.30	53.10	100.00	100.00	100.00	100.00
2BB1632Q 2.00 KVA	KVA		7.50	14.25	14.88	15.00	15.25	28.75	29.38	30.00	16.86	14.73	30.00	30.67	31.20	31.87
	Load Amps		62.50	125.00	125.00	62.50	62.50	125.00	125.00	125.00	141.70	70.80	133.30	133.30	133.30	133.30
3BB1632Q 3.00 KVA	KVA		11.25	21.38	22.31	22.50	22.88	43.13	44.06	45.00	25.29	22.10	45.00	46.00	46.80	47.80
	Load Amps		93.80	187.50	187.50	93.80	93.80	187.50	187.50	187.50	212.50	106.30	200.00	200.00	200.00	200.00
5BB1632Q 5.00 KVA	KVA		18.75	35.63	37.19	37.50	38.13	71.88	73.44	75.00	42.15	36.83	75.00	76.67	78.00	79.67
	Load Amps		156.30	312.50	312.50	156.30	156.30	312.50	312.50	312.50	354.20	177.10	333.30	333.30	333.30	333.30
Connection Diagram (pg. 7-24)			B	A	A	D	D	C	C	C	A	D	C	C	C	C

Three Phase — Table 4			Boosting					Bucking					
Catalog Number	Line Voltage (Available)		183Y/ 106	208Y/ 120	195	208	225	240	245	250	256	265	272
Insulating Transformer Rating	Load Voltage (Output)		208Y/ 120	236Y/ 136	208	236	240	208	230	234	240	234	240
050BB1632Q .050 KVA	KVA		1.13	1.28	1.13	.62	1.30	.56	1.33	1.35	1.39	.72	.74
	Load Amps		3.13	3.13	3.13	1.56	3.13	1.56	3.34	3.34	3.34	1.77	1.77
100BB1632Q .100 KVA	KVA		2.25	2.55	2.25	1.30	2.60	1.13	2.66	2.70	2.77	1.44	1.48
	Load Amps		6.25	6.25	6.25	3.13	6.25	3.13	6.67	6.67	6.67	3.55	3.55
150BB1632Q .150 KVA	KVA		3.38	3.83	3.38	1.95	3.90	1.69	3.98	4.05	4.16	2.15	2.21
	Load Amps		9.38	9.38	9.38	4.69	9.38	4.69	10.00	10.00	10.00	5.31	5.31
205BB1632Q .250 KVA	KVA		5.63	6.39	5.63	3.17	6.50	2.81	6.64	6.76	6.93	3.59	3.68
	Load Amps		15.63	15.63	15.63	7.81	15.63	7.81	16.67	16.67	16.67	8.85	8.85
505BB1632Q .500 KVA	KVA		11.26	12.77	11.26	6.33	12.99	5.63	13.28	13.50	13.86	7.17	7.36
	Load Amps		31.25	31.26	31.25	15.63	31.25	15.63	33.33	33.33	33.33	17.69	17.71
705BB1632Q .750 KVA	KVA		16.89	19.16	16.89	9.50	19.49	8.44	19.92	20.26	20.78	10.76	11.04
	Load Amps		46.88	46.88	46.88	23.44	46.88	23.44	50.00	50.00	50.00	26.54	26.56
1BB1632Q 1.00 KVA	KVA		22.52	25.55	22.52	12.67	25.98	11.26	26.56	27.02	27.71	14.34	14.72
	Load Amps		62.50	62.50	62.50	31.25	62.50	31.25	66.67	66.67	66.67	35.39	35.42
105BB1632Q 1.50 KVA	KVA		33.77	38.32	33.77	19.00	38.97	16.89	39.84	40.53	41.57	21.52	22.08
	Load Amps		93.75	93.75	93.75	46.88	93.75	46.88	100.00	100.00	100.00	53.08	53.13
2BB1632Q 2.00 KVA	KVA		45.03	51.10	46.03	25.33	51.96	22.52	53.11	54.04	55.43	28.69	29.44
	Load Amps		125.00	125.00	125.00	62.50	125.00	62.50	133.33	133.33	133.33	70.78	70.83
3BB1632Q 3.00 KVA	KVA		67.55	76.64	67.55	38.00	77.94	33.77	79.67	81.06	83.14	43.03	44.17
	Load Amps		187.50	187.50	187.50	93.75	187.50	93.75	200.00	200.00	200.00	106.17	106.25
5BB1632Q 5.00 KVA	KVA		112.58	127.74	112.58	63.33	129.90	56.29	132.79	135.09	138.56	71.72	73.61
	Load Amps		312.50	312.50	312.50	156.25	312.50	156.25	333.33	333.33	333.33	176.95	177.08
Quantity Required			3	3	2	2	2	2	2	2	2	2	2
Connection Diagram (pg. 7-24)			F	F	H	G	H	L	H	H	H	G	G

☐ = Warehouse Stock

• Output KVA available at reduced input voltage can be found by:
 $\frac{\text{Actual Input Voltage}}{\text{Rated Input Voltage}} \times \text{Output KVA} = \text{New KVA Rating}$

• Output KVA available at reduced input voltage can be found by:
 $\frac{\text{Actual Input Voltage}}{\text{Rated Input Voltage}} \times \text{Output KVA} = \text{New KVA Rating}$

Warehouse Stock Transformers

Buck-Boost

Selection

240 × 480 Volts Primary — 24/48 Volts Secondary, 60 Hz, No Taps, Wall Mounted

Single Phase — Table 5			Boosting									Bucking				
Catalog Number	Line Voltage (Available)		230	380	416	425	430	435	440	450	450	460	277	480	480	504
Insulating Transformer Rating	Load Voltage (Output)		276	418	458	468	473	457	462	495	472	483	231	436	457	480
050BB2448Q .050 KVA	KVA		.29	.44	.48	.49	.49	.95	.96	.52	.98	1.01	.29	.50	1.00	1.05
	Load Amps		1.04	1.04	1.04	1.04	1.04	2.08	2.08	1.04	2.08	2.08	1.25	1.15	2.19	2.19
100BB2448Q .100 KVA	KVA		.58	.87	.95	.97	.99	1.90	1.93	1.03	1.97	2.01	.58	1.00	2.00	2.10
	Load Amps		2.08	2.08	2.08	2.08	2.08	4.17	4.17	2.08	4.17	4.17	2.50	2.29	4.38	4.38
150BB2448Q .150 KVA	KVA		.86	1.31	1.43	1.46	1.48	2.86	2.89	1.55	2.95	3.02	.86	1.50	3.00	3.15
	Load Amps		3.13	3.13	3.13	3.13	3.13	6.25	6.25	3.13	6.25	6.25	3.75	3.44	6.56	6.56
205BB2448Q .250 KVA	KVA		1.44	2.18	2.38	2.43	2.46	4.76	4.81	2.58	4.92	5.03	1.44	2.50	5.00	5.25
	Load Amps		5.21	5.21	5.21	5.21	5.21	10.42	10.42	5.21	10.42	10.42	6.25	5.73	10.94	10.94
505BB2448Q .500 KVA	KVA		2.88	4.35	4.77	4.87	4.93	9.52	9.62	5.16	9.83	10.06	2.88	5.00	10.00	10.50
	Load Amps		10.42	10.42	10.42	10.42	10.42	20.83	20.83	10.42	20.83	20.83	12.50	11.46	21.88	21.88
705BB2448Q .750 KVA	KVA		4.31	6.53	7.15	7.30	7.39	14.28	14.44	7.73	14.75	15.09	4.31	7.49	15.00	15.75
	Load Amps		15.63	15.63	15.62	15.63	15.63	31.25	31.25	15.63	31.25	31.25	18.75	17.19	32.81	32.81
1BB2448Q 1.00 KVA	KVA		5.75	8.71	9.53	9.74	9.85	19.04	19.25	10.31	19.67	20.13	5.75	9.99	20.00	21.00
	Load Amps		20.83	20.83	20.83	20.83	20.83	41.67	41.67	20.83	41.67	41.67	25.00	22.92	43.75	43.75
105BB2448Q 1.50 KVA	KVA		8.63	13.06	14.30	14.61	14.78	28.56	28.88	15.47	29.50	30.19	8.63	14.99	30.00	31.50
	Load Amps		31.25	31.25	31.25	31.25	31.25	62.50	62.50	31.25	62.50	62.50	37.50	34.38	65.63	65.63
2BB2448Q 2.00 KVA	KVA		11.50	17.42	19.07	19.48	19.71	38.08	38.50	20.63	39.33	40.25	11.50	19.98	40.00	42.00
	Load Amps		41.67	41.67	41.67	41.67	41.67	83.33	83.33	41.67	83.33	83.33	50.00	45.83	87.50	87.50
3BB2448Q 3.00 KVA	KVA		17.25	26.13	28.60	29.22	29.56	57.13	57.75	30.94	59.00	60.38	17.25	29.98	60.00	63.00
	Load Amps		62.50	62.50	62.50	62.50	62.50	125.00	125.00	62.50	125.00	125.00	75.00	68.80	131.25	131.25
5BB2448Q 5.00 KVA	KVA		28.75	43.54	47.67	48.70	49.30	95.20	96.20	51.56	98.30	100.60	28.80	50.00	100.00	105.00
	Load Amps		104.17	104.17	104.17	104.17	104.20	208.30	208.30	104.17	208.30	208.30	125.00	114.60	218.75	218.75
Connection Diagram (pg. 7-24)			B	D	D	D	D	C	C	D	C	C	B	D	C	C

Three Phase — Table 6			Boosting							Bucking								
Catalog Number	Line Voltage (Available)		399Y/ 230	380	430	440	460	460	480	480	440	440	460	460	480	480	500	500
Insulating Transformer Rating	Load Voltage (Output)		480Y/ 277	418	473	462	506	483	528	504	400	419	438	418	457	436	455	476
050BB2448Q .050 KVA	KVA		.86	.75	.85	1.66	.91	1.74	.95	1.82	.79	1.58	1.66	.83	1.73	.86	.90	1.80
	Load Amps		1.04	1.04	1.04	2.08	1.04	2.08	1.04	2.08	1.14	2.18	2.18	1.14	2.18	1.14	1.14	2.19
100BB2448Q .100 KVA	KVA		1.73	1.51	1.70	3.33	1.82	3.48	1.90	3.63	1.59	3.17	3.31	1.66	3.46	1.73	1.80	3.61
	Load Amps		2.08	2.08	2.08	4.16	2.08	4.16	2.08	4.16	2.29	4.37	4.37	2.29	4.37	2.29	2.29	4.38
150BB2448Q .150 KVA	KVA		2.60	2.26	2.56	4.99	2.73	5.22	2.85	5.45	2.38	4.75	4.97	2.48	5.19	2.59	2.70	5.41
	Load Amps		3.12	3.13	3.12	6.24	3.12	6.25	3.12	6.24	3.43	6.55	6.55	3.43	6.55	3.43	3.43	6.56
205BB2448Q .250 KVA	KVA		4.33	3.77	4.26	8.32	4.56	8.70	4.76	9.08	3.96	7.92	8.28	4.14	8.64	4.32	4.51	9.02
	Load Amps		5.20	5.21	5.20	10.40	5.20	10.40	5.20	10.40	5.72	10.92	10.92	5.72	10.92	5.72	5.72	10.94
505BB2448Q .500 KVA	KVA		8.60	7.54	8.52	16.64	9.11	17.40	9.51	18.16	7.93	15.85	16.57	8.28	17.29	8.64	9.02	18.04
	Load Amps		10.40	10.42	10.40	20.80	10.40	20.80	10.40	20.80	11.44	21.84	21.84	11.44	21.84	11.44	11.44	21.88
705BB2448Q .750 KVA	KVA		12.90	11.31	12.77	24.97	13.67	26.10	14.27	27.24	11.89	23.77	24.85	12.42	25.93	12.96	13.52	27.06
	Load Amps		15.60	15.63	15.60	31.20	15.60	31.20	15.60	31.20	17.16	32.76	32.76	17.16	32.76	17.16	17.16	32.81
1BB2448Q 1.00 KVA	KVA		17.30	15.08	17.03	33.29	18.23	34.80	19.02	36.31	15.85	31.70	33.14	16.57	34.57	17.28	18.03	36.08
	Load Amps		20.80	20.83	20.80	41.60	20.80	41.60	20.80	41.60	22.88	43.68	43.68	22.88	43.68	22.88	22.88	43.75
105BB2448Q 1.50 KVA	KVA		25.90	22.62	25.55	49.93	27.34	52.50	28.53	54.47	23.78	47.55	49.71	24.85	51.86	25.92	27.05	54.13
	Load Amps		31.20	31.25	31.20	62.40	31.20	62.40	31.20	62.40	34.32	65.52	65.52	34.32	65.62	34.32	34.32	65.63
2BB2448Q 2.00 KVA	KVA		34.60	30.17	34.07	66.58	36.46	69.60	38.04	72.63	31.70	63.40	66.27	33.13	69.15	34.56	36.06	72.17
	Load Amps		41.60	41.67	41.60	83.20	41.60	83.20	41.60	83.20	45.76	87.36	87.36	45.76	87.36	45.76	45.76	87.50
3BB2448Q 3.00 KVA	KVA		52.00	45.25	51.18	100.03	54.69	104.57	57.07	109.12	47.63	95.25	99.57	49.77	103.89	51.92	54.18	108.25
	Load Amps		62.50	62.50	62.50	125.00	62.50	125.00	62.50	125.00	68.75	131.25	131.25	68.75	131.25	68.75	68.75	131.25
5BB2448Q 5.00 KVA	KVA		86.10	75.42	85.17	166.44	91.15	174.01	95.11	181.57	79.26	158.50	165.69	82.83	172.87	86.39	90.16	180.42
	Load Amps		104.00	104.17	104.00	208.00	104.00	208.00	104.00	208.00	114.40	218.40	218.40	114.40	218.40	114.40	114.40	218.75
Quantity Required			3	2	2	2	2	2	2	2	2	2	2	2	2	2	2	2
Connection Diagram (pg. 7-24)			E	G	G	H	G	H	G	H	G	H	H	G	H	G	G	H

☐ = Warehouse Stock

• Output voltage for lower input can be found by:
 $\frac{\text{Rated Output Voltage}}{\text{Rated Input Voltage}} \times \text{Input Actual Voltage} = \text{Output New Voltage}$

• Output KVA available at reduced input voltage can be found by:
 $\frac{\text{Actual Input Voltage}}{\text{Rated Input Voltage}} \times \text{Output KVA} = \text{New KVA Rating}$

• Inputs and outputs may be reversed without affecting KVA capacity. See note on page 7-24.

Buck-Boost Transformers

Single Phase, Three Phase

Typical Connection Diagrams

Single Phase

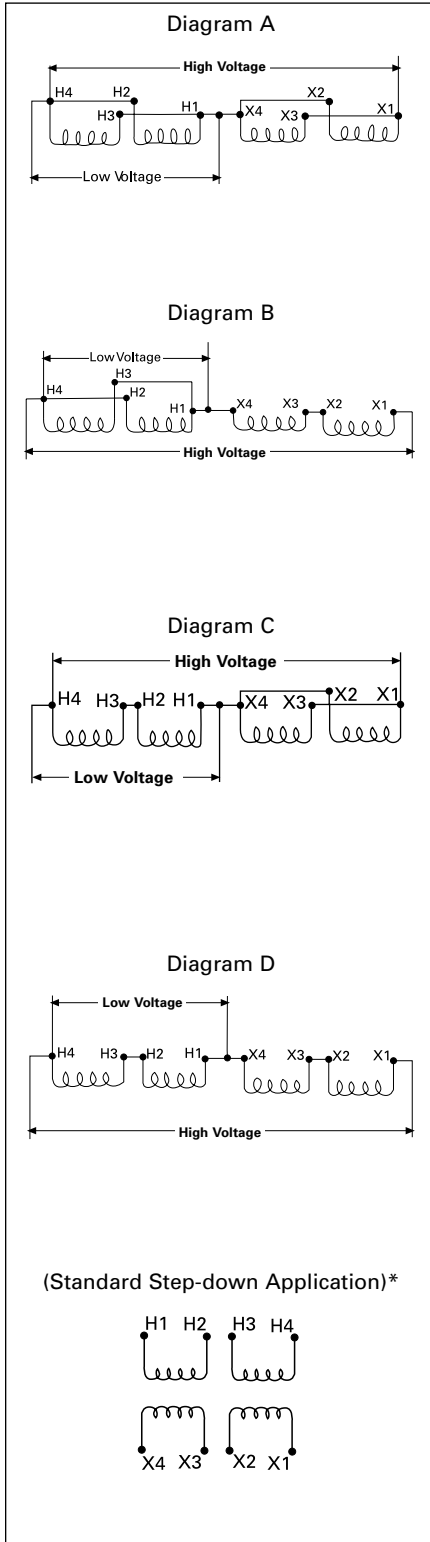

Three Phase

Note: Contact sales office for diagrams applicable to "Q" suffix.

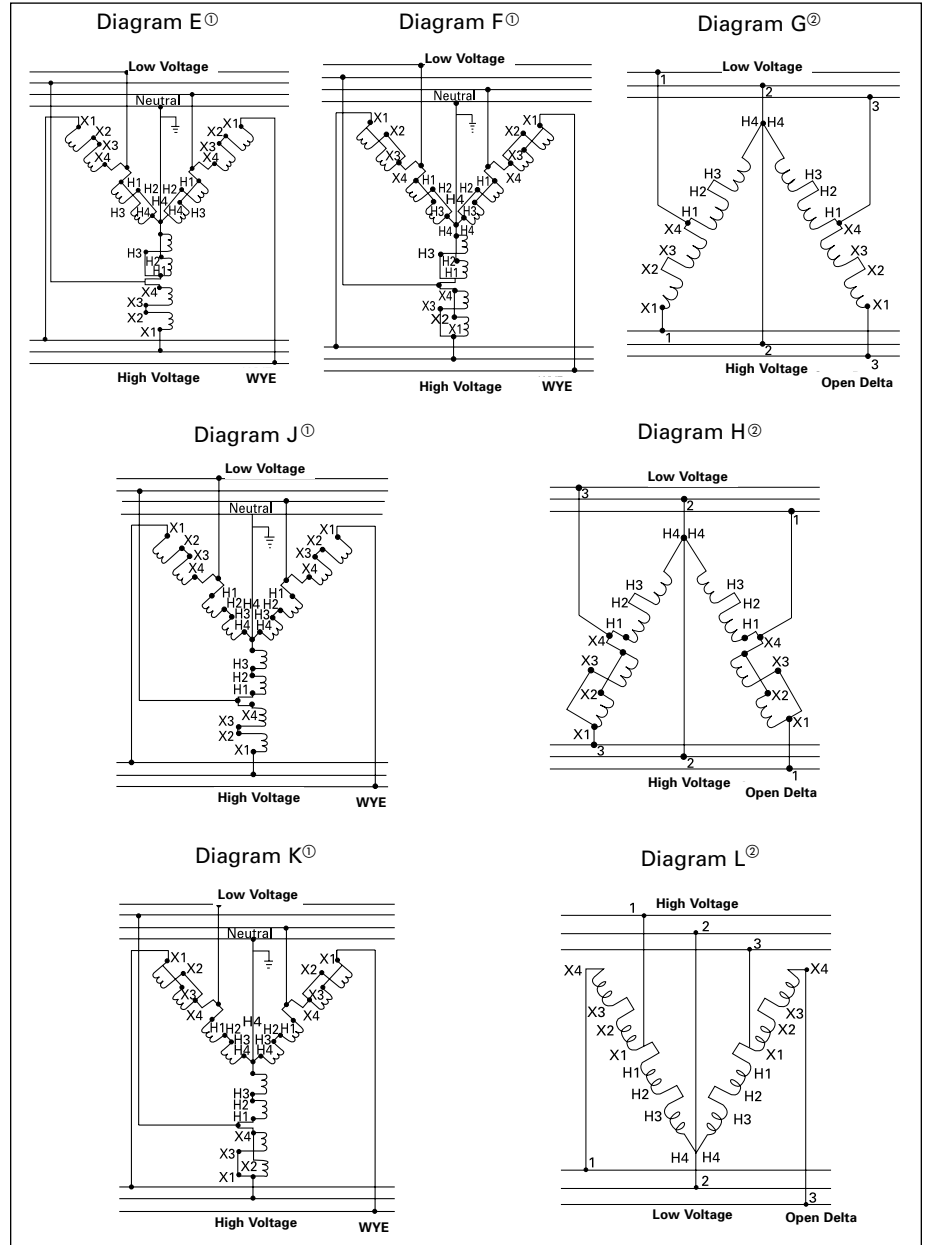

*Low Voltage Applications:

By using the "Standard Step-down Application" diagram at left, buck boost transformers will convert 120V or 240V to 12, 24, 16 or 32 volts and 240V or 480V to 24 or 48 volts without affecting the nameplate KVA rating of the transformer. Buck boost transformers used in this type of application will become isolation or insulating type transformers.

① These diagrams can only be used when the source is a 4-wire supply.
 ② The neutral XO should not be used when the source is a three wire supply.

Note:

- Inputs and Outputs may be reversed; KVA capacity remains constant. Exception: Cannot use 3-wire input with 4-wire output to form a neutral and does not apply to standard step-down applications.
- Refer to NEC 450-4 for overcurrent protection of an autotransformer.

• All applications are suitable for 60Hz only.