

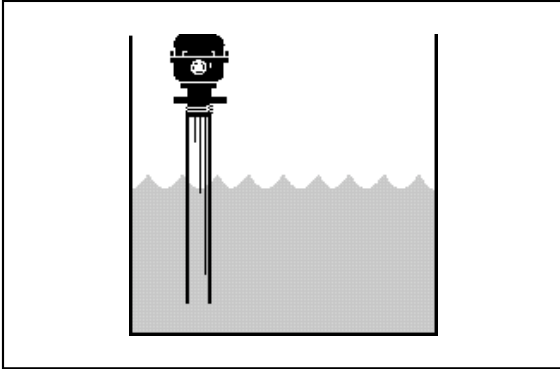

Remote Sensor Location

The location of the remote sensor is not limited to mounting on top of a tank. Depending on the application, it may be decided to mount the remote sensor in a stillwell or equalizing line. The following diagrams show typical locations for several applications.



Open tanks or vessels will probably require mounting the remote sensor on a stillwell to dampen the liquids' wave action. Use 3" or 4" perforated plastic drain pipe with a flange to thread connection at the top. The stillwell can rest on the bottom of the tank or be suspended and secured with brackets.

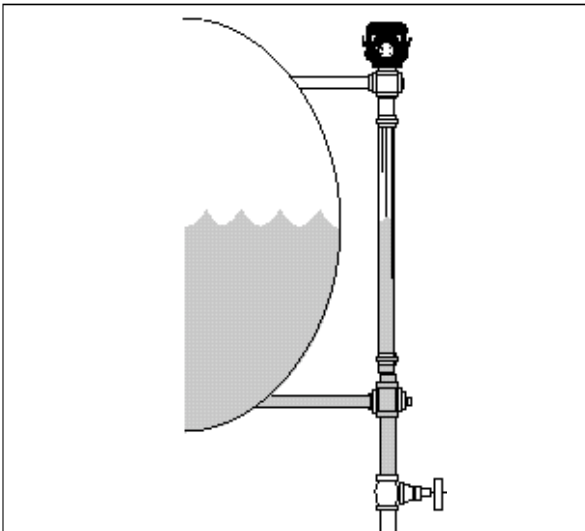

Mounting the remote sensor in an equalizing pipe is an alternative to top mounting. The equalizing pipe should be at least a 2" pipe and have a drain valve at the bottom for flushing.

Probe Installation

All boiler manufacturers designate the preferred (and sometimes secondary) location for installation of the probe on their boiler. They have determined that this location is above the minimum safe water level and provides the 1/4" clearance needed to ensure the probe is not grounded. Always install the probe in these locations, especially on a hot water boiler. If installed in other locations on a hot water boiler, this area could be prone to develop an air pocket.

Installation in piping external to the boiler on hot water systems has its own pitfalls. The first problem is if the probe is too long. If the probe touches the wall of the pipe, the circuit is completed and the LWCO "thinks" there is water in the system. If the water level drops below the level of the probe in this situation, the burner circuit will never be interrupted and a dry-fire could occur.

The most common problem with installation on hot water systems occurs when installing the probe in copper pipe. The sweat to thread adapters installed could result in the probe not being inserted in the pipe. An air pocket could develop or scale bridging could occur. While an air pocket causes nuisance shutdown of the boiler, scale bridging can result in a dry-fire if the water drops below the level of the probe. Always make sure at least 1/2 the length of the probe is in the run of the pipe to ensure proper operation.

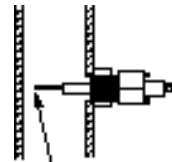

Make sure tip of probe is in pipe with 1/4" clearance from wall of pipe.

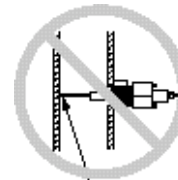

If probe is installed too close to boiler wall, an electrical short could occur.

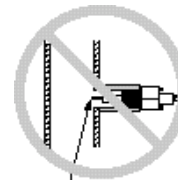

If probe is installed with extensions, an air pocket could develop shutting down the boiler. Debris could develop which can cause an electric short, rendering the low water cut-off ineffective.

Liquid Level Controls

750B Series

OPERATION AND SELECTION

A conductance-type control will sense liquids up to 60,000 ohms resistivity. It can be used to activate a low level alarm, high level alarm, pumps to fill/drain a tank or any combination thereof. Typical applications include, but are not limited to, cooling towers, storage tanks, water fountains and condensate receivers.

The control utilizes the conductivity of a liquid to make or break circuits. Some liquids may be more resistive than the control can sense (above 60,000 ohms). The resistive and conductive properties of a liquid depend on several factors, including the amount of soluble material, temperature of the liquid, and placement of the probes. A TDS tester, which can be purchased from a supply house carrying boiler chemicals, is required to accurately measure a liquid's resistivity.

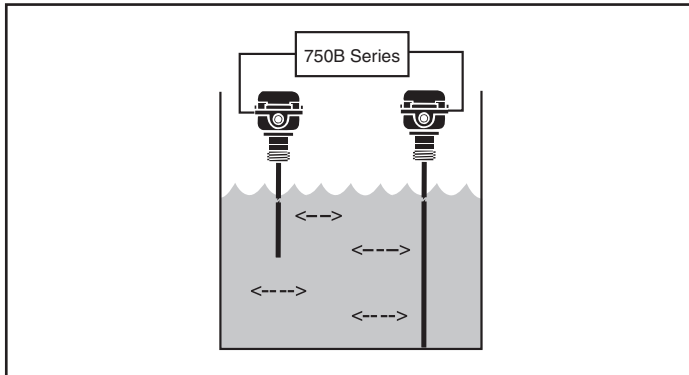

For many applications, water is the liquid being sensed. Raw or tap water usually has naturally occurring salts, chlorides and minerals that make it conductive enough to operate the control. Condensate receiver and cooling tower water are also very conductive due to evaporation. Ultrapure water (RO, deionized, demineralized, etc.) is highly resistive and is not able to conduct the current needed to operate the control.

Refer to the following charts to determine the resistivity of the liquid in an application. If it is above the 60,000 ohm rating, another type of control will be required.

Conductivity Values of Water

Liquid	Resistivity (Ohms/cm)	Conductivity (Micromhos/cm)	LPC Can Be Used
Water - Deionized	2,000,000	0.5	
Water - Distilled	450,000	2	
Water - Condensate	18,000	50	X
Water - Chlorinated	5,000	200	X
Water - Hard/Natural	5,000	200	X
Water - Sewage	5,000	200	X
Water - Salt	2,200	450	X

Converting Total Dissolved Solids to Resistivity and Conductivity

Total Dissolved Solids (ppm)	Resistivity (Ohms/cm)	Conductivity (Micromhos/cm)
0.0277	18,000,000	0.056
0.0417	12,000,000	0.084
0.0833	6,000,000	0.167
0.500	1,000,000	1.00
1.25	400,000	2.50
10.0	50,000	20.0
100	5,000	200
1,000	500	2,000
10,000	50	20,000

Multi Purpose Level Controls For Steam and Hydronic Applications

Series 750B

Conductance Actuated Level Controls

- For commercial or industrial applications
- Low water cut-off, pump on, pump off, or high level alarm
- 24 VAC and 120 VAC models
- Panel and plug-in modular mount electronics
 - LWCO
 - Feed Water/Pump Control
- Automatic or manual reset option on each board
- Maximum circuit board ambient temperature 150°F (51°C)
- 26,000 ohm sensitivity
- Manual reset models meet the requirements of **ASME Standard CSD-1**. If the control is in a low water condition when there is an interruption of power, the control will remain in a low water condition when power is restored. The reset button will need to be pressed when the water level is restored to a level above the probe to allow the burner to fire.

Ordering Information

1. Select and order panel mount or plug-in module 750B control unit.
 2. Select and order appropriate chamber based on the number of levels to be sensed.
- (Order sensor chamber and probes separately (see page 72-75))

Model Number	Part Number	Description	Weight lbs. (kg)
Panel Mount			
750B-L-24-C-03	176300	Low water cut-off	0.5 (0.2)
750B-L-120-C-03	176302	Low water cut-off	0.5 (0.2)
750B-P-120-CI	176304	Pump controller	0.5 (0.2)
Plug-In Module			
750BM-L-24-C-03	176305	Low water cut-off	0.6 (0.3)
750BM-L-120-C-03	176307	Low water cut-off	0.6 (0.3)
750BM-P-120-CI	176309	Pump controller	0.6 (0.3)
Plug-In Module Sockets			
750BM-8PS	176310	Eight pin socket (for "P" models)	0.3 (0.1)
750BM-11PS	176311	Eleven pin socket (for "L" models)	0.3 (0.1)

Electrical Ratings

Model	Voltage	Switch Contact Ratings	
		Full Load	Locked Rotor
24 VAC	24 VAC	—	—
120 VAC	120 VAC	7.2	43.2
	240 VAC	3.75	21.6

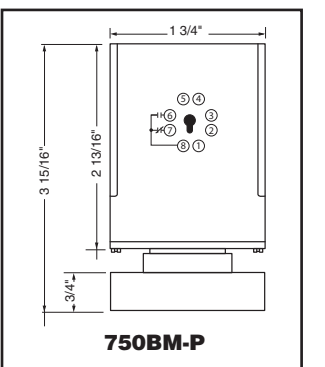
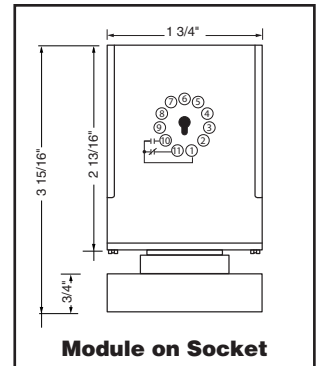
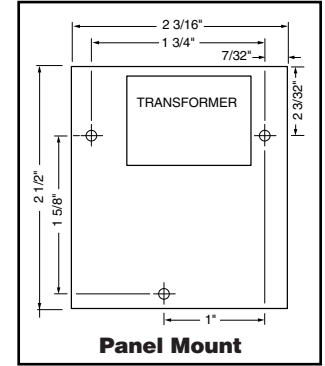
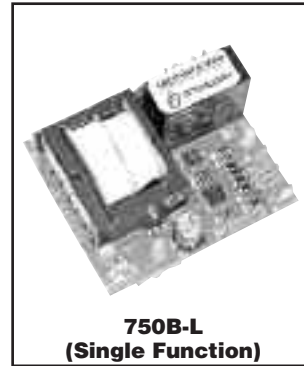

Multi Function Controls

750B-LP



Combines 1-Level relay action with a differential 2 level relay on one board for pump/feeder and cut-off/alarm.

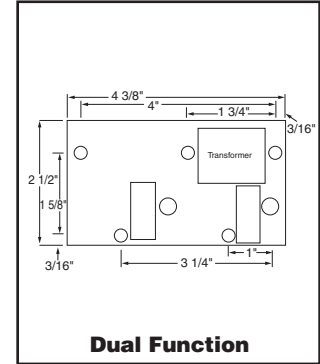
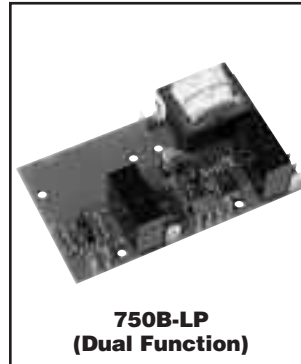

750B-DLP

Combines (2) 1-Level relay action with a differential 2-level relay on one board for both high and low or redundant low water cut-off/alarm and pump/feeder. Direct replacement for obsolete LPC 2000 control.

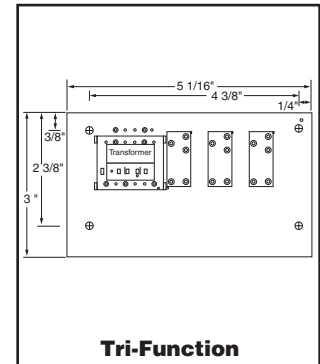
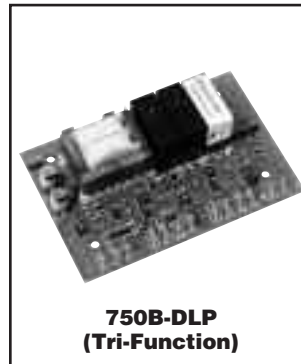

Ordering Information

1. Select and order panel mount or plug-in module 750B control unit.
 2. Select and order appropriate chamber based on the number of levels to be sensed.
- (Order sensor chamber and probes separately (see page 72-75))

Model Number	Part Number	Description	Weight lbs. (kg)
Panel Mount			
750B-DLP-120-CI-03	176314	Dual LWCO & Pump controller	0.6 (0.3)
750B-LP-120-CI-03	176312	LWCO & Pump controller	0.6 (0.3)
Mounting Accessories			
Adaptor-750	176320	PCB adaptor plate kit	0.3 (0.1)
750B-ENC	176345	NEMA 1 enclosure includes adaptor plate	1.9 (0.9)



Electrical Ratings

Model	Voltage	Switch Contact Ratings	
		Full Load	Locked Rotor
120 VAC	120 VAC	7.2	43.2
	240 VAC	3.75	21.6