

**No Lead Two-Level SwirlFlo®
Wall Mount Water Cooler
Barrier-Free Access
Model ERPBM28C**



SPECIFICATIONS

GENERAL

Fully exposed dual height stainless steel fountains have recessed in-the-wall refrigeration system and stainless steel grill. Stainless steel tubular support arms incorporate unique recess to be integrated with basins. All stainless steel polished to lustrous satin finish with high shined outer edge. Fountains have contoured basins to minimize splashing. Flexi-Guard® safety bubblebers and easy to operate, fully functional vandal-resistant front push button. Patented* valve and in-line flow regulators provide constant stream from 20 to 105 psi.

Energy efficient refrigeration system utilizes a combination tank continuous-tube type evaporator, refrigerant drier, and capillary tube.

THIS WATER COOLER COMPLIES WITH THE REQUIREMENTS OF A.D.A. (AMERICANS WITH DISABILITIES ACT) PROVIDING THE UNIT IS INSTALLED IN AN ALCOVE OR WITH LEFT WING WALL.

NO LEAD DESIGN

THIS WATER COOLER COMPLIES WITH THE LEAD-FREE DEFINITION IN THE SAFE DRINKING WATER ACT OF 1986 AND LEAD CONTAMINATION CONTROL ACT OF 1988.

Elkay Water Coolers are manufactured with a waterway system utilizing copper components and completely lead-free material. These waterways have no lead because all lead materials, such as leaded brass, have been removed. All joints are brazed using silver solder only. No lead solder is permitted. A strainer with an easily cleanable screen is provided to allow trapping and convenient removal of waterborne particulate of 140 microns and larger prior to their entry into the water cooler.



This water cooler is classified by Underwriters Laboratories Inc. in accordance with **ANSI/NSF61, Section 9-1997b.**

CAPACITIES CHART

| Model Number | Base Rate | *GPH of 50°F Drinking Water | | | Rated Watts | Full Load Amps | Glass Filler Option | Pre-Cooler | Ship. Wt. Lbs. |
|--------------|-----------|-----------------------------|------|------|-------------|----------------|---------------------|------------|----------------|
| | | Room Temperature °F | | | | | | | |
| | | 70°F | 80°F | 90°F | | | | | |
| ERPBM28C | 7.5 | 8.6 | 8.1 | 7.5 | 325 | 4.5 | No | No | 140 |

**Based on 80°F inlet water temperature.

Rated watts shown are based on operational (run) time, in accordance with A.R.I. Standard 1010 conditions. Specific applications will determine the actual watts consumed per hour. Watts consumed will be based on number of people served per hour (usage), ambient temperatures, and inlet water temperature.

COOLING SYSTEM

Motor Compressor: Hermetically sealed, reciprocating type, 115V, 60 Hz or 230V, 50 Hz (International Model) single phase. Sealed-in lifetime oil supply.

Condenser: Fan cooled, copper tube with aluminum fins. Fan motor is permanently lubricated.

Cooling Unit: Combination tube-tank type. Self cleansing. Tube portion is continuous coil of copper tubing. Tank is stainless steel. Fully insulated with EPS foam which meets Underwriters Laboratories Inc. requirements for self extinguishing material.

Temperature Control: Enclosed adjustable thermostat is factory preset. Requires no adjustment other than for altitude requirements.

Refrigerant Control: Refrigerant HFC-134a is controlled by accurately calibrated capillary tube for positively trouble-free performance.

In keeping with our policy of continuing product improvement, Elkay reserves the right to change product specifications without notice.

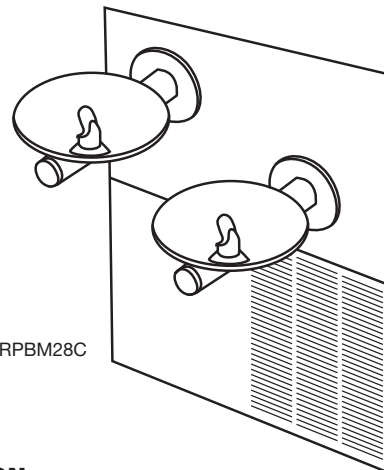

Model ERPBM28C

CONSTRUCTION

Fountain Body: #18 gauge, type 304 nickel bearing stainless steel polished to a lustrous satin finish with high shined outer edge. Contoured basin offers large strike area to minimize splashing. #16 gauge, type 304 tubular support arms incorporate unique recess to accept basins. Fully functional vandal-resistant push buttons are easy to operate.

Exclusive Flexi-Guard® Safety Bubbleber*: Innovative design utilizes a pliable polyester elastomer to prevent accidental mouth injuries. Flexes on impact, then returns to original position. Strong. Abrasion-resistant. Anti-sweat. **Optional Vandal-Resistant Bubbleber** available at extra cost. Heavy duty, one-piece construction, chrome plated brass. **Order Model Number ERPBMV28C.** Both bubblebers meet UL requirements and all sanitary codes and are keyed in location to prevent rotation.

Front Panel Grill: Made of type 304 stainless steel, polished to a uniform Elkay satin finish. Removable louvered ventilating grill encloses refrigeration unit and plumbing.

Wall Mounting Frame: MF200 frame furnished with each unit. Frame allows flush mounting to finished wall.

5 YEAR LIMITED WARRANTY on the refrigeration system of the unit. Electrical components and water system are warranted for 12 months from date of installation. Sample Certificate available on request.

Elkay Pressure-Type Water Coolers are designed to operate on 20 psi to 105 psi supply line pressure. If inlet pressure is above 105 psi, a pressure regulator must be installed in the supply line. Any damage caused by reason of connecting this product to supply line pressures lower than 20 psi or higher than 105 psi is not covered by the warranty.

STANDARDS



Elkay Electric Air Cooled Water Coolers are listed by Underwriters Laboratories Inc. and comply with both Canadian and U.S. requirements.



Rated in accordance with A.R.I. Standard 1010 and meets all known federal and state plumbing codes.

* Patent #4,481,971

This specification describes an Elkay product with design, quality and functional benefits to the user. When making a comparison of other producers' offerings, be certain these features are not overlooked.

**No Lead Two-Level SwirlFlo®
Wall Mount Water Cooler
Barrier-Free Access
Model ERPBM28C**

ELKAY®

ROUGH-IN DIMENSIONS

**IMPORTANT!
INSTALLER PLEASE NOTE:**

The grounding of electrical equipment such as telephone, computers, etc., to water lines is a common procedure. This grounding may be in the building or may occur away from the building. This grounding can cause electrical feedback into a water cooler, creating an electrolysis which causes a metallic taste or causes an increase in the metal content of the water. This condition is avoidable by using the proper materials as indicated below.

The drain fittings which are provided by the installer should also be plastic to electrically isolate the cooler from the building plumbing system.

ERPBM28C MOUNTING FRAME INSTRUCTIONS

1. Cut a square rectangular wall opening 37-1/2" (953mm) W x 37-3/4" (959mm) H and 4-1/2" (114mm) above the floor line. These dimensions are required to obtain proper rim and bubbler heights for compliance with ANSI standard A117.1. (See Figure 2)

2. Reinforce the wall opening on all sides so that it will adequately support the water fountain. This reinforcement must support up to 150 lbs static load and provide a means for securing the frame assembly in place.

NOTE: Building construction must allow for adequate air flow on both sides and top of remote chiller unit. Minimum of 4" (102mm) is required. (See Figures 1 & 2)

3. Install plumbing and electrical rough-ins. See Figure 1 for location of the supply water inlet to chiller and for the location of the waste water outlet. A junction box for a (3) wire, 10 amp branch circuit is provided on the inside of the chiller. (Standard 120 Volts, 60 Hz and single phase) See Figure 2 for the electrical inlet location.

4. Remove frame assembly and related hardware from packaging. Attach the two frames together thru the upright supports with (4) 5/16" x 3/4" (19mm) long bolts and nuts (not provided). Tighten securely.

NOTE: Frame with higher upper channel to be on left side.

5. Install the frame assembly squarely in wall opening with frame upright support edges flush with the finished wall face. Secure the frame to the wall thru holes with (12) 5/16" x 2" (51mm) long lag bolts or screws (not provided). Tighten securely.

NOTE: Be sure that frame is squared in location. Do not use less than required screw quantity and size.

6. Attach the chiller shelf support rods to the right side frame uprights at the second set of holes counting from the bottom and to the shelf at the (2) side holes. Line up the other shelf holes with the frame bottom holes and fasten the assembly to the wall using appropriately sized wood screws or bolts and nuts (not provided). (See Figure 2)

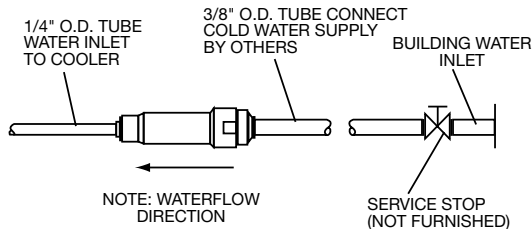

OPERATION OF QUICK CONNECT FITTINGS

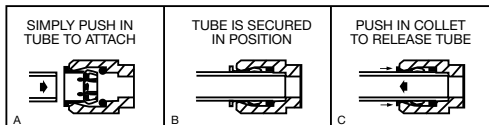

FIG. 1

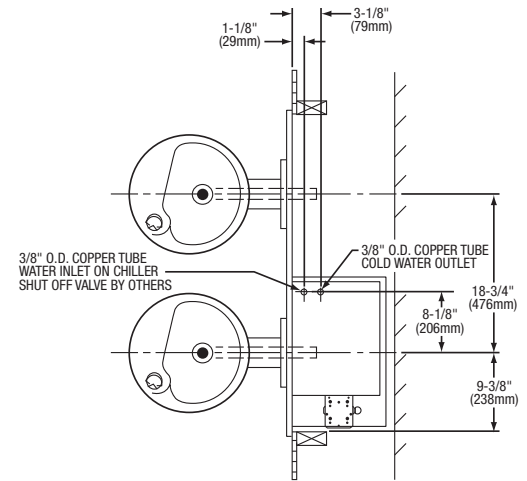

FIG. 2

