

MB•32/MB•24/MB•16/MB•E 8•BUS METER BRIDGES

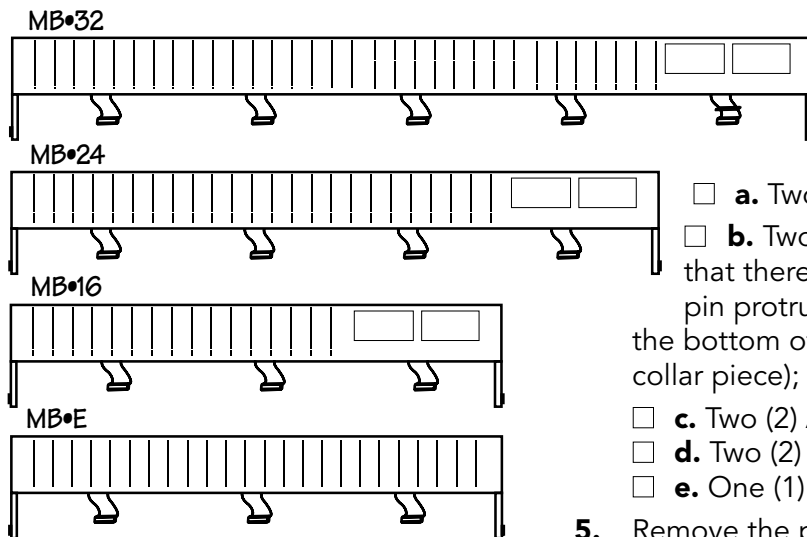

4. Locate and identify the hardware that came with your Meter Bridge:

- a. Two (2) slotted screws;
- b. Two (2) collar pieces (Note that there is a small pin protruding from the bottom of each collar piece);
- c. Two (2) Allen head screws;
- d. Two (2) lockwashers;
- e. One (1) allen wrench.

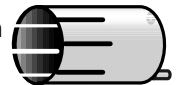

5. Remove the plastic caps that cover the Meter Bridge mounting holes on each side of the Console (Drawing A). Feed them to your boa.

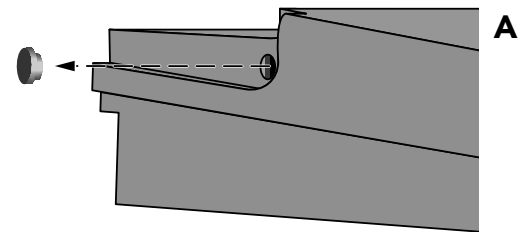

Congratulations on adding a Meter Bridge to your Mackie Designs 8•Bus Console. Installation is very straightforward and should take just a few minutes. The only reason we've included so many step-by-step drawings is because our art department wanted something to do on a rainy day¹.

INSTALLATION INSTRUCTIONS

1. Locate the warranty card and fill it out. If you bought your Meter Bridge at the same time you purchased an 8•Bus series console, you don't need to answer all the questions on the card that came with the Meter Bridge. Just fill in the model number of the Meter Bridge, serial number, purchase date and dealer, and your name and address.
2. Make sure that your 8•Bus Console power supply is turned off.
3. Remove the Meter Bridge from its plastic bag. Save the bag. It's handy for wrapping boa constrictors or moray eels before popping them in your freezer. Also, save the box.

6. Align the Meter Bridge with the Console (B) and lower it into place. Tilt the Meter Bridge back until it is at rest against the Console chassis (or your tangle of patchcords). Make sure that the meter bridge's mounting holes line up

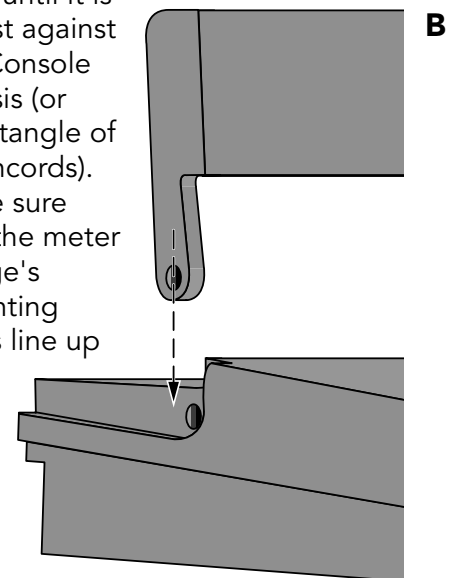

¹And, since every day except four or five in August are rainy up here in the Northwest Rainforest, they had time to do quite a nice job.

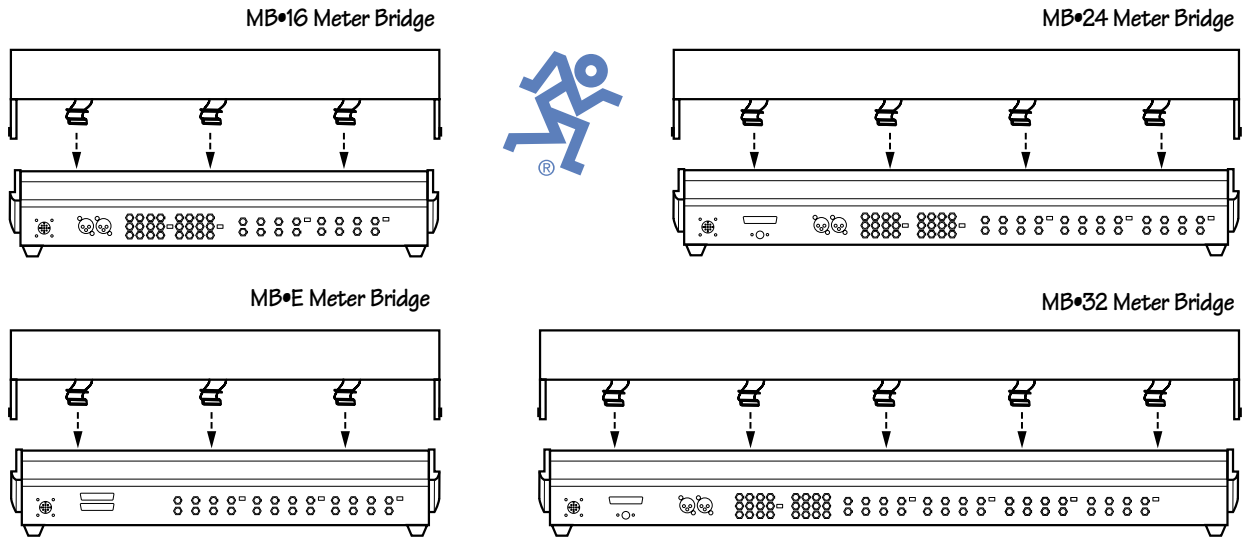

E

with the console's mounting holes.

- Hand-insert one collar piece into each side, with the "teeth" pointing out (C). Occasionally, the end caps of the Console will try

C

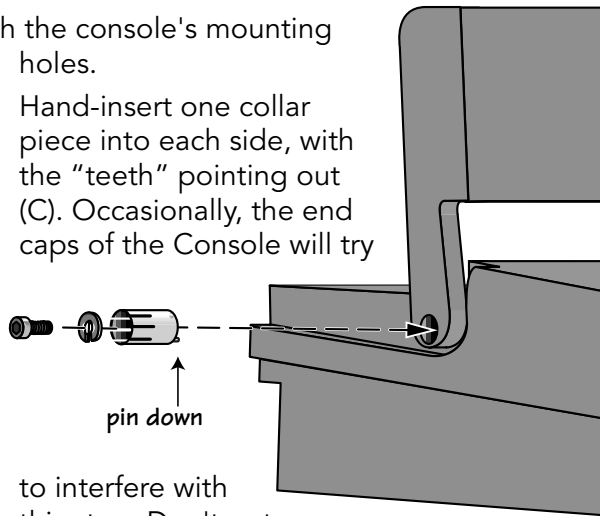

to interfere with this step. Don't get upset. Simply loosen the CONSOLE end cap screws, install the collar and then re-tighten the screws.

- Turn the collars by hand until you feel the pin seat itself (it will stop turning).
- Slide one lockwasher onto each allen-head screw.
- Secure the collars by inserting an Allen-head screw on each side (C). Take care not to cross-thread the screws or strip the screwheads. Tighten the Allen screws securely.
- Using a hefty screw driver, install a flush screw almost all the way into each side (Drawing D at right).
- Raise the Meter Bridge as far forward as it will go.
- On the Console, locate the rubber plugs that cover the Meter Bridge ribbon cable

sockets. The 32•8 has five; the 24•8 has four; the 16•8 and MB•E each have three (see epic MondoDrawing E at the top).

- Remove the rubber plugs and feed them to the afore-mentioned boa constrictor.
- Making sure that the plug and socket are aligned, firmly insert each ribbon cable into its corresponding socket in the Console (F). Take care to make sure that the cable is *not* twisted 180° (sounds insulting to caution you against something like this, but we've seen it done.) Unless your fingers are microminiature, you'll probably need to use the eraser end of a pencil to press down on the plug and make sure that it is fully seated (G).
- Slide the new improved, slotted rubber plugs (that are pre-attached to the ribbon cables) down until they fit snugly into the rectangular Console holes (Drawing H).
- Adjust the Meter Bridge to the desired angle and tighten the screws.
- Make yourself a sandwich. Wash hands before returning to work.

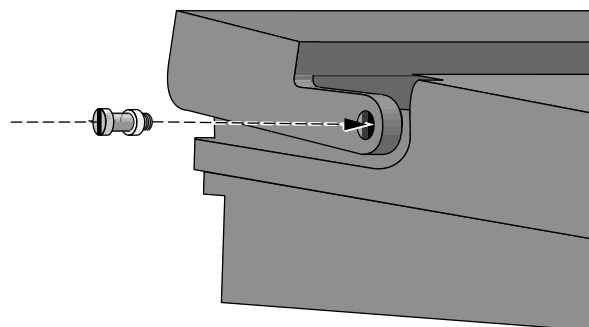

D

A SHORT TEST-DRIVE

The point of this exercise is to make sure that all the Meter Bridge channels (and all the LED's on each channel) work properly. Better now than later.

1. Power up your 8•Bus Console. Confirm that the following are alight:
 - A. The console's power LED;
 - B. The meter bridge's VU meters (unless you're installing an MB•E); and
 - C. Either the TAPE or CHANNEL LED on the Meter Bridge.

If nothing lights up, turn the power off immediately and re-check your connections. If all is aglow, proceed to the next step.

2. If the Meter Bridge TAPE LED is on, press the SOURCE button below it once to switch to CHANNEL. If the CHANNEL LED is on, switch it to TAPE and back to CHANNEL, to confirm that the switch is behaving.

3. Send a signal into the main path of Console Channel 1. The -20 LED above the fader will let you know if you have done so.

4. After making sure that the channel is not muted, turn up the channel fader. Confirm Meter

Bridge activity on Channel 1. Whoop with unbridled joy.

5. Repeat steps 3 and 4 for each channel of the Console. You'll probably want to stop whooping after about the sixth or seventh channel.
6. Assign the last channel you tested to the L/R MIX. Turn up the L/R MIX fader. Engage the L/R switch in the MONITOR section of the Console.
7. Confirm meter activity on both the Meter Bridge VU meters and the console's L/R MAIN LED meters. Pan the channel left and right to confirm that all meters understand this sort of thing.

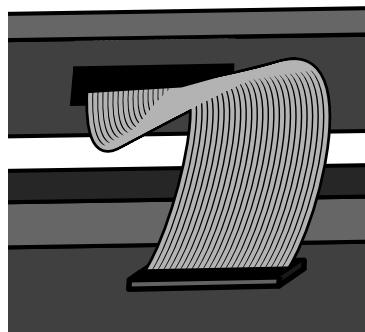
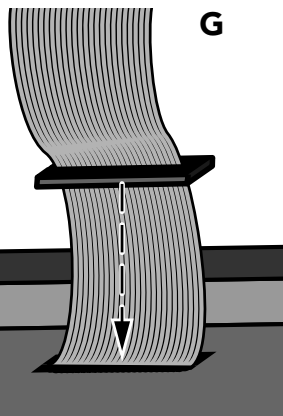
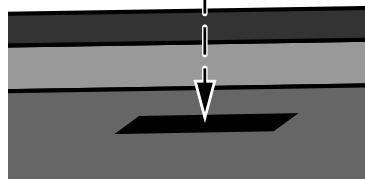
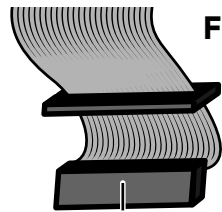

H

continued on back page

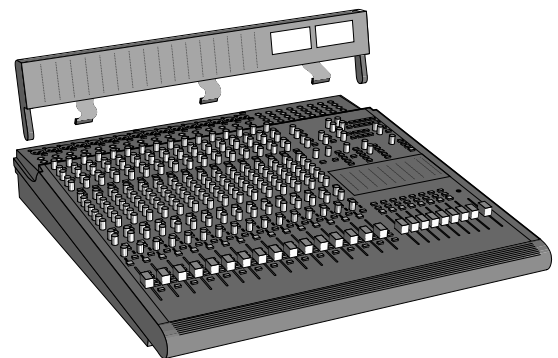

TROUBLESHOOTING

If a group of LED ladders doesn't respond, there's a good chance that the corresponding ribbon cable isn't pushed in all the way. Make sure that it is firmly plugged in.

If nothing responds, contact your dealer or Mackie Designs Tech Support immediately.

METER BRIDGE OPERATION

Your meter bridge's ballistics and general behavior is the same as the submaster LED ladders on the Master section of the Console. For the excruciating details, read the section on METERING on page 11 of your 8•Bus manual.

When TAPE is selected on the Meter Bridge, the channel meters will show you what is coming out of your multitrack into your tape returns — before any signal manipulation in the channel (but after the +4/-10 switching circuit). The channel meters should behave just like your multitrack's meters.

When CHANNEL is selected, the meters “see” the channel's direct output post-EQ, post-fader and post-mute. This is particularly handy for live mixing.

The VU meters on the MB•32, MB•24 and MB•16 “look” at the same signals as the console's L/R LED meters. You will notice that the VU meters and LED meters will not always agree with each other. THIS IS NORMAL. The LED meters read peak activity and will show every dynamic nuance. The VU meters, designed in the Early Bronze Age, are slower to respond and therefore show an RMS or average signal level. This will usually be several dB less than the peaks shown on the LED meter.

Final suggestion: Turn your overhead lights way down so that your Mackie system will look like the Death Star from Revenge of the Jedi. Put baseball cards in the power supply fan to simulate a warp drive.

Just kidding.

