

**Maximum Load Capacity: 50 lb (22.7 kg)****Read instruction sheet before you start installation and assembly.****⚠ WARNING**

- Make sure that the supporting surface will safely support the combined load of the equipment and all attached hardware and components.

**IMPORTANT! Be sure not to touch the projector while tightening the set screw on the ball and socket mount. This may cause the image to be unaligned when you let go.****IMPORTANT! Turn to the appropriate page for your ceiling installation.****Applications:**

Flush Mount ..... page 7

Extension Column ..... page 8

**Installations:**To Wood Joist Finished Ceilings,  
Exposed Wood Joists, or Wood Beam Ceilings ..... page 5

To Concrete Ceilings ..... page 6

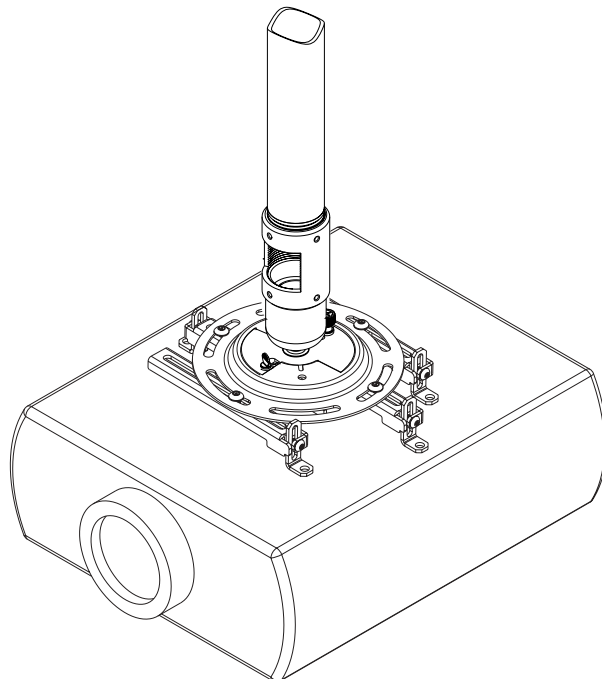

# Compatability Chart for NEC Projectors

Manufacturer	Model	Manufacturer	Model
NEC	HT410	NEC	MT1035
NEC	HT510	NEC	MT1035+
NEC	GT1150	NEC	MT830
NEC	GT2150	NEC	MT830+
NEC	GT5000	NEC	MT1040
NEC	GT6000	NEC	MT1045
NEC	GT6000R	NEC	MT840
NEC	GT2000	NEC	MT850
NEC	GT2000R	NEC	MT1050
NEC	GT950	NEC	MT1055
NEC	LT10	NEC	MT1056
NEC	LT140	NEC	MT860
NEC	LT84	NEC	MT1060
NEC	LT150	NEC	MT1060R
NEC	LT150z	NEC	MT1065
NEC	LT75	NEC	Multisync LT245
NEC	LT75z	NEC	NP1000
NEC	LT85	NEC	NP2000
NEC	LT154	NEC	V37
NEC	LT155	NEC	LT380
NEC	LT156	NEC	VT440
NEC	LT157	NEC	VT440K
NEC	LT158	NEC	VT540
NEC	LT170	NEC	VT540K
NEC	LT180	NEC	VT650
NEC	LT220	NEC	VT45
NEC	LT240	NEC	VT45K
NEC	LT240K	NEC	VT46
NEC	LT245	NEC	VT460
NEC	LT260	NEC	VT465
NEC	LT260K	NEC	V47
NEC	LT265	NEC	VT560
NEC	LT280	NEC	VT660
NEC	LT35	NEC	VT660K
NEC	HT1000	NEC	VT770
NEC	HT1100	NEC	VT47
NEC	MT1000	NEC	VT470
NEC	MT1020	NEC	VT480
NEC	MT810	NEC	VT48
NEC	MT820	NEC	VT570
NEC	MT1030	NEC	VT575
NEC	MT1030+	NEC	VT580
		NEC	VT670
		NEC	VT676
		NEC	WT600

Before you start check the parts list to insure all of the parts shown are included.

## Parts List

Description	Qty.	Part Number
A ball and socket mount	1	055-0016
B 4 mm security allen wrench	1	560-9646
C M5 x .8 x 10 mm socket pin type F screw	1	520-2031
D #10-32 x 3/8" spade thumb screw	1	560-2107
E #10-32 x 3/8" serrated washer head socket pin screw	1	520-2151
F #14 x 2.5 phillips hex head wood screw	2	5S1-015-C04
G ceiling plate	1	580-4042
H .25" ID x .56" OD x .26 spacer	2	590-2071
I extension column connector with cord management	1	580-4025
J #10-32 x 3/8" socket pin screw	2	520-2084
K #10-32 x 3/16" slotted set screw	3	520-2187
L adapter plate	1	055-0614
M M3 x 8 mm serrated washer head socket pin screw (not shown)	4	510-2004
N M4 x 10 mm serrated washer head socket pin screw (not shown)	4	510-2060
O M5 x 10 mm serrated washer head socket pin screw (not shown)	4	510-2063
P M6 x 10 mm serrated washer head socket pin screw (not shown)	4	510-2066
Q 2 mm security allen wrench	1	560-1097
R washer	4	540-2025

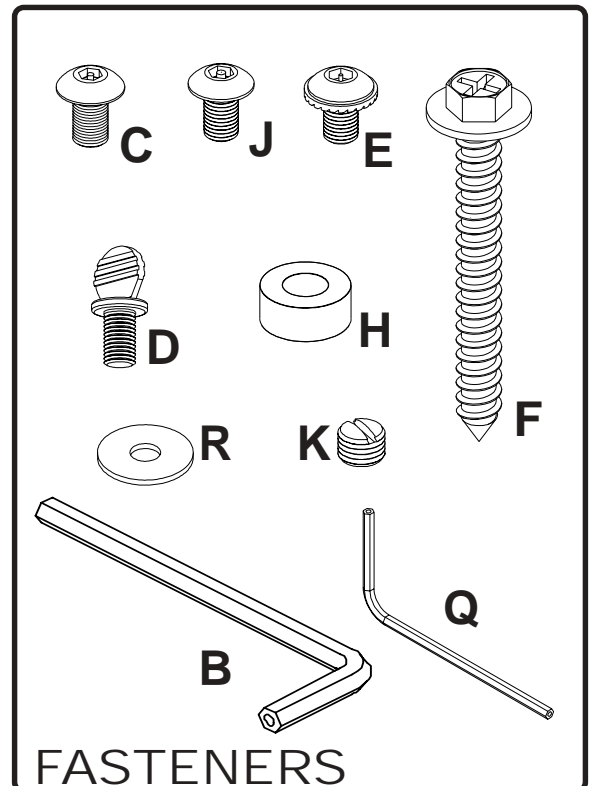
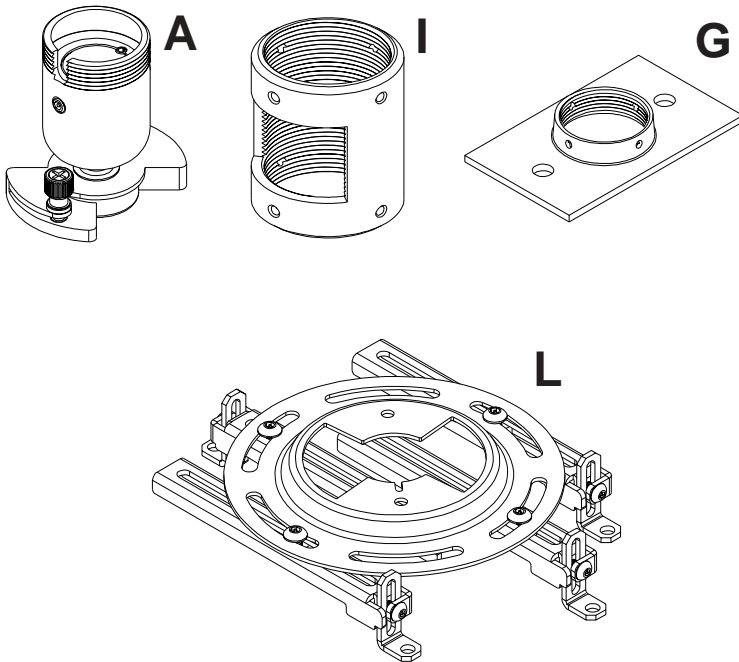

Note: Actual parts may appear slightly different than illustrated.

# Installation and assembly - Universal Adapter Plate

**Note:** The projector you are installing may differ in appearance from the sample illustrated below.

- 1 Place projector upside down. Locate adapter plate (L) with notch facing forward as close to projector center of gravity as possible without covering any mounting holes. Loosen channels, and if there are only three mounting holes remove fourth channel. Using one channel for each mounting hole, position feet of channels over mounting holes as shown below. **Important:** If projector does not have at least three mounting holes, do not use this adapter plate.

**Note:** Some projectors have feet which can be removed and the corresponding threaded insert can be used for a mounting hole.

**Note:** Once channels are in position retighten fasteners.

\*Notch indicates front of projector.

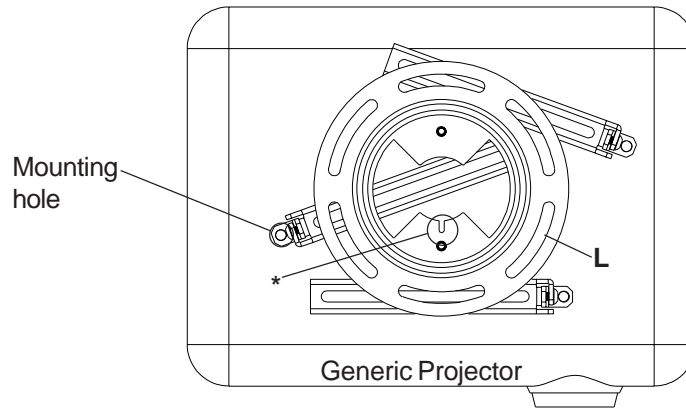

- 2 Attach adapter plate (L) to projector using one screw (M, N, O, or P) for each channel as shown below. Tighten all screws, while keeping the center of gravity. Be sure that adapter plate (L) is straight. Adjust the feet of the channels to keep the adapter plate level. Tighten all screws with 4 mm security allen wrench (B) or wrench provided with projector mount, while keeping the center of gravity. If M3 screws are used, tighten using 2 mm security allen wrench (Q).

**Note:** Projectors will require different size screws for mounting. Use a combination of screws (M, N, O, or P) and foot adjustment that will result in channels of adapter plate (L) fitting tightly against projector. **Important:** In order to properly engage the threads in the mounting holes, the screw must be turned at least 3 full turns.

Note: If using screw (M), place washer (R) between screw (M) and foot of channel.

## CAUTION

- It is the responsibility of the installer to ensure that the projector is properly ventilated. Feet of channels are used to raise the mount off the projector surface.

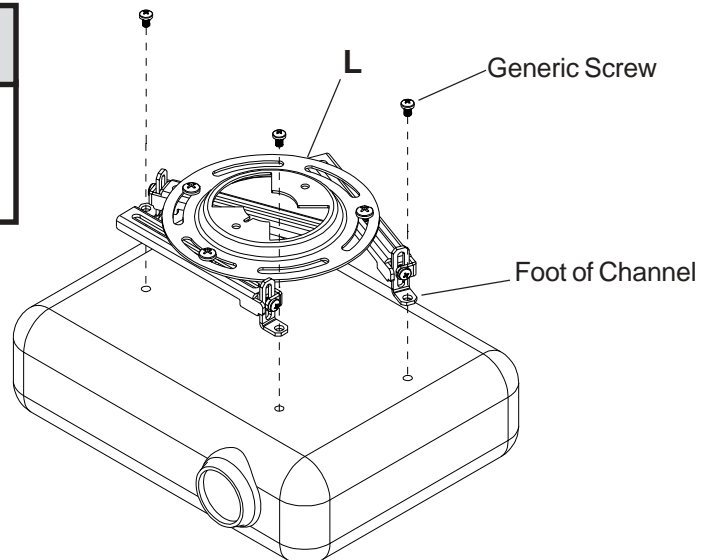

# Installation To Wood Joist Finished Ceilings, Exposed Wood Joists, or Wood Beam Ceilings

- 1 Drill two 5/32" (4 mm) dia. holes to a minimum depth of 2.5" (64 mm). Attach ceiling plate (G) with two #14 x 2.5" (6 mm x 65 mm) wood screws (F) as shown using 3/8" (10 mm) socket wrench.

Skip to step 2.

## ⚠ WARNING

- Tighten wood screws (F) so that wall plate (G) is firmly attached, but do not overtighten. Overtightening can damage the screws, greatly reducing their holding power.
- Never tighten in excess of 80 in • lb (9 N.M.).
- Make sure that mounting screws are anchored into the center of the studs. The use of an "edge to edge" stud finder is highly recommended.

## ⚠ WARNING

- It is the responsibility of the installer to verify that the supporting surface will safely support the combined load of all attached hardware and components.

**IMPORTANT: Be sure to drill holes into the joist CENTER!**

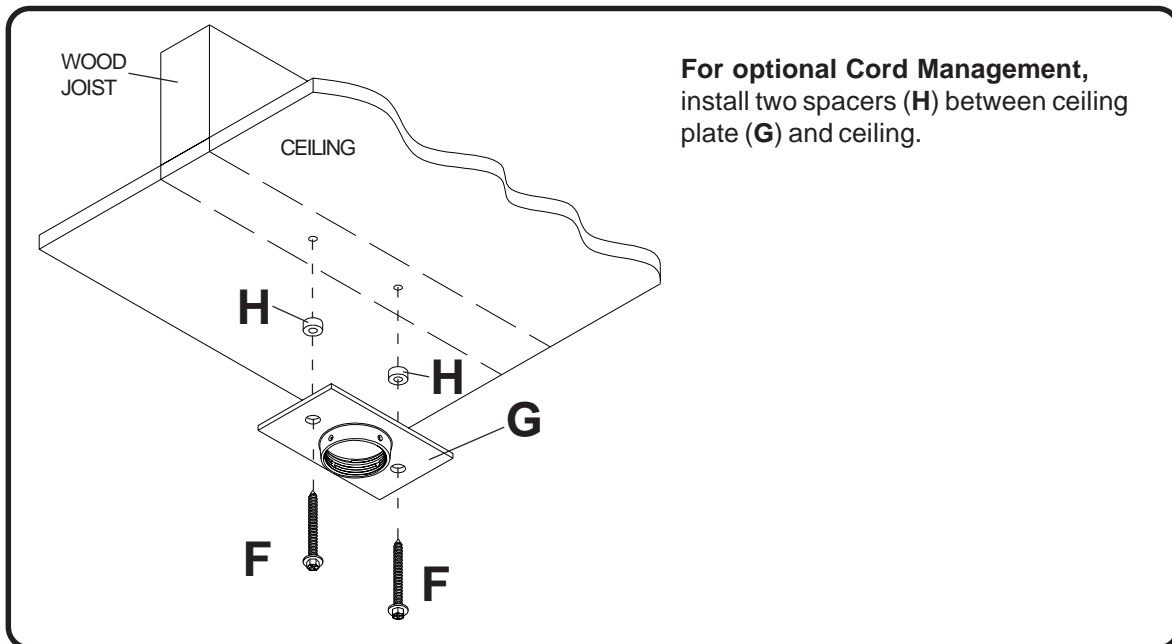
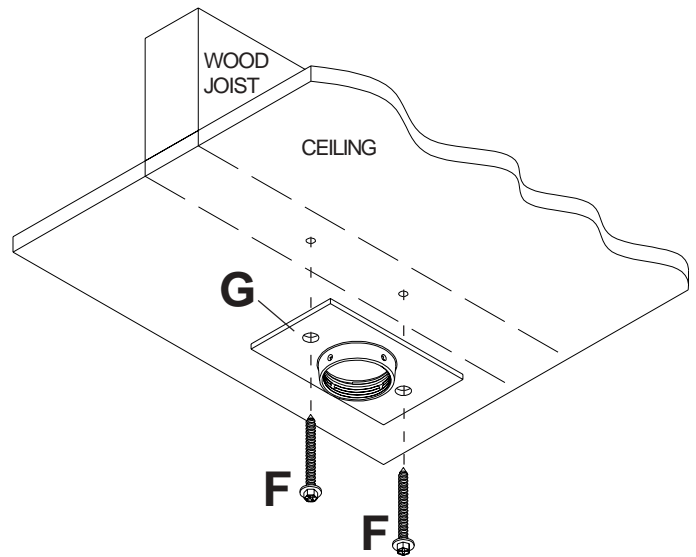

**For optional Cord Management,** install two spacers (H) between ceiling plate (G) and ceiling.

## ⚠ WARNING

- When installing wall mounts on concrete, verify that you have a minimum of 1 5/8" of actual concrete surface in the 1/4" diameter hole to be used for the concrete anchors. Do not drill into mortar joints! Concrete must meet ASTM C-90 specifications.
- Concrete must be 2000 psi density minimum. Lighter density concrete may not hold concrete anchor.
- Make sure that the supporting surface will safely support the combined load of the equipment and all attached hardware and components.
- Never exceed the Maximum Load Capacity of 50 lb (22.7 kg).

## Installation to Concrete Ceilings

ACC 203 (Alligator® concrete anchors) are recommended.

- 1** Drill two 1/4" (6 mm) dia. holes to a minimum depth of 2.5" (64 mm). Attach ceiling plate (G) using two concrete anchors and #14 x 2.5" wood screws (F) as shown in **Illustration A** and **1, 2, and 3** (below). Tighten all fasteners.

**IMPORTANT: It is the responsibility of the installer to verify that the ceiling will safely support the combined load of all attached hardware and components.**

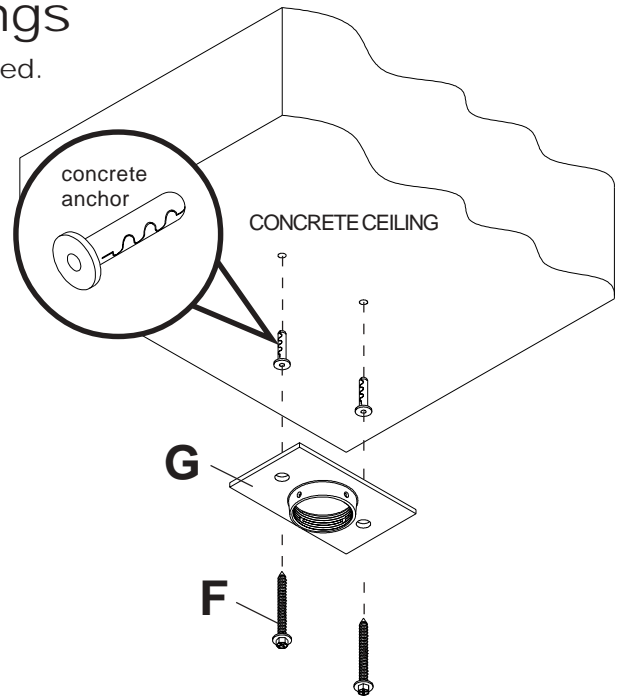
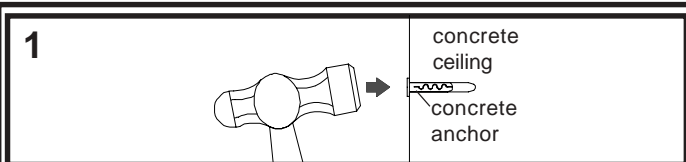

Illustration A

## ⚠ WARNING

- Tighten wood screws so that wall plate is firmly attached, but do not overtighten. Overtightening can damage the screws, greatly reducing their holding power.
- Never tighten in excess of 80 in • lb (9 N.M.).
- Make sure that mounting screws are anchored into the center of the studs. The use of an "edge to edge" stud finder is highly recommended.



Drill hole and insert anchor

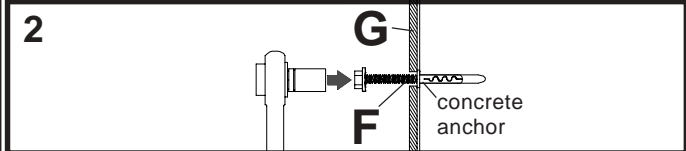

Place ceiling plate over anchor and secure with screw

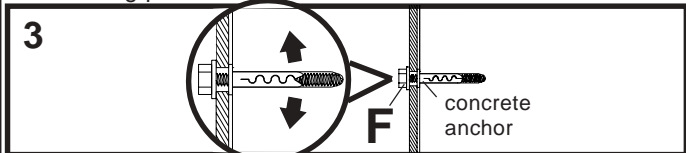

After repeating step one tighten all fasteners

## ⚠ WARNING

- **FOR DIRECT ATTACHMENT TO LOAD BEARING CONCRETE ONLY!** Concrete expansion anchors are **not** intended for attachment to concrete ceilings covered with a layer of plaster, drywall, or other finishing material. If mounting to concrete ceiling covered with plaster / drywall is unavoidable, plaster / drywall must be counterbored as shown below.

INCORRECT

CORRECT

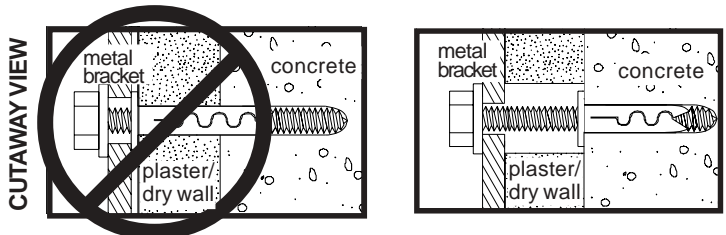

# Flush Mount Application

**2** Screw ball and socket mount (A) into ceiling plate (G). Align the notch with one of the four holes of the ceiling plate (G) and secure ball and socket mount (A) with a M5 x 10 mm socket pin screw (C) using security allen wrench (B) as shown in **detail 1**.

**Note:** Slotted set screw (K) is used to jam against the threads of the ball and socket mount to prevent any excess movement of the ball and socket mount (A). Do not overtighten screw; overtightening screw will damage threads making it difficult to separate the products.

**Skip to step 3.**

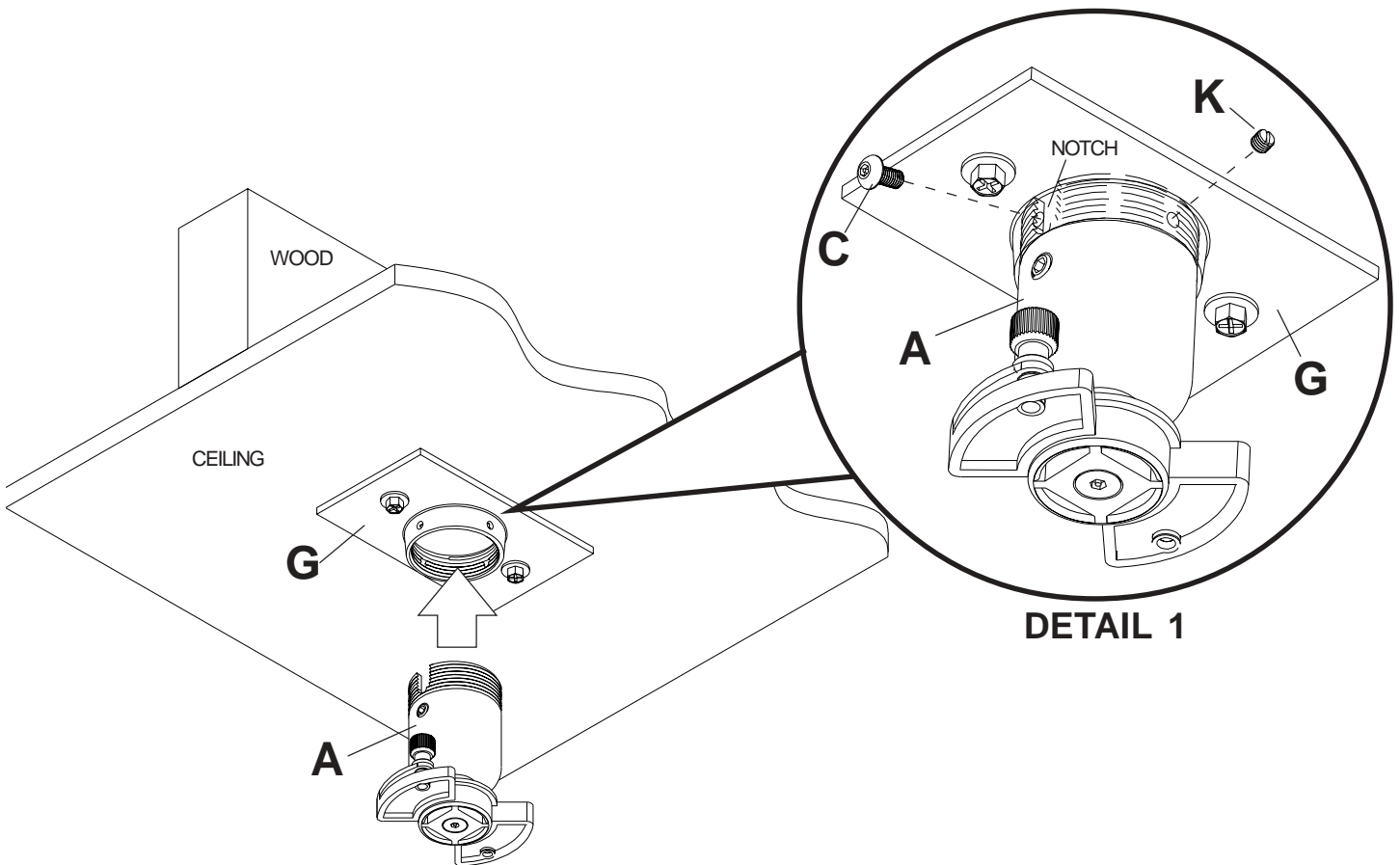

# Installation to Extension Column

**2** Screw extension column to ceiling plate (**G**). Align the notch with one of the four holes in the ceiling plate (**G**) and secure extension column with a M5 x 10 mm socket pin screw (**C**) using security allen wrench (**B**). **See detail 4.**

Screw extension column connector (**I**) to extension column. Align slot in extension column with one of the top holes in extension column connector (**I**). Insert and tighten one #10-32 x 3/8" socket pin screw (**J**) through extension column connector (**I**) into slot on extension column using security allen wrench (**B**). **See detail 5.**

Screw ball and socket mount (**A**) to extension column connector (**I**). Align slot in ball and socket mount (**A**) to one of the bottom holes in extension column connector (**I**). Insert and tighten one #10-32 x 3/8" socket pin screw (**J**) through extension column connector into slot in ball and socket mount (**A**) using security allen wrench (**B**). **See detail 6.**

**Note:** Slotted set screws (**K**) are used to jam against the threads of each connecting joint to prevent any excess movement. Do not overtighten screws; overtightening screws will damage threads making it difficult to separate the products.

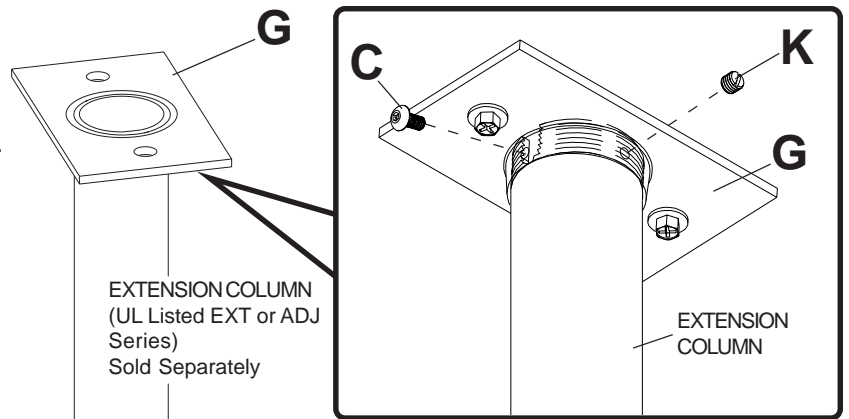

**DETAIL 4**

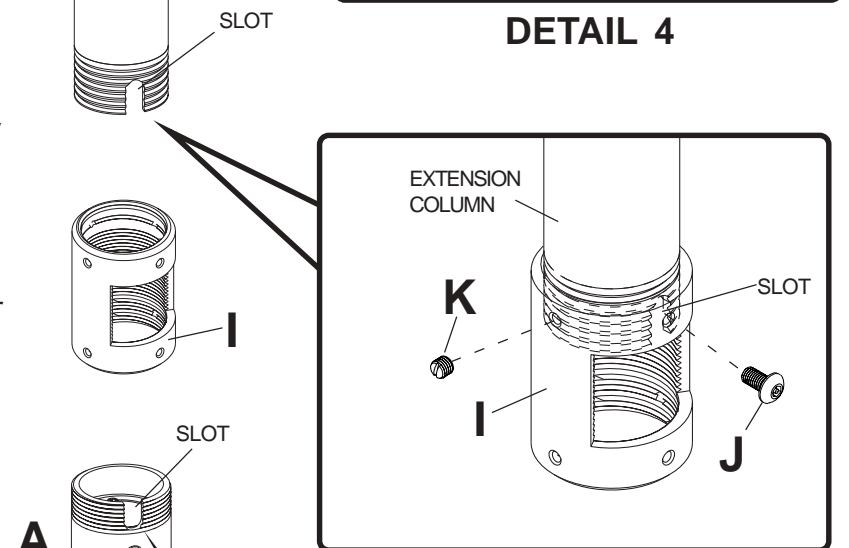

**DETAIL 5**

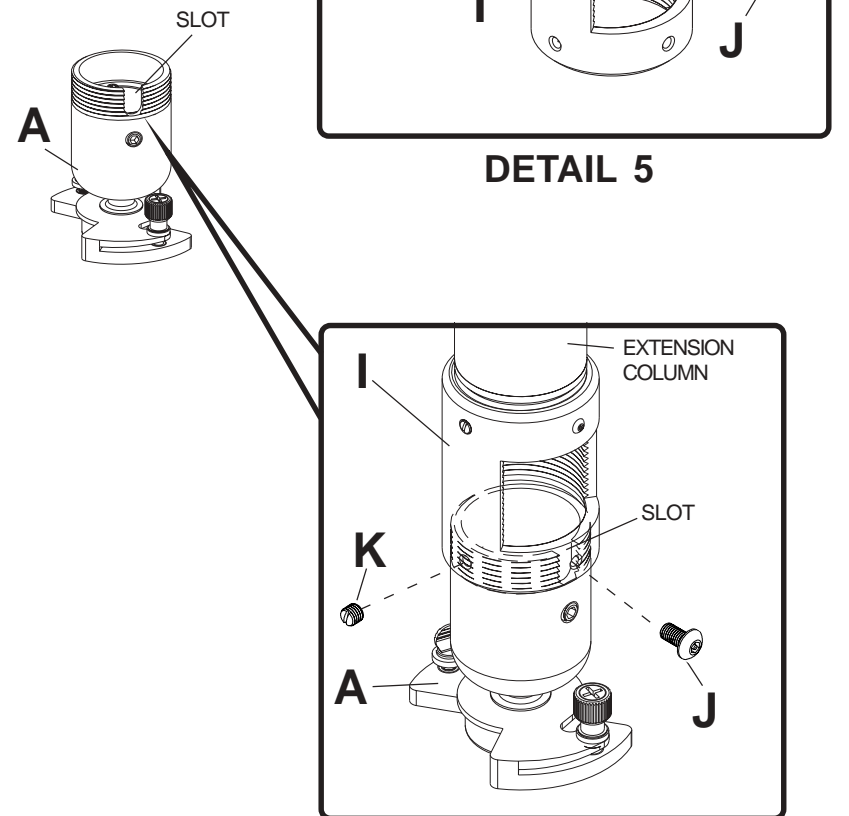

**DETAIL 6**



**Note: The projector adapter plate and projector you are installing may differ in appearance from the sample illustrated below.**

**3** Attach projector, with adapter plate already on it, to the ball and socket mount (A) by inserting the ball and socket mount (A) into the adapter plate connection and twisting until the adapter plate will no longer turn (about 75°). The spring loaded captive screw should line up with a corresponding hole on the adapter plate (this should line up automatically when the two are connected). Push down and tighten the spring loaded captive screw to secure the adapter plate to the mount. If not using the optional security feature, fasten thumb screw (D) in the hole opposite the spring loaded captive screw.

**OPTIONAL:** For security, insert serrated washer head socket pin security screw (E) in the hole opposite the spring loaded captive screw. Tighten with security allen wrench (B). This will prevent the projector from being removed.

**Note: Be sure to only use the #10-32 x 3/8" screw (E) (or the thumb screw (D)) opposite the spring loaded captive screw.**

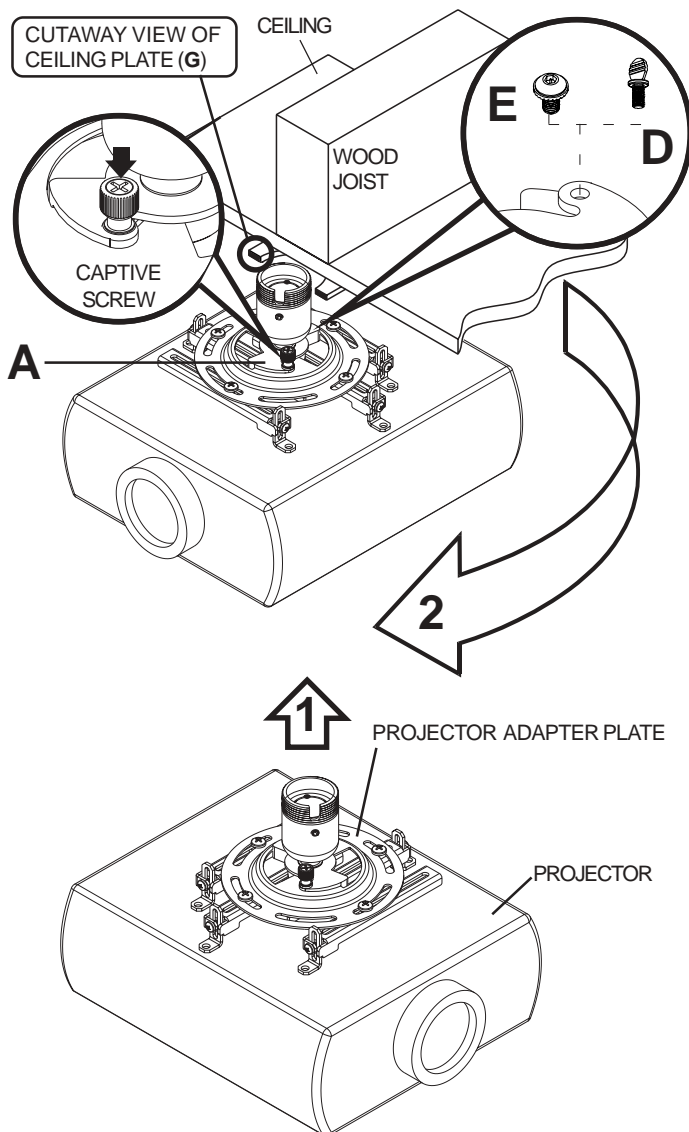

**4** To adjust roll, pitch, and yaw loosen the set screw (shown below) using security allen wrench (B) or standard 4 mm allen wrench. You should be able to just slightly loosen the screw so that your adjustments can be set without having to hold the projector. Move projector to desired position and slowly tighten set screw.

**Note: Be sure not to touch the projector while tightening the set screw. This may cause the image to be unaligned when you let go.**

**IMPORTANT: Allen wrench is your key for projector removal. Store it in a safe place.**

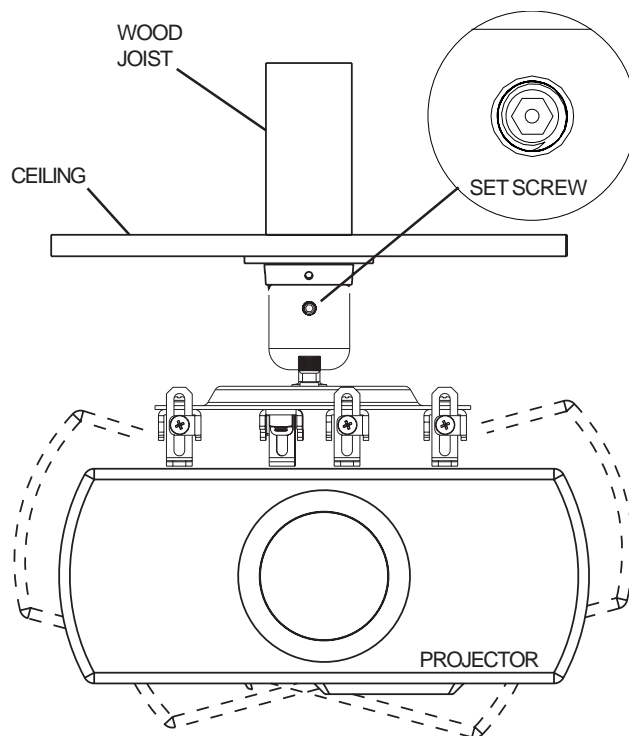

## ⚠ WARNING

- Do not lift more weight than you can handle! Use additional man power or mechanical lifting equipment to safely handle placement of the projector!