

# MS1202

## 12x2 MICRO SERIES MIC/LINE MIXER

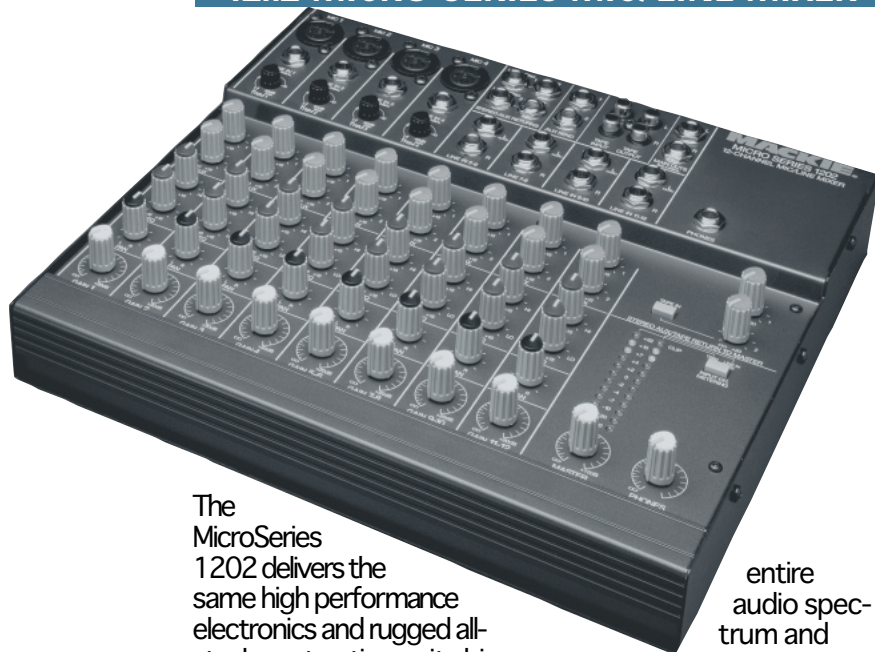

The MicroSeries 1202 delivers the same high performance electronics and rugged all-steel construction as its big brother, the CR-1604. Same high-headroom and low noise mic preamplifiers. Same overall dynamic range. Same rugged steel construction with built-in power supply, thru-hole-plated fiberglass circuit boards, gold-plated interconnects and sealed rotary controls.

The result is a rare combination of performance and reliability in a small, very affordable mixer that is well suited to serious permanent installation, video and mobile recording applications.

**Big mixer features in less than one square foot of space**

The MicroSeries 1202 mic/line mixer has:

- A working signal-to-noise ratio of 90dB, distortion below 0.009% across the

entire audio spectrum and 116dB internal dynamic range (that's 26dB better than digital!)

- Switchable phantom-powered mic inputs with discrete, balanced microphone preamps as good or better than those found in big consoles. Four conjugate-pair transistors with large-emitter geometry reduce distortion at all levels, while delivering extremely low noise (-129.5 dBm @150 ohms, 20Hz-20kHz, with over a 300K bandwidth).

- Four mono channels (each featuring discrete front-end mic preamp/line input) and four stereo input channels (each with separate left and right line inputs).

- Pan control on every channel.



### RELATED PRODUCTS

MS1202 "DUMBO EAR" RACK BRACKETS

### MORE INFORMATION

MS1202 ARCHITECTS' AND ENGINEERS' SPECIFICATIONS "IN YOUR FACE" ALL-PRODUCT BROCHURE

### FEATURES

- 4 low noise/high headroom mic inputs (-129.5 E.I.N.)
- 4 bal./unbal. line inputs
- 4 stereo line inputs
- Tape inputs/outputs
- 2 AUX sends per channel
- 2 stereo effects (AUX) returns
- Center-detent controls
- 2-band EQ
- Headphone monitor w/level control
- 3-way 12-LED peak meter display
- Rugged steel construction
- Built-in power supply
- Less than 1 square ft. "footprint"
- 3-Year Limited Warranty

# MACKIE®

# MS 1202

- Low-frequency EQ at 80Hz, high-frequency EQ at 12kHz.
- Two AUX sends per channel with up to 15dB available gain above Unity.
- A master section with stereo AUX returns, separate headphone level control and metering (also with separate left and right line inputs).
- Unity gain is easily found with the center detent

provided on all front panel gain controls.

- Three-in-one channel metering display. Normally the meters show main L/R output. But when you press the metering button, the left array displays mic preamp operating levels and the right channel shows channel operating levels. This allows you to set and meter actual levels instead of having to rely on a single overload LED.
- RCA/phono-type tape inputs and output connectors with tape input available

through AUX Return 2, via a TAPE IN switch.

- Line inputs and outputs are designed to work with any line level, from instrument level, to semi-pro -10dB, to professional +4dB levels. The main outputs operate either balanced or unbalanced, as required.
- While not specifically designed for rack mounting, “dumbo ear” rack flanges are available for the 1202, turning it into a 7-space rack mount mixer.

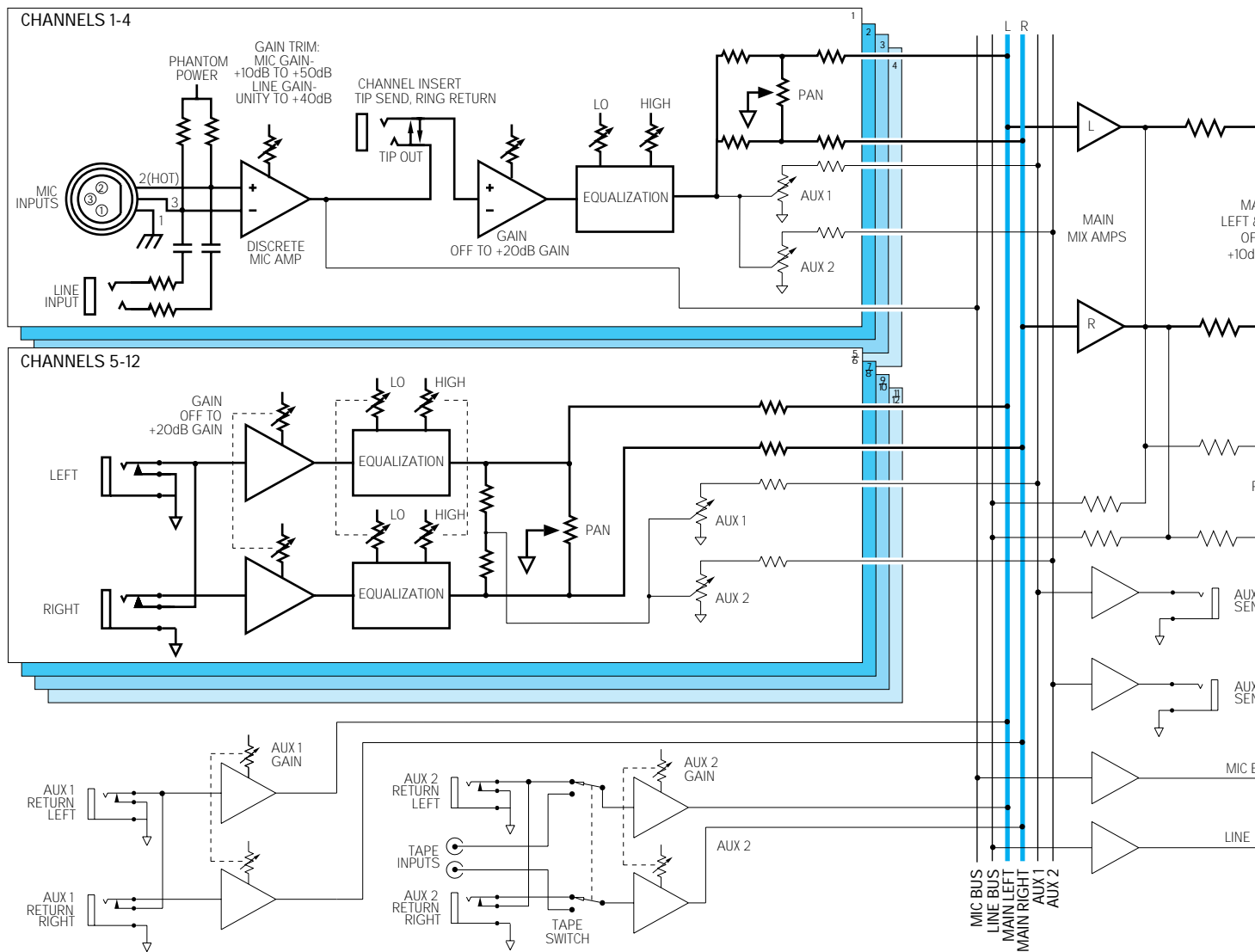

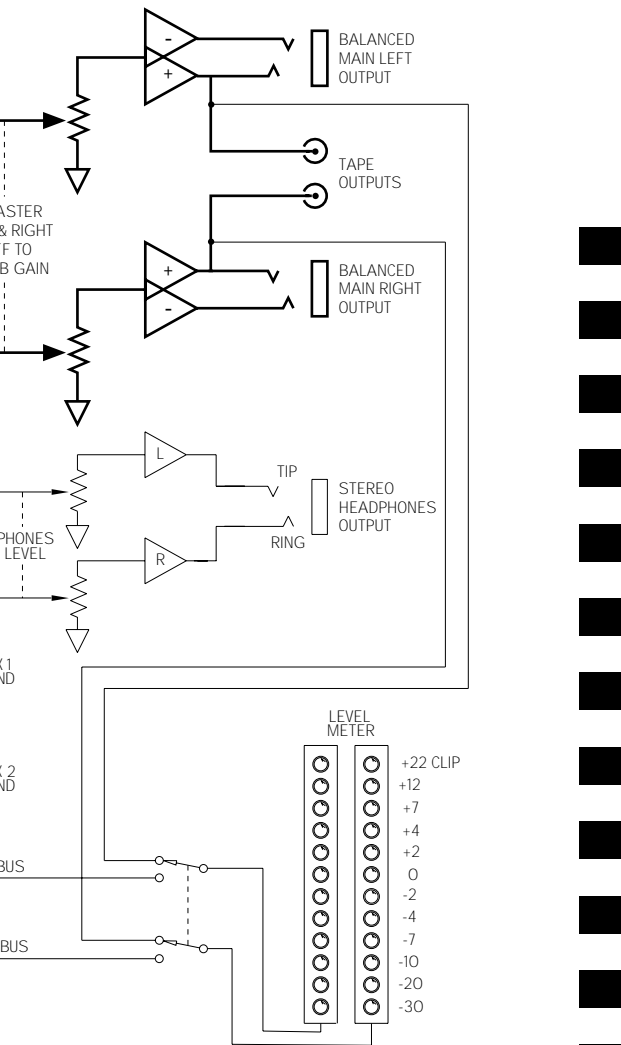
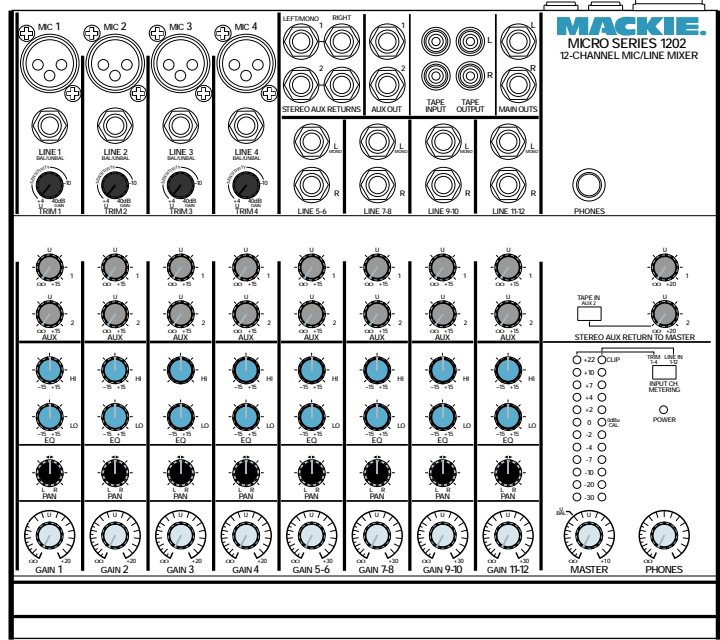

**Built like a brick.**

Like its big brother, the CR-1604, the MicroSeries 1202 has been designed by Greg Mackie, a 20-year pro audio veteran. All his designs are intended for non-stop, 24-hour-a-day professional duty in broadcast and permanent PA applications, TV and radio stations and post-editing suites where nothing must ever go wrong. The 1202 is no exception.

For example, it has sealed, co-molded rotary controls instead of open-frame phenolic potentiometers that can suffer from airborne dust and contamination. For the life of an installation, the 1202 provides minimal rotational contact noise (and if there ever is a problem, pots are individually replaceable). Plus, our combination of mounting, co-molding and energy-absorbing knob design helps prevent impact damage.

Along with its steel chassis and through-hole-plated fiberglass circuit boards, the MicroSeries 1202 also fea-

tures a built-in power supply instead of a "wall wart" or "line lump." Not only does this eliminate the inevitable hassles of dealing with external power supplies, but also actually reduces hum. The tiny transformers inside "line lumps" are typically driven into non-linearity (in excess of 15 kiloGauss) to provide enough power for the mixer. This creates stray 25- to 35µV magnetic fields that are easily picked up by shielded audio cables. The MS1202's internal transformer loafs along at under 10 kiloGauss, reducing stray fields to less than 1µV. The MS1202 also uses the same RF protection circuitry and construction as the CR-1604, making it virtually impervious to RF interference in high-energy environments.

**Multiple applications**

Frankly, the MicroSeries 1202 is so reasonably priced that it initially may be hard to take seriously. But thousands of professionals DO take the 1202 seriously enough to rely on it day-in and day-out.

We receive a steady stream of warranty cards from TV and radio stations, video production houses, touring sound companies, big-studio engineers and corporate in-house A/V departments (see examples at right).

Why? Because the MicroSeries 1202 is able to perform in applications where other small mixers don't measure up:

- Audio mixer for video post editing suites
- Impedance or level matching "tool kit"
- Headphone or cue mixer
- Effects sends submixer
- ENG mixer
- Broadcast remote mixer
- 8-track monitor mixer
- Live film and video sound mixer
- AUX inputs for a larger console

No matter what your application, you can't go wrong with a Mackie MicroSeries 1202. If you simply want the best possible mixer in the least amount of space, there can only be one choice. If cost is an issue, this is the best price-to-performance mixer available. If durability and freedom from call-backs are critical, the MS1202's construction—and track record—speak for themselves.

Only one mixer model puts so many good things into such a small package... the Mackie Designs MicroSeries 1202.

### A SAMPLING OF MS1202 OWNERS:

General Electric  
AT&T  
Southern California Edison  
Bank of America  
Ashland Oil  
Bell Labs  
Nordstrom  
IBM  
Commonwealth Edison  
GTE Airfone  
Philips Interactive Media  
Culver Video Post Prod.  
World Bible Society  
Sony  
Studer/Revox  
CBS Broadcasting  
KTIS AM/FM  
KNAX TV  
SCTV  
KTZR radio  
WBAI FM  
KNDD radio  
National Public Radio  
David Frost "On the Road"  
Cornell University  
Stanford University  
Biola University

### SPECIFICATIONS

Signal-to-Noise Ratio  
90dB ref: +4dBu (all channels assigned, panned alternately left/right)

Mic preamp equivalent input noise (E.I.N)  
-129.5dBm @ 150 ohms

Maximum gain (mic in to main out)  
84dB (to balanced out)  
78dB (to unbalanced out)

Frequency response  
20Hz to 40kHz, ±1dB

Distortion  
Less than .025% 20Hz to 20kHz

Equalization  
Low: ±1.5dB @ 80Hz  
High: ±1.5dB @ 12kHz

Maximum output level  
+28dBu balanced  
+22dBu unbalanced

Weight  
7 lbs.

Power consumption  
20 watts

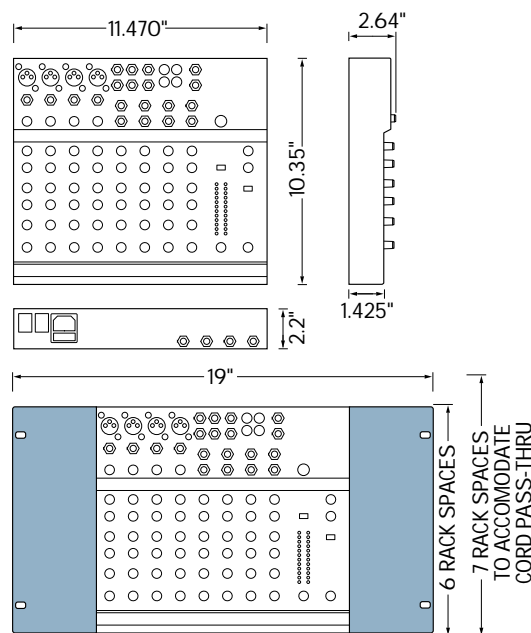

Shown with optional rack brackets

# MACKIE®

MACKIE DESIGNS INC. • 16220 WOOD-RED RD. N.E.  
WOODINVILLE • WA • USA • PHONE TOLLFREE 800/258-6883  
FAX 425/487-4337 • OUTSIDE THE U.S., PHONE 425/487-4333

Mackie Designs Inc. is engaged in a continuous program of product evaluation and improvement and reserves the right to change product specifications at any time without notice.  
©1995 Mackie Designs Inc. All rights reserved. "Mackie." is a registered trademark of Mackie Designs Inc. Printed in USA.  
12022951.2