

SINAMICS GM150 IGCT version

3



3/2	Overview
3/2	Benefits
3/2	Design
3/6	Function
3/8	Selection and ordering data
3/8	Options
	Technical data
3/14	General technical data
3/15	Control properties
3/15	Ambient conditions
3/16	Installation conditions and derating data
3/18	Converter-related technical data



SINAMICS GM150

Medium-Voltage Converters

IGCT version

Overview



SINAMICS GM150 in IGCT version

The water-cooled SINAMICS GM150 converters in IGCT version with IGCT Motor Modules are an addition to the SINAMICS GM150 converters as IGBT version in the upper power range up to 28 MVA.

SINAMICS GM150 converters in IGCT version are optimally matched to Siemens motors.

SINAMICS GM150 converters in IGCT version offer economic drive solutions that can be matched to customers' specific requirements by choosing from the wide range of available components and options.

IGCT converters are available for the following voltage and power ranges:

Rated output voltage	Type rating
3.3 kV	10 MVA to 28 MVA

Global use

SINAMICS GM150 converters in IGCT version are manufactured to international standards and regulations, making them ideally suited for global use. These converters are also available in a marine version (meeting the requirements of all major classification organizations).

Benefits

- Compact design and high flexibility in configuration ensures easy plant integration
- Easy operation and monitoring on the convenient operator panel
- Easy and reliable operation through integrated maintenance functions: the converter signals early and automatically if maintenance is required or components need to be exchanged
- High robustness and reliability due to the use of IGCT power semiconductors in the high power range and fuseless design combined with intelligent reaction to external disturbances
- Can be easily integrated into automation solutions due to PROFIBUS interface supplied as standard and various analog and digital interfaces
- High level of service-friendliness through innovative power section design with compact phase modules and easy access to all components

Design

SINAMICS GM150 converters in IGCT version are available in the basic circuit with a 12-pulse or 24-pulse Basic Line Module (option).

For higher output ratings, two or three complete converter units with isolated DC links are operated in parallel.

Phase modules in which IGCTs, diodes etc. are grouped together in one pressure stack are used in the Motor Modules.

The converter consists of cabinet units for the Basic Line Module and for the Motor Module. One of three phase modules and the control section in the Motor Module cabinet are highlighted in the illustration.

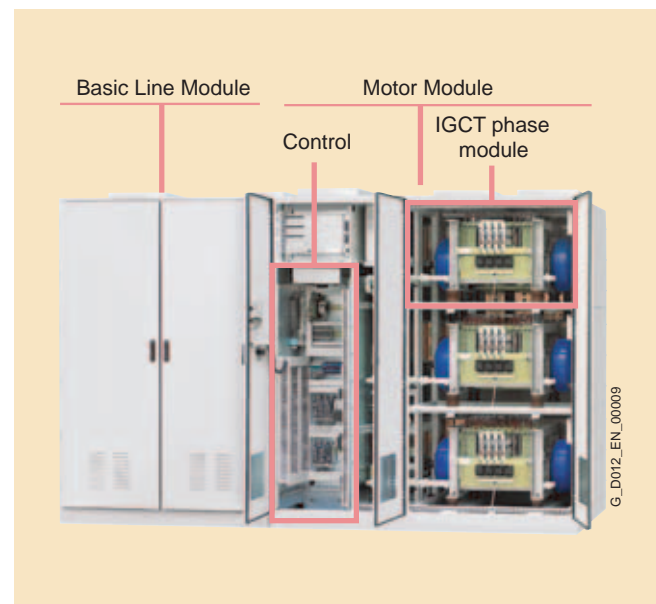

SINAMICS GM150 in IGCT version, internal arrangement (without cooling unit)

Design (continued)

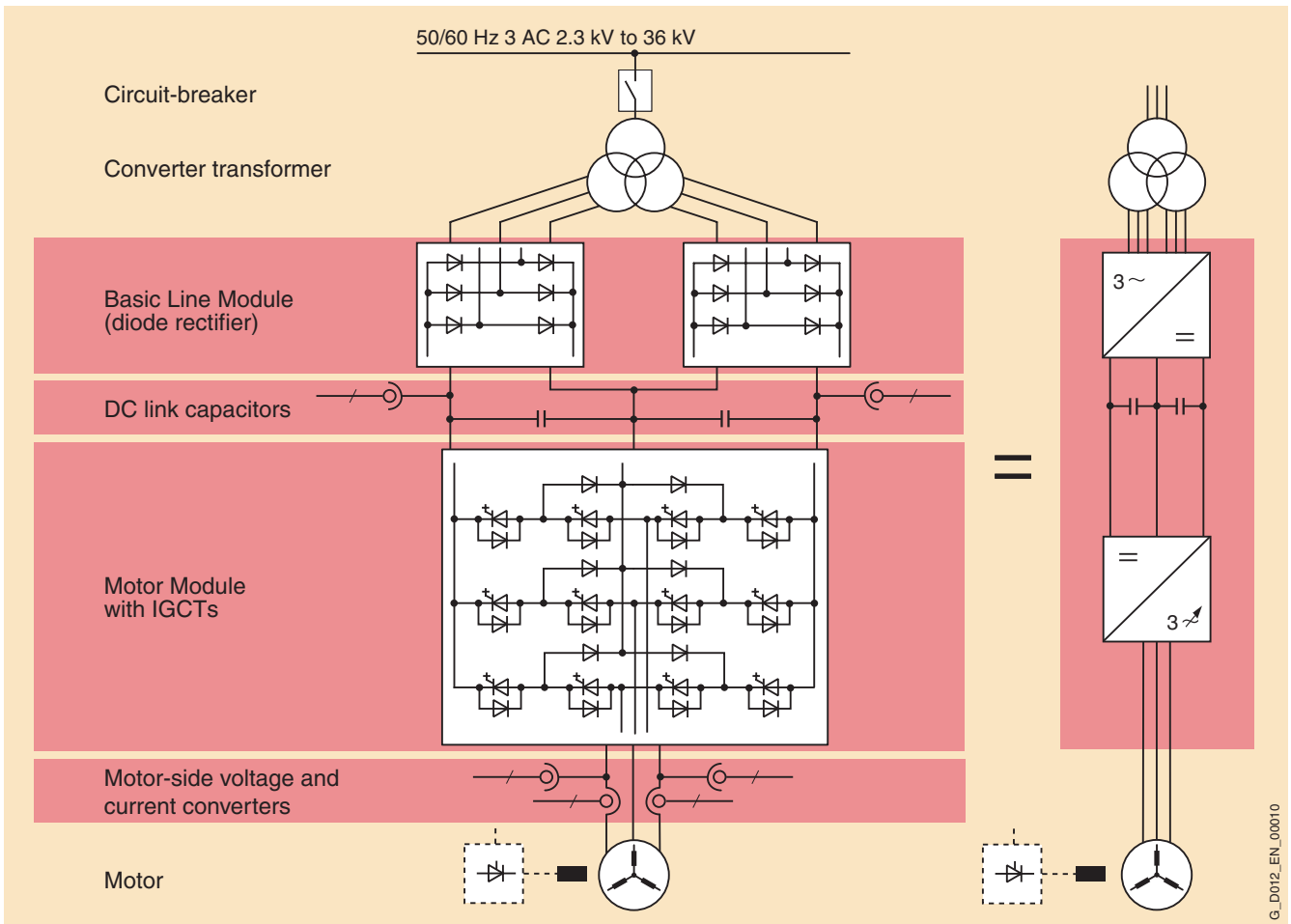

Block diagram

G_D012_EN_00010

SINAMICS GM150 Medium-Voltage Converters

IGCT version

Design (continued)

The following circuit designs are available for SINAMICS GM150 in IGCT version.

3

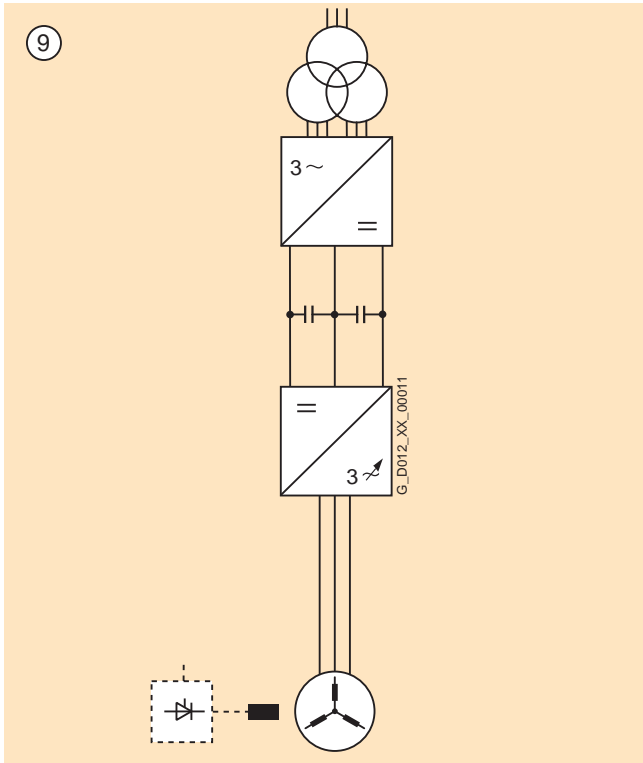

Basic circuit
12-pulse infeed

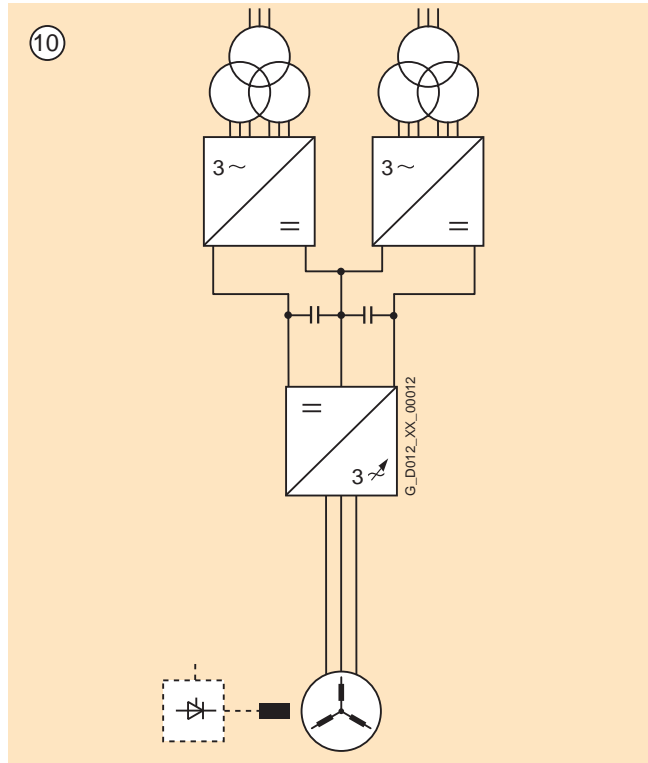

24-pulse infeed through series connection of two Basic Line Modules:
option **N15**

Design (continued)

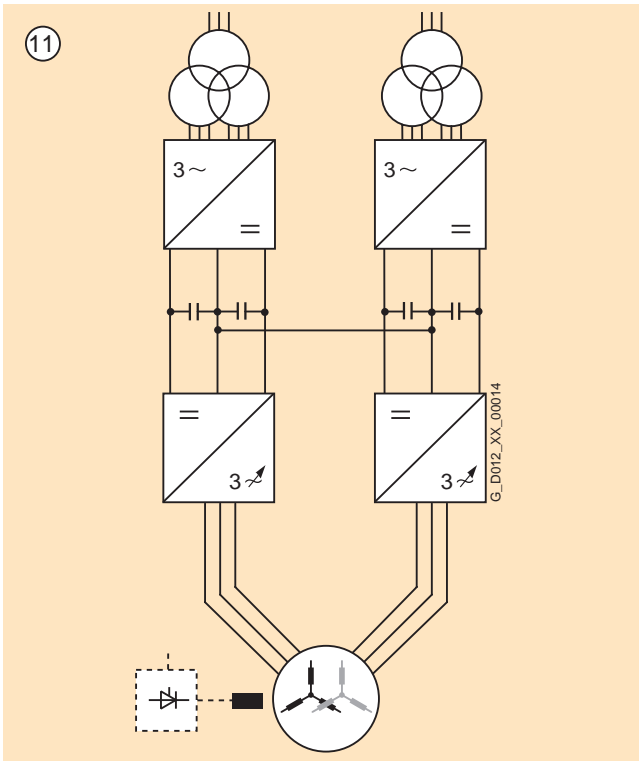

Power increased by parallel operation of two converter units ¹⁾
24-pulse infeed possible

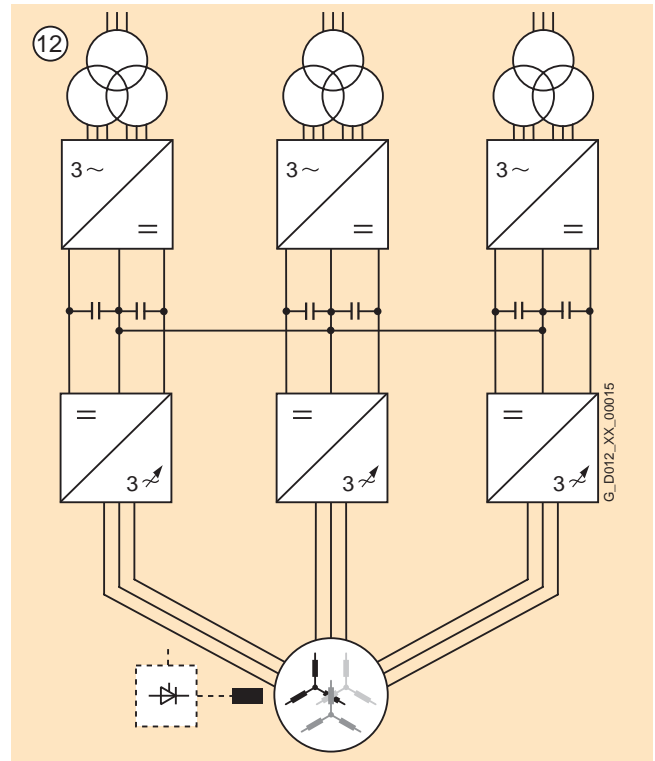

Power increased by parallel operation of three converter units ¹⁾
36-pulse infeed possible

1) Requires a motor with isolated winding systems.

SINAMICS GM150

Medium-Voltage Converters

IGCT version

Function

Characteristic features

SINAMICS GM150 in IGCT version	
Line Module (line-side rectifier)	
• Basic Line Module, 12-pulse (two-quadrant operation)	Standard
• Basic Line Module, 24-pulse (two-quadrant operation)	Option
Motor Module (motor-side inverter)	
Voltage range	3.3 kV
Power range (typ.)	10 MVA to 28 MVA
Cooling method	
• Water cooling	Standard
Control modes	
• Induction motor	Standard
• Synchronous motor, separately excited	Option
• Synchronous motor, permanently excited	Option

Software and protection functions

SINAMICS GM150 in IGCT version	Description
Closed-loop control	<p>The motor-side closed-loop control is realized as a field-oriented closed-loop vector control which can be operated as a speed or torque control as required. The closed-loop vector control achieves the dynamics of a DC drive. This is made possible by the fact that the current components forming the torque and flux can be controlled precisely and independently of each other. Prescribed torques can thus be observed and limited accurately. In the speed range from 1:10, the field-oriented closed-loop control does not require an actual speed value encoder.</p> <p>An actual speed value encoder is required in the following cases:</p> <ul style="list-style-type: none"> • High dynamics requirements • Torque control/constant torque drives with setting range > 1:10 • Very low speeds • Very high speed accuracy
Setpoint input	The setpoint can be defined internally or externally; internally as a fixed, motorized potentiometer or jog setpoint, externally via the PROFIBUS interface or an analog input of the customer's terminal block. The internal fixed setpoint and the motorized potentiometer setpoint can be switched over or adjusted using control commands via all interfaces.
Ramp-function generator	A user-friendly ramp-function generator with separately adjustable ramp-up and ramp-down times, together with adjustable rounding times in the lower and upper speed ranges, improves the control response and therefore prevents mechanical overloading of the drive train. The ramp-down ramps can be parameterized separately for emergency stop.
$V_{dc \max}$ controller	The $V_{dc \max}$ controller automatically prevents overvoltages in the DC link if the set ramp-down ramp is too short, for example. This can also extend the set ramp-down time.
Kinetic buffering (KIP)	Line voltage failures are bridged to the extent permitted by the kinetic energy of the drive train. The speed drops depending on the moment of inertia and the load torque. The current speed setpoint is resumed when the line voltage returns.
Automatic restart (option)	The automatic restart switches the drive on again when the power is restored after a power failure or a general fault, and ramps up to the current speed setpoint.
Flying restart	The flying restart function permits bumpless connection of the converter to a rotating motor.
Diagnostics functions	<ul style="list-style-type: none"> • Self-diagnostics of control hardware • Non-volatile memory for reliable diagnostics when the power supply fails • Monitoring of HV-IGBTs with individual messages for each slot • User-friendly on-site operator panel with plain text messages
Operating hours and switching cycle counter	The operating hours of the fans are detected and logged so that preventive maintenance or replacements can be performed. The switching cycles of the circuit-breaker are detected and added up, to form the basis of preventive maintenance work.
Detection of actual motor speed (option)	The SMC30 Sensor Module Cabinet-Mounted can be used to detect the actual motor speed. The signals from the rotary pulse encoder are converted here and made available for evaluation via the DRIVE-CLiQ interface of the controller.
Operator protection	The cabinet doors of the power sections are fitted with electromagnetic locks. This prevents the cabinet doors from being opened while hazardous voltages are present inside the cabinet.

Function (continued)

Software and protection functions

SINAMICS GM150 in IGCT version	Description
EMERGENCY STOP button	The converters are equipped as standard with an EMERGENCY STOP button with protective collar which is fitted in the cabinet door. The contacts of the pushbutton are connected in parallel to the terminal block so they can be integrated in a protection concept on the plant side. EMERGENCY STOP category 0 is set as standard for an uncontrolled shutdown (DIN EN 60204-1/VDE 0113-1 (IEC 60204-1)). The function includes voltage disconnection of the converter output through the circuit-breaker. Consequently the motor coasts down. EMERGENCY STOP category 1 is optionally available for a controlled shutdown.
Insulation monitoring	The converters feature insulation monitoring of the whole galvanic network from the secondary side of the transformer to the stator windings of the motor.
I/O monitoring	An extensive package of options for I/O monitoring (from the transformer and the motor through to the auxiliaries) is available. In addition it is possible to monitor the temperature with thermocouples or PT100 resistors.
Thermal overload protection	A warning message is issued first when the overtemperature threshold responds. If the temperature rises further, either a shutdown is carried out or automatic influencing of the output current so that a reduction in the thermal load is achieved. Following elimination of the cause of the fault (e.g. improvement of the ventilation), the original operating values are automatically resumed. In the case of water-cooled converters, the water temperature and flow rate are detected at several points in the cooling circuit and evaluated. An extensive self-diagnostics protects the converter and reports faults.
Grounding switch (option)	If grounding on the line or motor side is required for safety and protection reasons, a motor-operated grounding switch can be ordered. For safety reasons, the converter controller locks these grounding switches against activation while voltage is still present. The control is integrated into the protection and monitoring chain of the converter. The grounding switches are inserted automatically when the standard grounding switches of the DC link are inserted.

AOP30 operator panel



The AOP30 operator panel is fitted into the cabinet door of the SINAMICS GM150 for operation, monitoring and commissioning.

It has the following features and characteristics:

- graphical LCD display with backlighting for plain-text display and a bar display of process variables
- LEDs for displaying the operational status
- help function describing causes of and remedies for faults and alarms
- keypad for operational control of a drive
- local/remote switchover for selecting the input point (priority assigned to operator panel or customer's terminal block/PROFIBUS)
- numeric keypad for input of setpoint or parameter values
- function keys for prompted navigation in the menu
- two-stage safety strategy to protect against accidental or unauthorized changes to settings. Operation of the drive from the operator panel can be disabled by a password, ensuring that only parameter values and process variables can be displayed in the panel. A password can be used to prevent the unauthorized modification of converter parameters.

The operator panel languages - English, German, Spanish and Chinese - are stored on the CompactFlash card of the Control Unit.